

TRANSDRIVE[®]

DRIVE PERFORMANCE



Belt & Chain Tensioners

TRANSDRIVE®

DRIVE PERFORMANCE

TransDrive was established to bring together our passion and experience in power transmission by being able to offer affordable, high-quality products to the power transmission and bearing market. Built on the philosophy of improving performance and quality of all of our TransDrive products.

Transdrive products have been manufactured and tested to meet ISO standards and the tough, working conditions of heavy industries.

Our team have experience in power transmission and bearings. Every product we design and manufacture is backed by years of industry knowledge and an understanding of what our customers and the market need.

At TransDrive, our goal is simple: to provide accessible, high-quality products at affordable pricing. With an unwavering commitment to excellence, TransDrive operates with a focus on providing innovative industry solutions.

Whether it is through our custom products, the standard range of pulleys, slew drives, chains and sprockets, TransDrive is dedicated to delivering effective solutions for the trades that offer increased productivity and reliability.

TransDrive exclusively supply to Resellers, Wholesalers, and Original Equipment Manufacturers (OEMs) only.

Distributors

Western Australia

Chain & Drives, Wangara
Unit 1, 45 Inspiration Drive,
Wangara, WA 6065 Australia

P +61 8 9303 4966

E support@chainanddrives.com.au

Chain & Drives, Welshpool
Unit 16, 51-53 Kewdale Road,
Welshpool, WA 6106 Australia

P +61 8 6314 1155

E support@chainanddrives.com.au

New South Wales

Chain & Drives, Arndell Park
Unit 7, 70 Holbeche Road,
Arndell Park, NSW 2148 Australia

P +61 2 9674 8611

E salesnsw@chainanddrives.com.au

Tank Enviro Systems
Unit 6, 68 Railway Crescent,
Lisarow, NSW 2250

P +61 2 4328 1066

E tankadmin@tankenviro.com.au

Queensland

Chain & Drives, Rocklea
Unit 3, 55 Collinsvale Street,
Rocklea, QLD 4106 Australia

P +61 7 3059 9188

E salesqld@chainanddrives.com.au

Become a TransDrive Dealer

Interested in becoming a TransDrive Dealer?

Get in touch:

E info@transdrive.com.au

Contents

Chain Tensioners	04
Type S with SC Sliding Block	05
Type S with Roller	06
Type S with Sprocket	07
Type L with AR Sliding Block	08
Type L with SC Sliding Block	09
Tensioner Arm	10
SE Chain & Belt (Rosta Style) Tensioner Arm	11
Block Tensioner Arm - OVR Sliding	13
Block Tensioner Arm - SB Bracket	14
Block Tensioner Arm - SE Idler Sprocket	15
Block Tensioner Arm - SE Belt Roller	16
Block Tensioner Arm - SP (Z-A-B) Pulley	17

Chain Tensioners

Chain tensioners are precision mechanical devices used to maintain consistent tension in industrial chain drive systems. They automatically adjust chain slack, reducing wear, minimising noise, and improving overall power transmission efficiency across various mechanical applications like conveyors, manufacturing equipment, and industrial machinery.



Type S with SC Sliding Block

The Type S with sliding block chain tensioner is an industrial chain tensioning device designed for heavy-duty applications. It features a semi-circular (SC) profile sliding block made from high-density polyethylene (HD 1000, green), which provides low friction and long wear life. The main body and column are constructed from PA6 polyamide reinforced with 30% fibreglass, ensuring strength and durability. All other components, such as the spring and fixings, are made from stainless steel (INOX 304L), offering corrosion resistance.

This tensioner is widely used in conveyor and power transmission systems to maintain optimal chain tension, reduce vibration, and extend chain life

Features

- ▶ Available in heavy (high voltage, 100–240 N) or light (low voltage, 60–140 N) spring tension versions.
- ▶ Suitable for simplex, duplex, and triplex chains, with a 40 mm tensioning stroke.
- ▶ Interchangeable with common industry tensioner sizes and compatible with a wide range of chain sizes (04B to 24B).
- ▶ The SC (semi-circular) sliding block style is ideal for chain angles up to 90°, providing smooth and reliable chain guidance

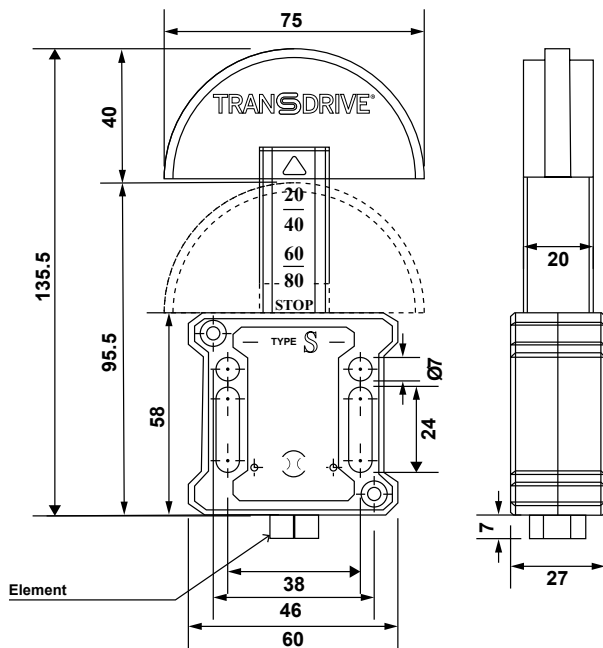

All measurements in mm.

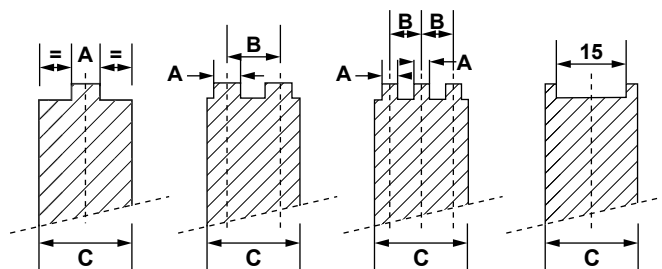

Every effort has been taken to ensure that the data listed in this catalogue is correct. Transdrive will not accept liability for any damage or loss caused as a result of the data in this catalogue.

Simplex Chain				
Part No.	Chain	A	B	C
S06B1H	06 B1	5	-	20
S06B1UH	06 B1	15	-	20
S08B1H	08 B1	7	-	20
S10B1H	10 B1	9	-	20
S12B1H	12 B1	11	-	20

Duplex Chain				
Part No.	Chain	A	B	C
S06B2H	06 B2	5	10.24	20
S08B2H	08 B2	7	13.92	20
S10B2H	10 B2	9	19.59	20
S12B1H	12 B1	11	-	20

Triplex Chain				
Part No.	Chain	A	B	C
S06B3H	06 B3	5	10.24	30
S08B3H	08 B3	7	13.92	35

All measurements in mm.

Size	Stroke (m/m)				
	40	30	20	10	0
L	60	80	100	120	140
H	100	140	170	200	240

All measurements of Force measured in Newtons.

Type S with Roller

The Type S with Roller is a heavy-duty industrial chain tensioner designed for use with a polyamide (nylon) roller instead of a sliding block. This configuration is ideal for applications requiring low friction and high-speed operation, as the roller minimizes resistance and wear on the chain.

This tensioner is suitable for conveyor and power transmission systems where smooth, reliable chain guidance at high speeds is required

Features

- ▶ Polyamide roller with an outside diameter of 40 mm, suitable for high-speed applications up to 8,000 rpm.
- ▶ Heavy tension as standard, with an optional light tension version available.
- ▶ Main body and column constructed from reinforced polyamide for strength and durability.
- ▶ Compatible with various chain sizes and configurations (simplex, duplex, triplex).
- ▶ Provides consistent chain tension, reduces vibration, and extends chain and sprocket life.

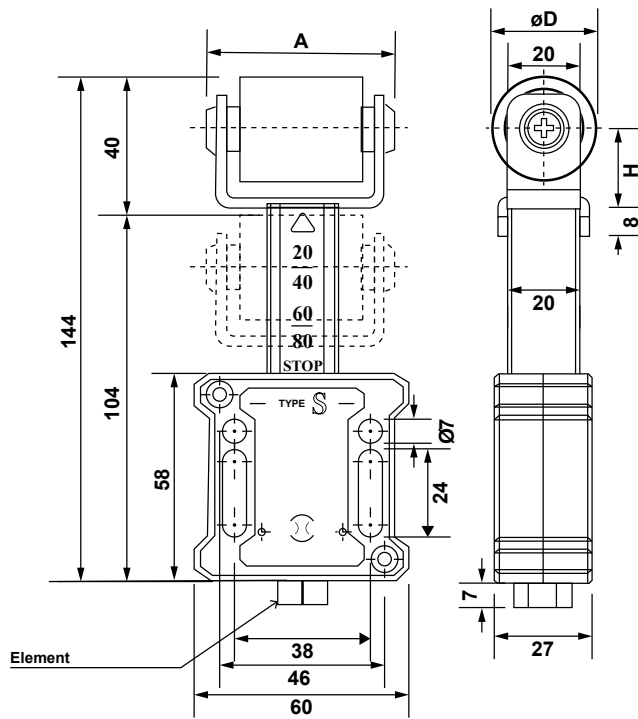

All measurements are in mm.

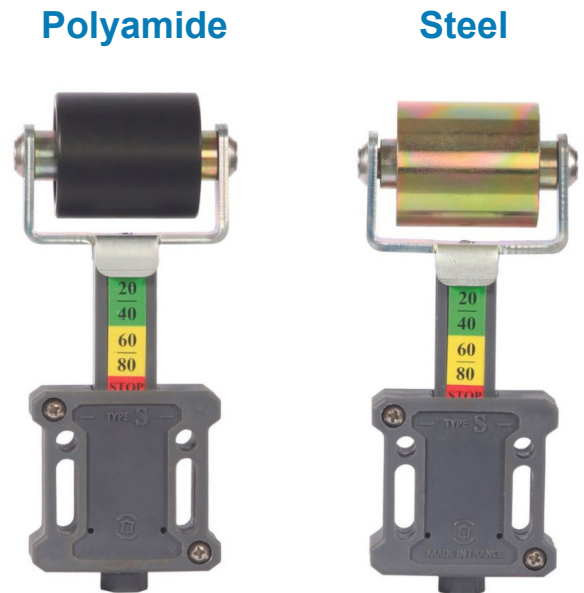

Size	Stroke (m/m)				
	40	30	20	10	0
L	60	80	100	120	140
H	100	140	170	200	240

All measurements of Force measured in Newtons

Polyamide	Steel (Zinc Plated Steel Roller)	Stainless Steel (Roller & Bearing)	Polyamide- Stainless Steel	Max SPEED T/mm	A	B	C	OD	H
Galvanized Steel + Polyamide Roller	Galvanized Steel Yoke + Galvanized Steel Roller	Stainless steel clevis + Stainless steel roller + Stainless steel bearing	Chape Inox + Galet Polyamide + Roulement Inox						
RE-2H	ETRU-2H	ETXRU-2H	ETXRE-2H	8000	54	35	45	30	22.5
RE-3/4H	ETRU-3/4H	ETXRU-3/4H	ETXRE-3/4H	8000	70	45	58	40	27.5

All measurements in mm.

Type S with Sprocket

The Type S with Sprocket is a robust industrial chain tensioner designed for heavy-duty applications where chain guidance via a steel sprocket is preferred over sliding blocks or rollers. This tensioner uses a zinc-plated steel sprocket mounted on an enlarged bearing, ensuring smooth rotation and durability. The sprocket is available in various sizes to suit different British Standard simplex and duplex chains (e.g., 06B1, 06B2, 08B1, 08B2), with dimensions tailored to match chain pitch and width.

This configuration is ideal for applications where minimal chain wear and precise alignment are critical, such as conveyors and power transmission systems

Features

- ▶ Heavy tension as standard, with an optional light tension version available.
- ▶ Sprocket ensures precise and low-friction chain guidance, ideal for higher tension and speeds up to 60 m/min.
- ▶ Main body and arm constructed from high-strength materials for industrial reliability.
- ▶ Fully compatible with a wide range of chain sizes and configurations.
- ▶ Easy installation and interchangeable with other common tensioner types.

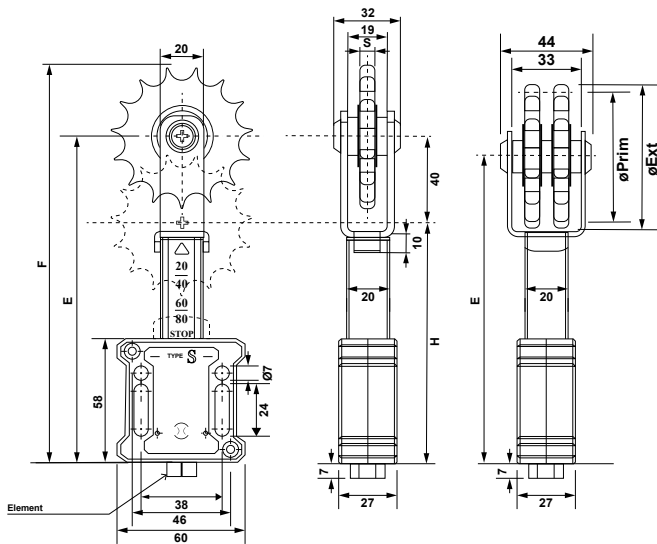

All measurements are in mm.

Simplex

Duplex



Steel

Stainless Steel

Size	Stroke (m/m)				
	40	30	20	10	0
L	60	80	100	120	140
H	100	140	170	200	240

All measurements of Force measured in Newtons.

Steel	Stainless Steel	Z	Chain		S	OD	PCD	F	E	H
			mm	BS						
RX-06B1H	RXI-06B1H	15	9.525	06 B1	5.3	49.3	45.81	160	135	95
RX-06B2H	RXI-06B2H	15	9.525	06 B2	5.3	49.3	45.81	168	143.5	103.5
RX-08B1H	RXI-08B1H	15	12.7	08 B1	7.2	65.5	61.09	186	153.5	113.5
RX-08B2H	RXI-08B2H	15	12.7	08 B2	7.2	65.5	61.09	176	143.5	103.5
RX-10B1H	RXI-10B1H	15	15.8	10 B1	9.1	83	76.36	195	153.5	113.5

All measurements in mm.

Type L with AR Sliding Block

The Type L with AR sliding block is a heavy-duty chain tensioner designed for industrial chain drive systems. It features an "AR" (arc profile) sliding block, providing smooth, low-friction chain guidance and effective tensioning across simplex, duplex, and triplex chains. The AR sliding block is ideal for applications requiring robust tensioning over longer contact distances.

This tensioner is commonly used in conveyor and power transmission applications where reliable, long-life chain tensioning is essential

Features

- ▶ Arc profile (AR) sliding block for extended chain contact and reduced wear.
- ▶ Suitable for simplex, duplex, and triplex chains in a wide range of sizes
- ▶ Heavy tension as standard, with optional light tension available.
- ▶ Main body and column constructed from reinforced polyamide for strength and durability.
- ▶ Provides consistent tension, reduces vibration, and extends chain and sprocket life.



Simplex Chain				
Part No.	Chain	A	B	C
L-AR06B1H	06 B1	5	-	30
L-AR08B1H	08 B1	7	-	30
L-AR10B1H	10 B1	9	-	30
L-AR12B1H	12 B1	11	-	30
L-AR16B1H	16 B1	16	-	30
L-AR20B1H	20 B1	18	-	30

Duplex Chain				
Part No.	Chain	A	B	C
L-AR06B2H	06 B2	5	10.24	30
L-AR08B2H	08 B2	7	13.92	30
L-AR10B2H	10 B2	9	16.59	30
L-AR12B2H	12 B2	11	19.46	35
L-AR16B2H	16 B2	16	31.88	50

Triplex Chain				
Part No.	Chain	A	B	C
L-AR06B3H	06 B3	5	10.24	30
L-AR08B3H	08 B3	7	13.92	35

All measurements are in mm.

Type	Stroke (m/m)				
	40	30	20	10	0
1 Spring (L) Light Tension	60	80	100	120	140
1 Spring (H) Heavy Tension	100	140	170	200	240
2 Spring (L) Light Tension	120	160	200	240	280
2 Spring (H) Heavy Tension	200	270	340	400	480
3 Spring (L) Light Tension	180	240	300	360	420
3 Spring (H) Heavy Tension	300	420	500	600	720

All measurements of Force measured in Newtons.

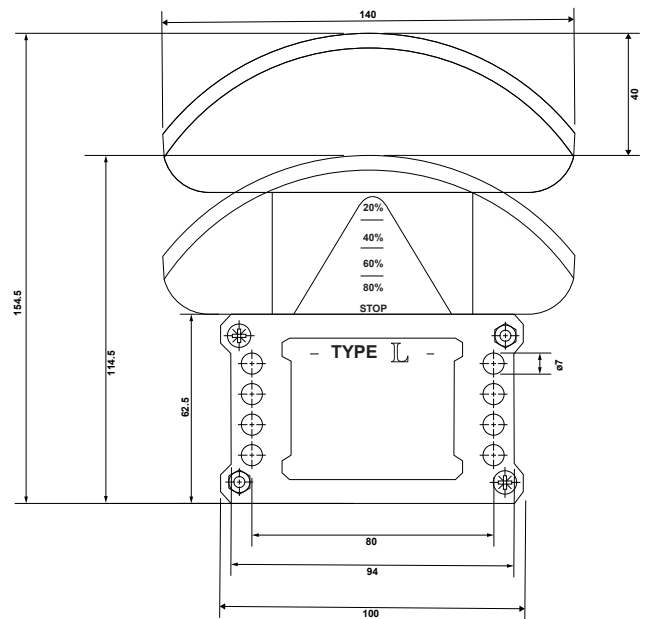
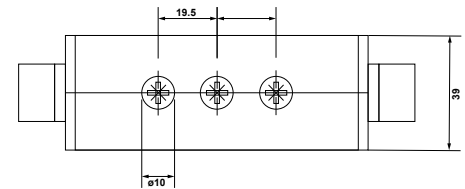

All measurements are in mm

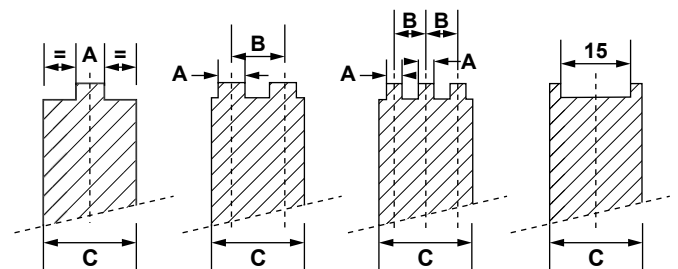

Type L with SC Sliding Block

The Type L with SC (semi-circular) sliding block is a robust industrial chain tensioner designed for heavy-duty chain drive systems. It features a semi-circular profile sliding block, machined from green polyethylene HD 1000, which provides low friction and long wear life for effective chain guidance and tensioning.

This tensioner is commonly used in conveyor and power transmission applications requiring consistent, durable, and low-maintenance chain tensioning. It is interchangeable with industry-standard tensioners and suitable for various chain sizes and configurations

Features

- ▶ Semi-circular (SC) sliding block profile, ideal for maintaining chain alignment and tension over angles up to 90°.
- ▶ Main case constructed from PA6 polyamide reinforced with 30% glass fibre for high strength, with the column in black polyethylene HD 500.
- ▶ Compatible with a wide range of British Standard simplex, duplex, and triplex chains.
- ▶ Heavy tension as standard, with an optional light tension version available.
- ▶ Provides a 40 mm tensioning stroke for reliable chain engagement.
- ▶ Reduces vibration, minimizes chain wear, and extends the service life of both chain and sprockets.

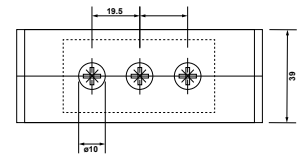

Simplex Chain				
Part No.	Chain	A	B	C
L-SC06B1H	06 B1	5	-	30
L-SC08B1H	08 B1	7	-	30
L-SC10B1H	10 B1	9	-	30
L-SC12B1H	12 B1	11	-	30
L-SC16B1H	16 B1	16	-	30
L-SC20B1H	20 B1	18	-	30

Duplex Chain				
Part No.	Chain	A	B	C
L-SC06B2H	06 B2	5	10.24	30
L-SC08B2H	08 B2	7	13.92	30
L-SC10B2H	10 B2	9	16.59	30
L-SC12B2H	12 B2	11	19.46	35

Triplex Chain				
Part No.	Chain	A	B	C
L-SC06B3H	06 B3	5	10.24	30
L-SC08B3H	08 B3	7	13.92	35

All measurements are in mm.

Type	Stroke (m/m)				
	40	30	20	10	0
1 Spring (L) Light Tension	60	80	100	120	140
1 Spring (H) Heavy Tension	100	140	170	200	240
2 Spring (L) Light Tension	120	160	200	240	280
2 Spring (H) Heavy Tension	200	270	340	400	480
3 Spring (L) Light Tension	180	240	300	360	420
3 Spring (H) Heavy Tension	300	420	500	600	720

All measurements of Force measured in Newtons.

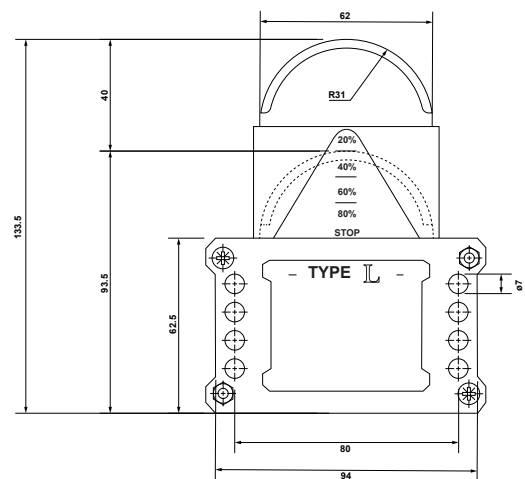

All measurements are in mm

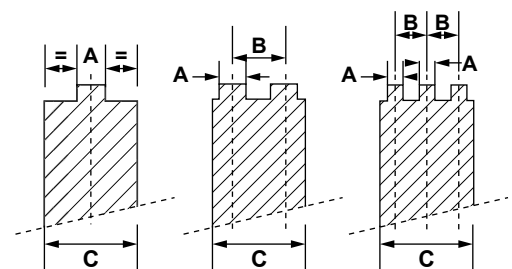

Tensioner Arm

The Elastomeric Tensioners utilise a reliable and well-established design to maintain consistent and uniform tension in both chain and belt drives, effectively compensating for chain and belt stretch.

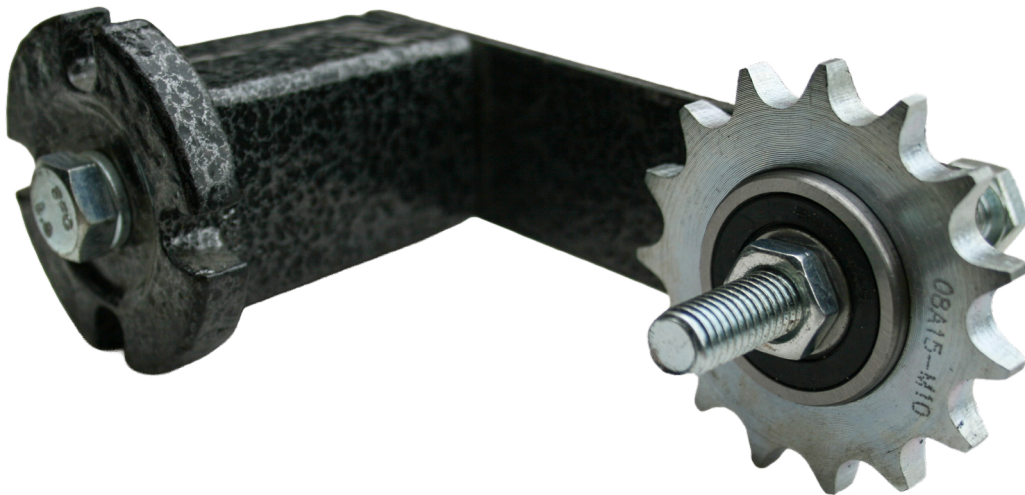

SE Chain & Belt (Rosta Style) Tensioner Arm

Proven to be an effective way for tensioning chain and belt drives in most applications, the TransDrive Rubber Block Series Tensioner has been designed to ensure optimal performance and longevity with reduced maintenance issues. From conveyor systems to automotive engines, the Rubber Block Series Tensioners deliver consistent force, minimizing belt slippage and maximising efficiency.

Features

- ▶ A one nut mounting system, which allows for 360° rotation.
- ▶ Can be pre-tensioned by up to 30°, this means that as the chain or belt stretches, the tensioner automatically takes up the slack as the elastomeric elements automatically adjust the drives tension.
- ▶ Chain and Belt life is increased by as much as 30%.
- ▶ Elastomeric parts absorb vibrations and shock loading.
- ▶ Maintenance Free – no metal on metal parts, lubrication free.
- ▶ Impervious to dust and dirt
- ▶ Operating temperature -40°C to +80°C.
- ▶ Two holes are provided on the arm, allowing two different levels of force to be generated: “normal” and “hard”. The “hard” setting deploys approximately 25% more force.



Materials

- ▶ Stainless Steel
- ▶ Galvanized
- ▶ Nickel Plated
- ▶ Plastic



SE Chain & Belt (Rosta Style) Tensioner Arm

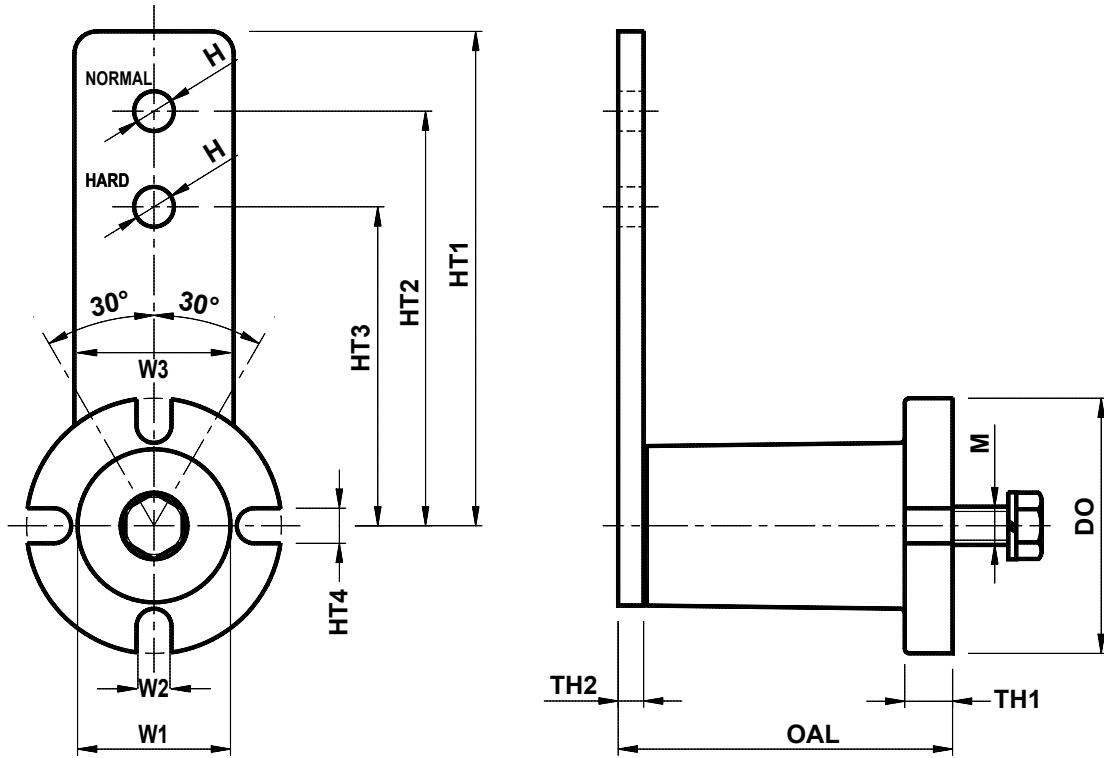

Type	OD	OAL	TH1	HT2	HT3	W3	HT1	W1	W2	TH2	HT4	H	M	F in n/M 0 - 30°	Weight (kg)
SE11	35	50	5	80	60	20	90	20	7	7	6	8	M6	0-90	0.25
SE15	50	60	5	100	80	30	110	22	8	8	8	10	M8	0-140	0.45
SE18	60	75	6	100	80	40	115	35	9	10	11	10	M10	0-320	0.75
SE27	80	110	8	135	105	50	155	45	10	15	13	12	M12	0-820	1.8
SE38	105	140	10	180	140	65	200	62	13	16	15	20	M16	0-1500	3.7
SE45	115	200	12	225	190	70	260	78	17	18	20	20	M20	0-2500	6.5

All measurements in mm.

Type	Angle of Pretension (Force required in psi)						Mounting Bolt Torque
	10°		20°		30°		
	Normal	Hard	Normal	Hard	Normal	Hard	
SE11	3.4	4.5	9.0	11.9	18.0	23.9	89
SE15	5.6	7.0	14.6	18.2	30.4	37.8	221
SE18	16.9	20.9	40.5	50.6	78.7	98.2	434
SE27	33.8	43.8	85.4	111.1	179.8	233.8	761
SE38	65.3	81.4	164.1	205.0	337.2	4215	1859
SE45	112.5	140.5	292.5	365.6	584.5	730.7	3629

The optimum angle of pretension is 20°, the maximum angle is 30°. At 20° the tensioner has maximum capability to absorb vibrations and shock loads, and still have enough arc motion to automatically take up belt or chain stretch.

Tensioner Selection		
Chain	Belt	Tensioner
25-1	A	SE11
35-1-2-3	A, B	SE15
35-1-2-3	B, C	SE18
40-1-2-3		
40-3		
50-1-2-3	D, E	SE27
60-1-2-3		
80-1-2-3	-	SE38
80-3		
100-1-2-3		
120-1-2-3		
140-1-2	-	SE45
160-1-2		
180-1-2		
200-1-2		

Block Tensioner Arm - OVR Sliding

The OVR Sliding Block Tensioner Kit is engineered for efficient chain tensioning in industrial applications. Made from high molecular density polyethylene, its unique oval design enables double-sided use for extended lifespan and versatility. Suitable for operating speeds up to 20 m/min and temperatures up to 70°C, the OVR kit is available in simplex and duplex versions to fit a variety of chain sizes.



Features

- ▶ High molecular density polyethylene construction for durability
- ▶ Dual-sided oval design for extended wear life
- ▶ Compatible with simplex (“S”) and duplex (“D”) chain systems
- ▶ Low friction, high wear resistance
- ▶ Operating speed ≤ 20 m/min
- ▶ Operating temperature ≤ 70°C
- ▶ Multiple sizes available for different chain types

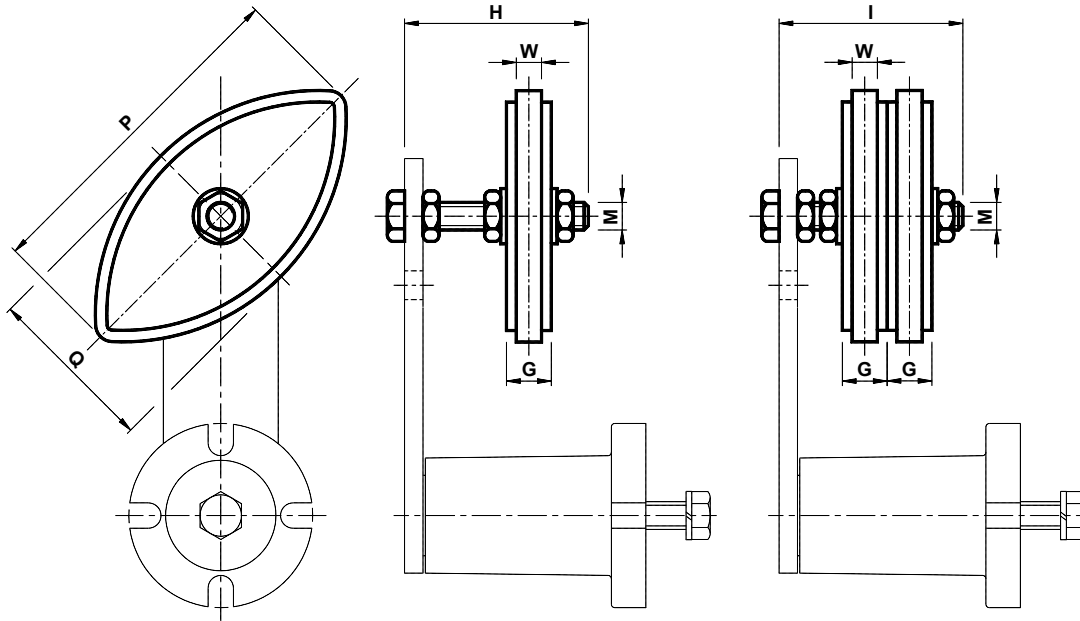

Type	Simplex	Duplex	Chain	Size	A	B	C	E	G	H	I	L	M	P	Q	R	W	Weight kg		
																		S	D	T
OVR 10-1	RE011030	RE011040	3/8" x 7/32"	10	10	18		10	10.2	45	45		M8	75	40	35	5	0.09	0.10	
OVR 20-2	RE011032	RE011042	1/2" x 5/16"	20	14	20.5		10	13.9	55	55		M10	96	50	35	7	0.10	0.11	
OVR 30-2	RE011032	RE011044	1/2" x 5/16"	30	14	20.5	34	10	13.9	55	60	70	M10	96	50	35	7	0.11	0.12	0.13
OVR 30-3	RE011034	RE011046	5/8" x 3/8"	30	16.5	25		12	16.6	55	70		M10	126	65	45	9	0.12	0.14	
OVR 30-4	RE011036	RE011048	1/2" x 5/16"	30	17.5	30		12	19.5	60	70		M10	148	74	45	11	0.13	0.15	
OVR 40-4	RE011038	RE011050	1/2" x 5/16"	40	17.5	30	49	12	19.5	80	80	100	M12	148	74	45	11	0.20	0.22	0.28

All measurements in mm unless otherwise stated.

Block Tensioner Arm - SB Bracket

The SB Bracket is a robust steel support designed to simplify the mounting of elastic elements, such as chain tensioners, onto machinery. It features dedicated mounting bores for secure fixation and is available in multiple sizes to suit various applications.

Features

- ▶ Facilitates quick and secure assembly of elastic elements on machines
- ▶ Made from durable steel for industrial reliability
- ▶ Multiple size options for compatibility with different setups
- ▶ Dedicated bore for easy fixation of CRESA tensioners (types RE, FE)
- ▶ Lightweight and compact design for versatile installation

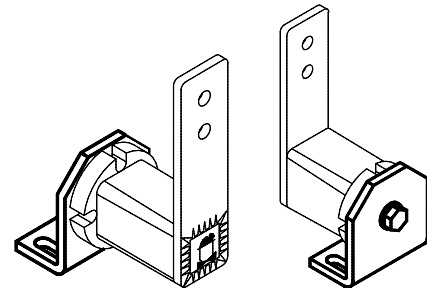
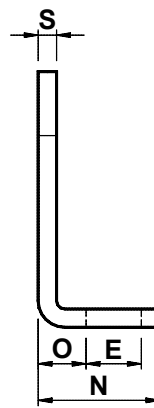
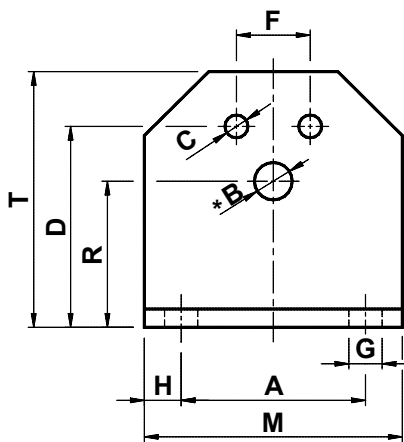

Type	Code No.	A	Size	B	C	D	E	F	G	H	M	N	O	R	S	T	Weight kg
SB10	RE020510	30	10	6.5	5.5	35	13	10	7	7.5	45	30	11.5	27	4	46	0.09
SB20	RE020511	40	20	8.5	6.5	44	13	12	7	7.5	55	32	13.5	34	5	58	0.17
SB30	RE020512	50	30	10.5	8.5	55	15.5	20	9.5	10	70	38	16.5	43	6	74	0.29
SB40	RE020513	65	40	12.5	10.5	75	21.5	25	11.5	12.5	90	52	21	57	8	98	0.72
SB50	RE020514	80	50	16.5	12.5	85	24	35	14	15	110	55	21	66	8	116	0.93
SB60	RE020515	100	60	20.5	12.5	110	30	40	18	20	140	66	26	80	10	140	1.82

All measurements in mm unless otherwise stated.

Block Tensioner Arm - SE Idler Sprocket

The SE idler sprocket for tensioner arms is a durable, maintenance-free sprocket designed for SE series chain tensioners. It ensures smooth chain operation and reliable tensioning across various chain sizes.

Ideal for conveyors and industrial machinery requiring consistent, trouble-free chain tension.

Features

- ▶ Automatically compensates for chain slack
- ▶ Reduces wear and extends chain life
- ▶ Minimises vibration and noise
- ▶ Easy installation and adjustment
- ▶ Maintenance-free, durable construction
- ▶ Enhances power transmission efficiency

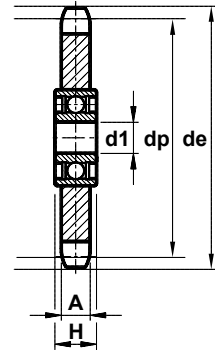

Part No	Pitch	Teeth	de	dp	A	d1	Bolt	H
SE15/SE18-06B-15	3/8"	15	49.5	45.8	5.3	10	10x55	9
SE15/SE18-08B-15	1/2"	15	65.9	61.1	7.2	10	10x55	9
SE27-08B-15	1/2"	15	65.9	61.1	7.2	12	12x80	9
SE27-10B-15	5/8"	15	83.2	76.4	9.1	12	12x80	10
SE27-12B-15	3/4"	15	99.8	91.6	11.1	12	12x80	11.1
SE38-10B-15	5/8"	15	83.2	76.4	9.1	20	20x100	14
SE38-12B-15	3/4"	15	99.8	91.6	11.1	20	20x100	14
SE38-16B-13	1"	13	117.7	106.1	16.2	20	20x100	16
SE45-20B-13	1-1/4"	13	147.5	132.7	18.5	20	20x100	18

All measurements are in mm.

Block Tensioner Arm - SE Belt Roller

The durable nylon roller is specially designed for optimal belt tensioning on SE-11, SE-15/18, SE-27, SE-38, and SE-45 Arms. Made from high-quality, wear-resistant nylon, it ensures smooth, quiet operation and extends the lifespan of your equipment by maintaining consistent belt tension.

Features

- ▶ Compatible with multiple SE arm models for versatile use
- ▶ High durability reduces wear and maintenance needs
- ▶ Smooth operation minimises noise and vibration
- ▶ Extends belt and equipment life by preventing slippage
- ▶ Easy to install and maintain for improved uptime

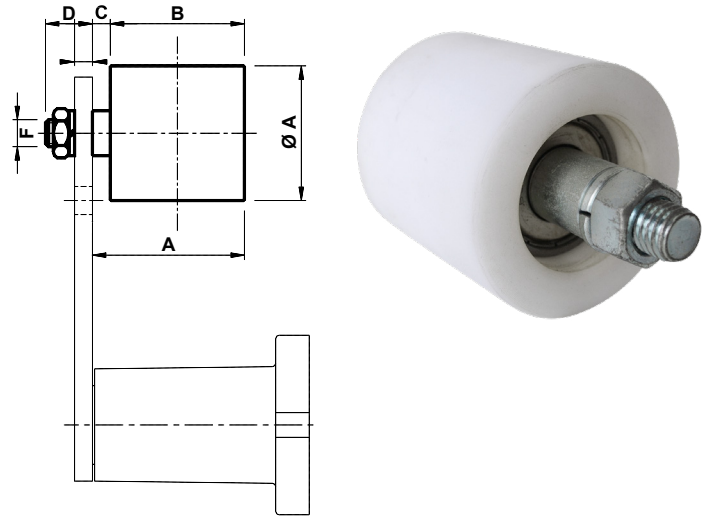

Part No	Max Speed	Max Belt Width	A	B	C	D	E	F	Weight kg
	RPM								
SE11-BT30X35	8000	30	30	35	2	14	5	M8	0.08
SE15/18-BT40X45	8000	40	40	45	6	16	7	M10	0.17
SE27-BT60X60	6000	55	60	60	8	17	8	M12	0.4
SE38-BT80X90	5000	85	80	90	8	25	10	M20	1.15
SE45-BT80X135	4500	130	90	135	10	27	12	M20	1.75

All measurements are in mm.

Block Tensioner Arm - SP (Z-A-B) Pulley

The SP pulley features a durable nylon roller designed for V-belts (profiles Z, A, B) compatible with SE-11, SE-15/18, SE-27, SE-38, and SE-45 arms. Mounted on lubricated bearings, it ensures smooth, maintenance-free operation. Available in single, double, or triple groove configurations to suit various belt setups. Custom profiles and cogged belt options are available upon request.



Features

- ▶ Reliable, consistent belt tension for smooth operation
- ▶ Reduces belt wear and slippage, extending equipment life
- ▶ Maintenance-free with lubricated bearings
- ▶ Minimises noise and vibration
- ▶ Versatile groove options for different belt configurations
- ▶ Resistant to dust and harsh environments
- ▶ Ideal for enhancing performance and longevity of your SE arm belt systems.

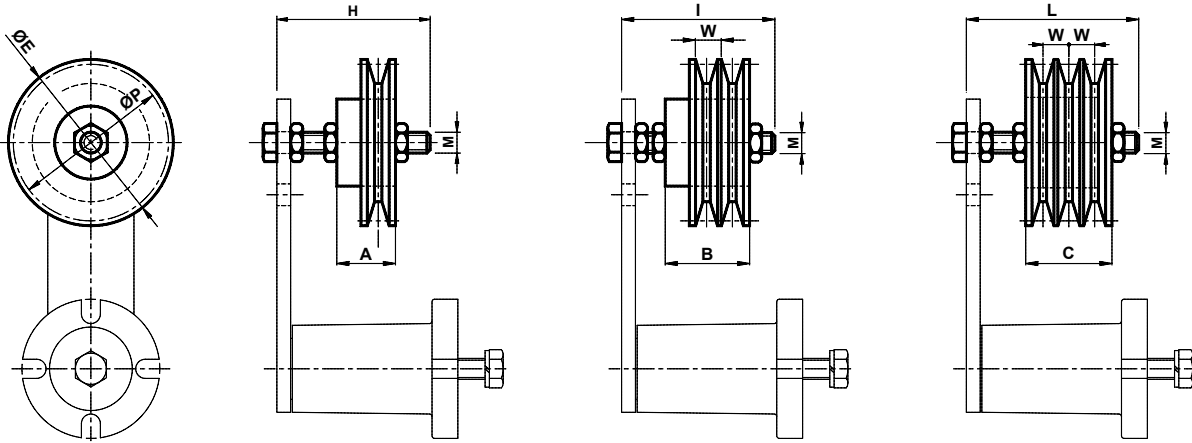

Type	S	D	T	Belt	Size	A	B	C	ØE	H	I	L	M	ØP	W	Weight kg		
																S	D	T
SP 30-Z	RE011800	RE011802	RE011804	SPZ	30	24	35	40	67	55	60	70	M10	63	12	0.40	0.70	1.10
SP 40-A	RE011806	RE011808	RE011810	SPA	40	34	49	50	95.6	80	80	80	M12	90	15	1.00	0.70	1.10
SP 40-B	RE011812	RE011814		SPB	40	41	60		132	90	80		M12	125	19	1.90	2.80	
SP 50-B			RE011816	SPB	50			63	132			120	M20	125	19			3.50

All measurements in mm unless otherwise stated.

TRANSDRIVE[®]

DRIVE PERFORMANCE

Need more information about
TransDrive products, customised
products and services, get in touch.

info@transdrive.com.au
transdrive.com.au

Supplier

