

# TRANS DRIVE<sup>®</sup>

## DRIVE PERFORMANCE



**Industrial Chain**

[transdrive.com.au](http://transdrive.com.au)

# TRANSDRIVE<sup>®</sup>

## DRIVE PERFORMANCE

TransDrive was established to bring together our passion and experience in power transmission by being able to offer affordable, high-quality products to the power transmission and bearing market. Built on the philosophy of improving performance and quality of all of our TransDrive products.

Transdrive products have been manufactured and tested to meet ISO standards and the tough, working conditions of heavy industries.

Our team have experience in power transmission and bearings. Every product we design and manufacture is backed by years of industry knowledge and an understanding of what our customers and the market need.

At TransDrive, our goal is simple: to provide accessible, high-quality products at affordable pricing. With an unwavering commitment to excellence, TransDrive operates with a focus on providing innovative industry solutions.

Whether it is through our custom products, the standard range of pulleys, slew drives, chains and sprockets, TransDrive is dedicated to delivering effective solutions for the trades that offer increased productivity and reliability.

## Development & Standards

### Stable supply of raw material

Our raw material supplier guarantees our product quality from the beginning. Each material batch is double analysed for quality and controlled by a spectrum analyser before use.

### High accuracy chain parts forming process control

All model chain plates are subject to a twice punching process, ensuring holes straightness. Also, pin use auto chamfering ensures assembly guidance quality.

### Reliable heat treatment system

Superb and reliable heat treatment system makes sure all chain parts are evenly heat treated, and evenly cooled. Retained austenite of case-hardened parts be efficiently controlled.

### Advanced automatic assembly system

Instead of traditional manual assembling. We have an advanced equipment set, making certain of reliable, stable assembly quality. Even auto assembling of all types K of attachment plates.

### Standards

As standard all TransDrive Chains come in boxes of 10ft (3.048m) with 2x links per pack.



# Contents

## Introduction 4

Chain Construction & Components 4

Customisation 6

## Roller Chains 7

ANSI Standard Roller Chain 8

BS Standard Roller Chain 15

Industrial O-Ring Chain 19

Heavy Series H 20

Super Heavy Series SH 22

Stainless Steel Chain 23

## Small Size Conveyor Chain 24

Straight Side Plates 25

Double Pitch Drive Chain 27

Double Pitch Conveyor Chain 28

Hollow Pin Chain 30

Double Pitch Hollow Pin Chain 32

Single Pitch Attachments 33

Double Pitch Attachments 42

Accumulation Conveyor Chain 58

Double Pitch Accumulation Chain 59

Side Roller Chain 60

Free Flow Chain 61

## Leaf Chains 63

AL Series Leaf Chain 64

LL / EL Series Leaf Chain 65

BL / LH Series Leaf Chain 67

FL Series Leaf Chain 70

Galle Chain 71

Rollerless Leaf Chain 72

## Engineered Conveyor Chains 73

BS Conveyor Chain 74

M Series Conveyor Chain 84

FV Series Conveyor Chain 87

SC/HC Series Conveyor Chain 90

FM Series Conveyor Chain 92

Solid Pin Conveyor Chain 99

Hollow Pin Conveyor Chain 100

High Side Plate Conveyor Chain 101

Bush Steel Conveyor Chain 103

Steel Pintel Chains 104

Cast Iron Chains 105

Welded Steel Chain 107

## Specialised Engineered Chains 111

Asphalt Chains 112

Agricultural Chain 113

Bucket Elevator Chains 115

Car Parking Chain 116

Coupling Chain 117

Mesh Belt Furnace Hoisting Chain 118

Oil Field Chains 119

Palm Oil Conveyor Chain 120

Scraper Conveyor Chains 124

Sharp Top Chain 125

Sugar Mill Chains 131

Timber Conveyor Chains 134

Tobacco Machinery Chain 135

Trencher Chains 136

## Chain Handling Tools 146

Chain Pullers, Detachers, Cutters & Punches 147

Chain Pullers, Detachers, Cutters & Punches 148

## Distributors 149

# Chain Construction & Components

Roller chain consists of pins, bushings, rollers and link plates as illustrated below.

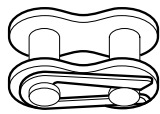
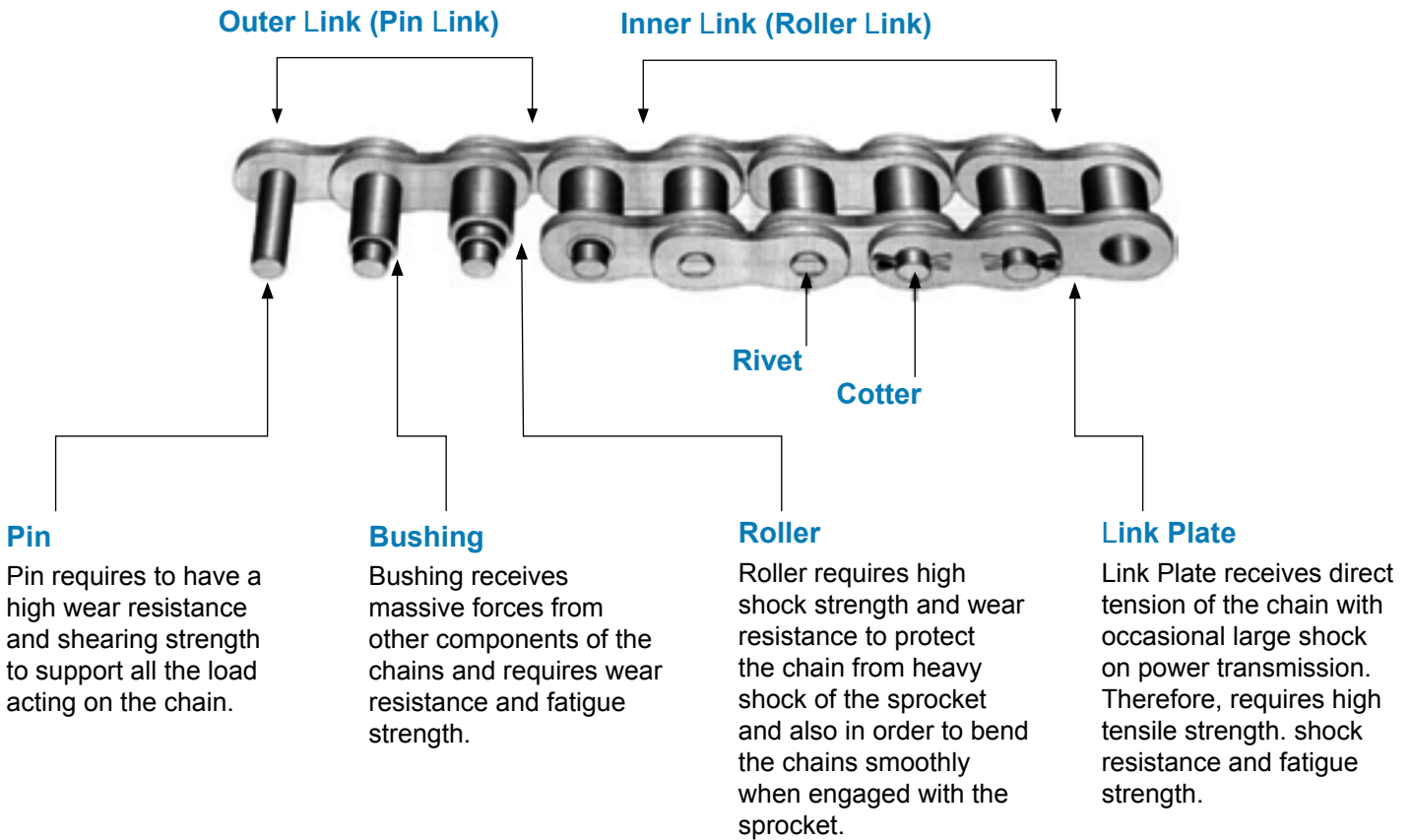

**Connecting Link**  
(Spring Clip type)

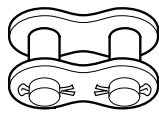

**Connecting Link**  
(Cotter Pin type)

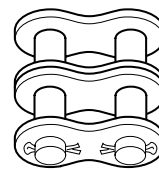

**Connecting Link**  
(Duplex)

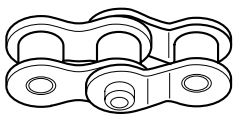

**Two Pitch Half Link**

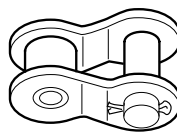

**Half Link**  
(Cotter Pin type)

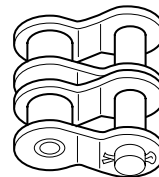

**Half Link**  
(Duplex)

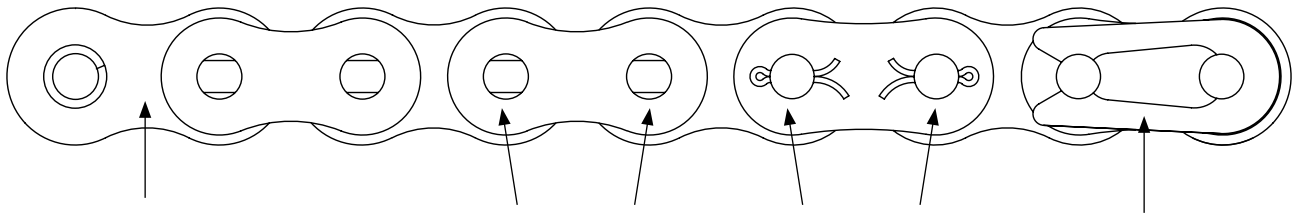

**Roller Link**  
(Type R/L)

**Rivet**  
(Type R)

**Cotter**  
(Type C)

**Spring Clip**  
(Type Sp CL)

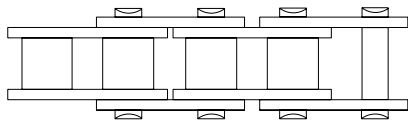
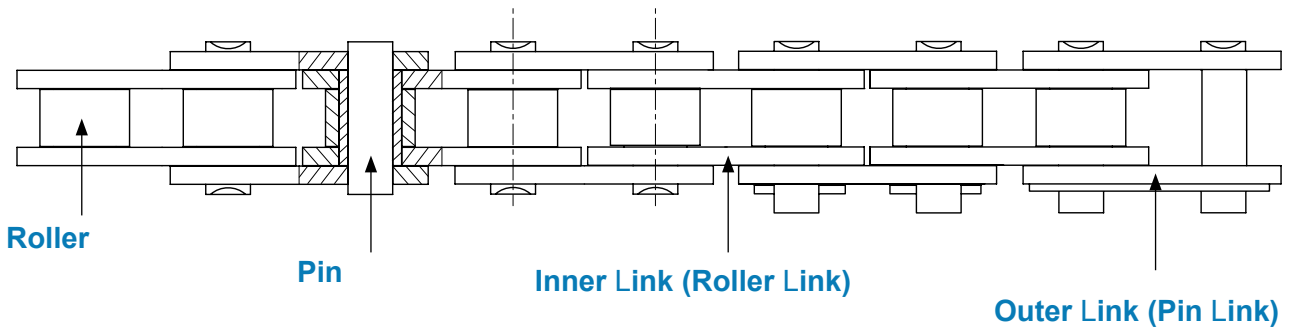

**Simplex**

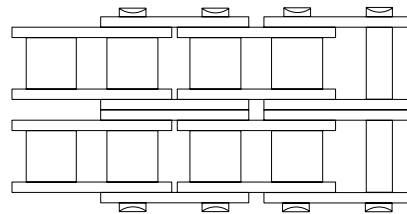

**Duplex**

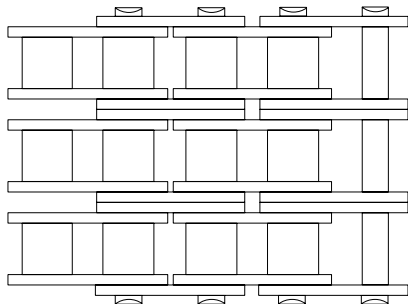

**Triplex**

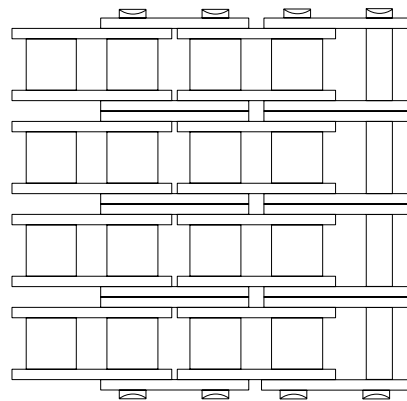

**Quadruplex**

## Customisation

### Tailored to any specifications

Due to the wide range of industrial chains, we are only including a limited selection of chain types in this catalogue.

Our development team can produce factory samples to meet your needs based on drawings, samples or specifications and can produce rapid prototypes for testing.

### High strength roller chains

Please contact us with any requests regarding “high strength” roller chains, we can produce chains with tensile strengths 1.6x times stronger than standard roller chains. Accepted high-strength chain applications include:

- ▶ Space limitation, where bigger-sized chains are not accepted.
- ▶ High safety co-efficiency.
- ▶ High extraction force of roller chain.
- ▶ High tensile strength.

### Different options of chain surface treatment

Surface treatment	Function	Factory Suggestion	Notes
Natural colour	Keeps natural steel colour	Recommend	Energy saving and environmentally friendly
Shot blasting	Increases fatigue strength	Recommend	Standard
Surface dacromet	Increases anti-rust properties	Recommend	Available on request
Surface blackening	Increases anti-rust properties	Not recommend	Non eco-friendly
Surface nickel-plated	Increases anti-rust properties	Not recommend	Non eco-friendly, higher cost
Surface zinc plated	Increases anti-rust properties	Not recommend	Reduces chain strength, hydrogen embrittlement

### Different part options

#### Chain plate

- ▶ Standard peanut type plate, standard straight type plate
- ▶ Plate with various welded attachments
- ▶ Plate with a central hole
- ▶ Plate with shot blasting, dacromet or zinc plate.
- ▶ Plate with various bending attachments

#### Chain bush

- ▶ Standard straight bush
- ▶ Step bush
- ▶ Bush with locking ring

#### Chain roller

- ▶ Standard cylinder-shaped (smaller) roller
- ▶ Non-metal material roller
- ▶ Standard cylinder-shaped (bigger) roller
- ▶ F roller

#### Chain pin

- ▶ Standard straight type pin
- ▶ Step pin
- ▶ Carbonised pin treatment
- ▶ Rotating round rivet pin
- ▶ Hollow pin
- ▶ Induction hardened chrome

# Roller Chains

Also known as a transmission chain or drive chain.

The roller chain is a type of industrial chain specifically designed for power transmission applications.

It is used to transmit rotational motion and torque from a power source, such as an electric motor or an engine, to a driven component, such as a conveyor system, machinery, or equipment.

## Our range

- ▶ ANSI Standard
- ▶ BS Standard
- ▶ Industrial O-Ring
- ▶ Heavy Duty
- ▶ Super Heavy Series
- ▶ Stainless Steel



# ANSI Standard Roller Chain

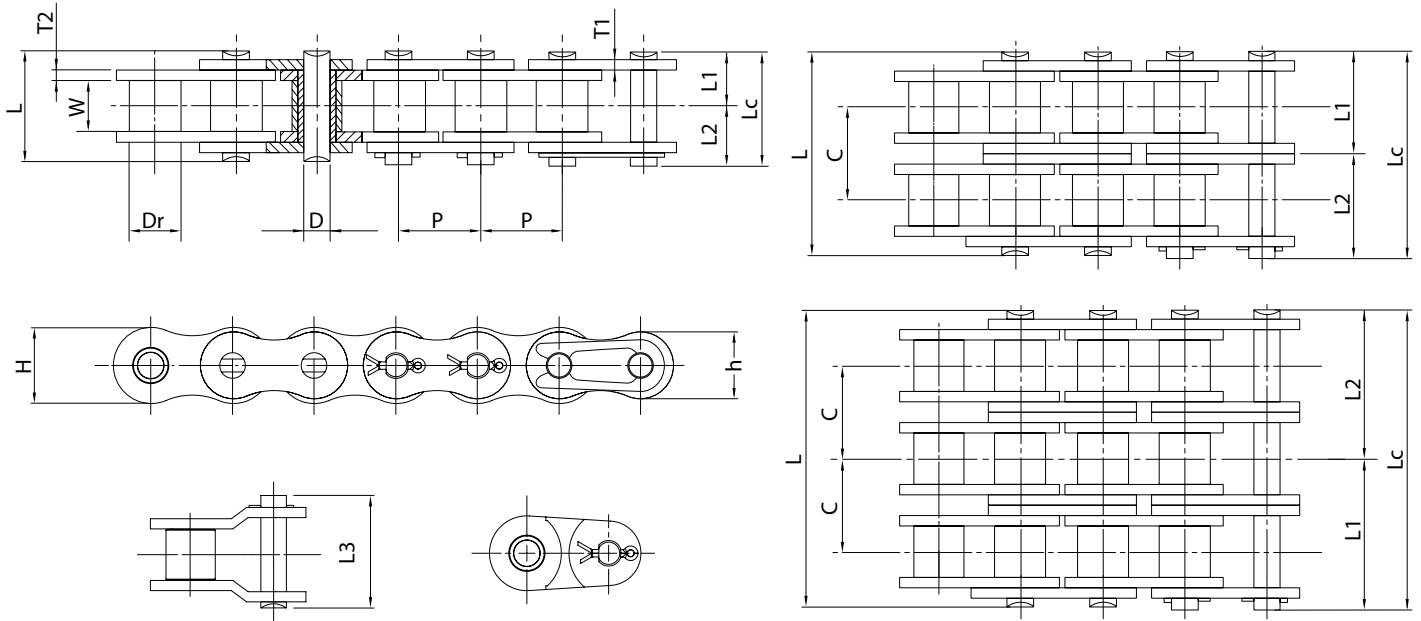

## 25 - 40 Size Chart (mm)

ANSI Chain No.	Pitch P	Roller Diameter max Dr	Width Between Inner Plates min W	Pin Diameter max D	Plate Thickness max		Inner Plate Depth max H
					T1	T2	
*25	6.35	3.30	3.10	2.31	0.8	0.8	6.02
*35	9.53	5.08	4.68	3.58	1.3	1.3	8.70
40	12.70	7.95	7.85	3.96	1.5	1.5	12.07

\*Bush chain: d1 indicate the external diameter of the bushing.

## 25 - 40 Load Ratings Chart (mm)

ANSI Chain No.	Pin Length					Transverse Pitch C	Average Tensile Strength kN	Tensile Strength min kN	Weight Per Metre kg/m	Ultimate Tensile Strength Q (ISO/DIN) min kN	Average Tensile Strength Q0 kN
	L max	Lc max	L1 max	L2 max	L3 max						
*25-1	9.1	9.35	4.55	4.8	9.65	6.4	4.3	3.5	0.15	3.5	4.3
*25-2	15.5	15.75	7.75	8	16.05		8.6	7	0.29	7	8.6
*25-3	21.8	22.1	10.9	11.2	22.45		12.9	10.5	0.45	11	12.9
*35-1	9.3	13.45	6.6	6.85	14.25	10.13	9	7.9	0.31	7.9	9
*35-2	22.5	23.6	11.7	11.9	25.3		18.2	15.8	0.72	15.8	18.2
*35-3	32.7	33.65	16.75	16.9	35.35		27.3	23.7	1.1	23.7	27.3
40-1	17.80	18.85	8.90	9.95	19.05	14.38	17.80	0.64	0.64	19.20	4.17
40-2	32.30	33.30	16.15	17.15	34.10		35.60	27.60	1.28	38.40	6.37
40-3	46.70	47.50	23.35	24.15	48.60		53.40	41.40	1.93	57.7	9.31
40-4	61.15	61.87	30.57	31.3	14.25		71.20	—	2.55	76.9	12.2
40-5	75.60	76.40	37.80	38.6	25.30		89.00	—	3.18	97	14.5
40-6	90.05	90.82	45.02	45.8	35.35		106.80	—	3.80	105	16.8

\*Bush chain: d1 indicate the external diameter of the bushing.



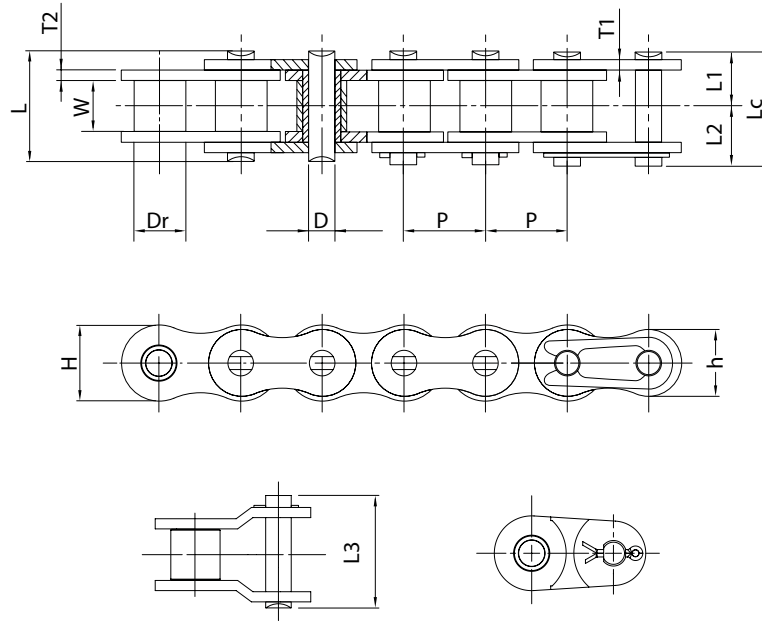

### 41 - 415H Size Chart & Load Ratings (mm)

ANSI Chain No.	Pitch P	Roller Diameter max Dr	Width Between Inner Plates min W	Pin Diameter max D	Plate Thickness max		Inner Plate Depth max H	Pin Length		Weight Per Metre kg/m	Ultimate Tensile Strength Q (ISO/DIN) min kN	Average Tensile Strength Q0 kN
					T1	T2		L max	Lc max			
41	12.70	7.77	6.25	3.58	1.25	1.25	9.91	13.75	16	0.41	6.8	11.8
410	12.70	7.75	3.40	3.64	1.0	1.0	9.5	9.3	10.7	0.28	5.9	9.81
415	12.70	7.77	4.76	3.60	1.0	1.0	9.7	11	12.4	0.32	6.86	7.6
415H	12.70	7.77	4.76	3.96	1.5	1.5	12	13.1	14.5	0.55	14.4	7.6

# ANSI Standard Roller Chain

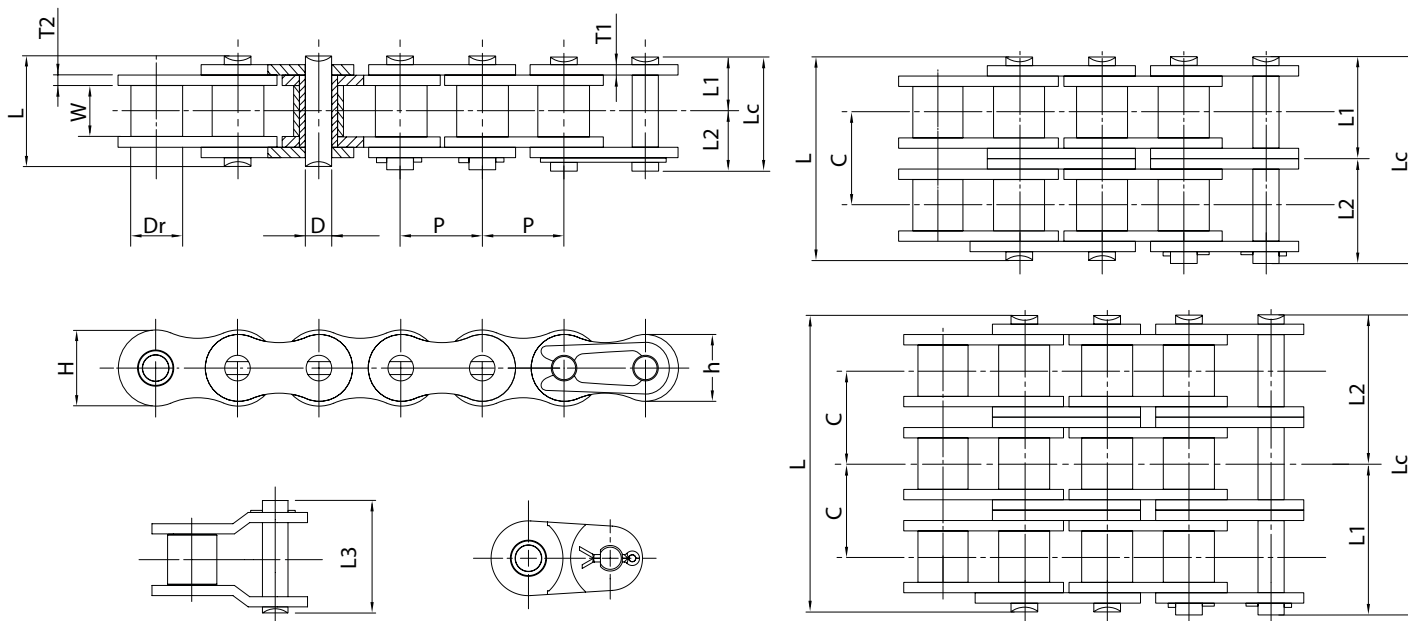

## 50 Size Chart (mm)

ANSI Chain No.	Pitch P	Roller Diameter max Dr	Width Between Inner Plates min W	Pin Diameter max D	Plate Thickness max		Inner Plate Depth max H
					T1	T2	
50	15.875	10.16	9.40	5.09	2.03	2.03	15.09

## 50 Load Ratings Chart (mm)

ANSI Chain No.	Pin Length					Transverse Pitch C mm	Average Tensile Strength kN	Tensile Strength min kN	Weight Per Metre kg/m	Ultimate Tensile Strength Q (ISO/DIN) min kN	Average Tensile Strength Q0 kN
	L max	Lc max	L1 max	L2 max	L3 max						
50-1	21.80	22.90	10.90	12.00	94.30	18.11	29.20	21.80	1.05	31.9	7.2
50-2	39.90	41.10	19.95	21.15	39.90		58.40	43.60	2.01	63.7	10.5
50-3	57.90	59.15	28.95	30.20	57.90		87.67	65.40	3.13	95.6	15.6
50-4	76.10	77.30	38.05	39.25	76.10		116.80	—	4.15	127	20.3
50-5	94.30	95.45	47.15	48.30	94.30		146.00	—	5.19	156.3	26.8
50-6	112.50	113.65	56.25	57.40	112.50		175.20	—	6.21	188.5	30.7

# ANSI Standard Roller Chain

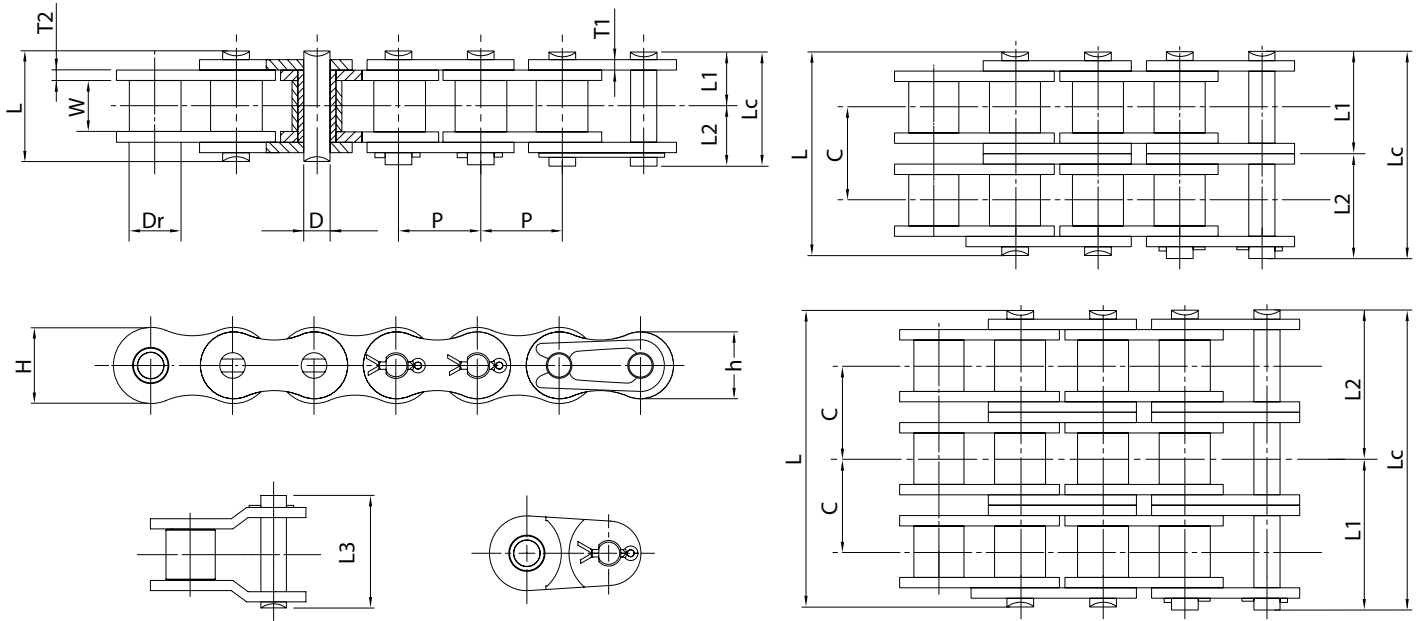

## 60 - 80 Size Chart (mm)

ANSI Chain No.	Pitch P	Roller Diameter max Dr	Width Between Inner Plates min W	Pin Diameter max D	Plate Thickness max		Inner Plate Depth max H
					T1	T2	
60	19.05	11.91	12.57	5.96	2.42	2.42	18.08
80	25.40	15.88	15.75	7.94	3.25	3.25	24.13

## 60 - 80 Load Ratings Chart (mm)

ANSI Chain No.	Pin Length					Transverse Pitch C	Average Tensile Strength kN	Tensile Strength min kN	Weight Per Metre kg/m	Ultimate Tensile Strength Q (ISO/DIN) min kN	Average Tensile Strength Q0 kN
	L max	Lc max	L1 max	L2 max	L3 max						
60-1	26.90	28.20	13.45	14.75	28.80	29.78	41.60	31.10	1.54	43.10	10.70
60-2	49.80	51.15	24.90	26.25	52.85		83.20	62.30	3.06	86.3	14.70
60-3	72.60	74.45	36.30	38.15	76.15		124.80	93.40	4.57	129	21.50
60-4	95.40	97.25	47.70	49.55	98.95		166.40	—	6.08	173	28.50
60-5	118.20	59.10	61.00	38.6	25.30		208.00	—	7.59	216	33.70
60-6	141.00	70.50	72.50	45.8	35.35		249.60	—	9.11	259	39.70
80-1	33.50	36.00	16.75	19.25	36.50	29.29	72.00	55.60	2.70	78.50	19.10
80-2	62.70	65.25	31.35	33.90	67.95		142.00	111.20	5.32	157	25.00
80-3	91.90	94.45	45.95	48.50	97.15		216.00	166.80	8.01	235	36.70
80-4	121.20	60.60	63.25	39.25	76.10		288.00	—	10.66	314	48.50
80-5	150.50	75.25	77.95	48.30	94.30		360.00	—	13.31	393	57.3
80-6	179.80	89.90	92.50	57.40	115.05		432.00	—	15.98	471	67.60

# ANSI Standard Roller Chain

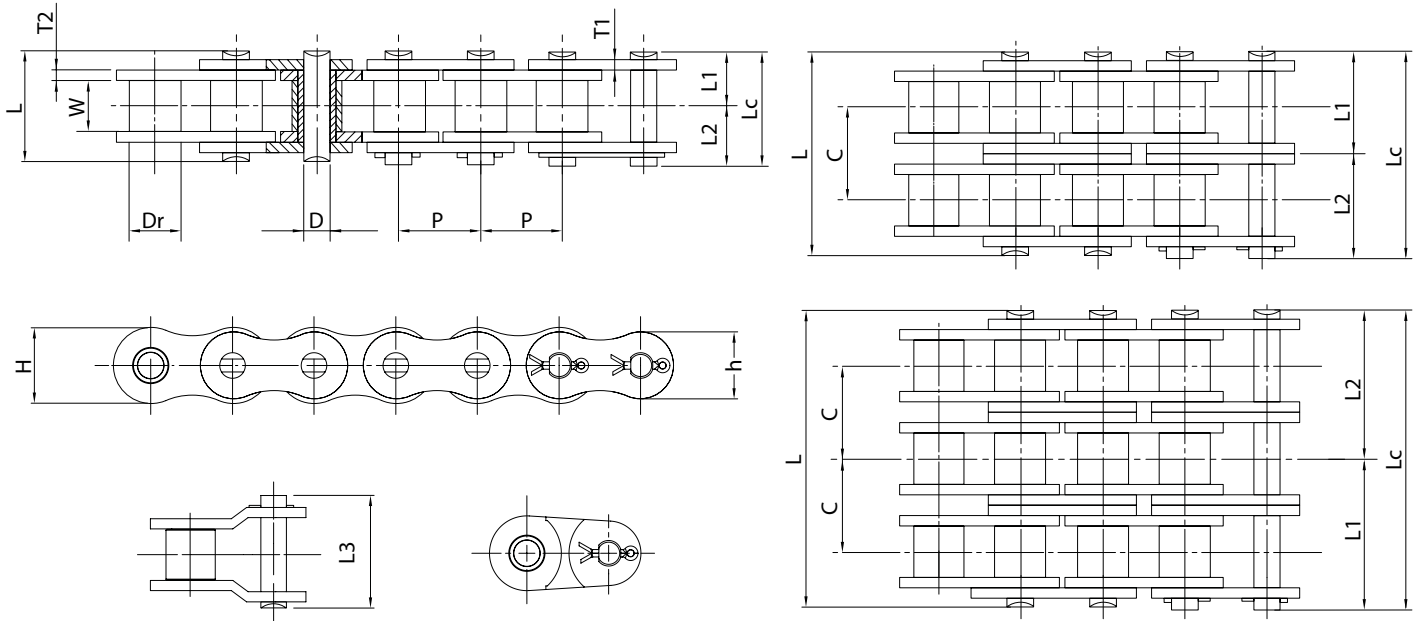

## 100 - 120 Size Chart (mm)

ANSI Chain No.	Pitch P	Roller Diameter max Dr	Width Between Inner Plates min W	Pin Diameter max D	Plate Thickness max		Inner Plate Depth max H
					T1	T2	
100	31.75	19.05	18.90	9.54	4.0	4.0	30.18
120	38.10	22.23	25.22	11.11	4.8	4.8	36.20

## 100 - 120 Load Ratings Chart (mm)

ANSI Chain No.	Pin Length					Transverse Pitch C	Average Tensile Strength kN	Tensile Strength min kN	Weight Per Metre kg/m	Ultimate Tensile Strength Q (ISO/DIN) min kN	Average Tensile Strength Q0 kN
	L max	Lc max	L1 max	L2 max	L3 max						
100-1	41.10	43.40	20.55	22.85	45.20	35.76	110.20	86.70	4.00	118	29.40
100-2	77.00	79.30	38.50	40.80	82.10		220.40	173.50	7.87	235	38.30
100-3	113.00	115.25	56.50	58.75	118.05		330.00	260.20	11.80	353	56.30
100-4	148.90	151.10	74.45	76.65	153.90		440.80	—	15.74	471	74.40
100-5	184.80	187.00	92.40	94.60	189.80		551.00	—	19.58	590	88.10
100-6	220.70	222.90	110.35	112.55	225.70		662.00	—	23.84	708	104
120-1	50.80	54.30	25.40	28.90	56.30	45.44	157.20	124.60	5.95	167	39.50
120-2	96.30	99.75	48.15	51.60	103.55		314.40	249.10	11.73	333	51.60
120-3	141.70	145.25	70.85	74.40	149.05		471.60	373.70	17.55	500	76
120-4	187.20	190.70	93.60	97.10	194.50		628.80	—	23.40	667	100
120-5	232.70	236.20	116.35	119.85	240.00		786.00	—	29.20	835	119
120-6	278.20	281.65	139.10	142.55	285.45		943.20	—	35.00	1002	140

# ANSI Standard Roller Chain

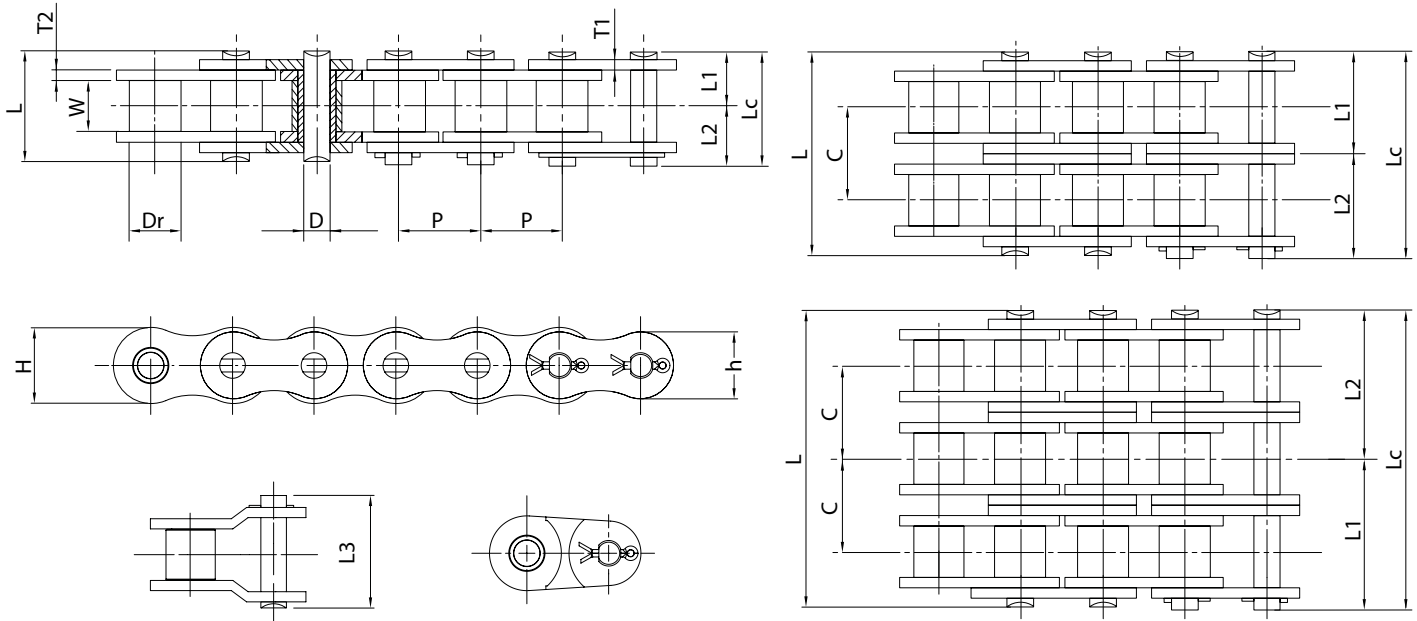

## 140 - 160 Size Chart (mm)

ANSI Chain No.	Pitch P	Roller Diameter max Dr	Width Between Inner Plates min W	Pin Diameter max D	Plate Thickness max		Inner Plate Depth max H
					T1	T2	
140	44.45	25.40	25.22	12.71	5.6	5.6	42.24
160	50.8	28.58	31.55	14.29	6.4	6.4	48.26

## 140 - 160 Load Ratings Chart (mm)

ANSI Chain No.	Pin Length					Transverse Pitch C	Average Tensile Strength kN	Tensile Strength min kN	Weight Per Metre kg/m	Ultimate Tensile Strength Q (ISO/DIN) min kN	Average Tensile Strength Q0 kN
	L max	Lc max	L1 max	L2 max	L3 max						
140-1	54.90	59.15	27.45	31.70	60.05	48.87	210.00	193	7.50	216	52.30
140-2	103.60	107.95	51.80	56.15	112.65		420.00	386	14.88	431	68.30
140-3	152.40	156.95	76.20	80.75	161.65		630.00	579	22.26	647	100
140-4	201.30	205.85	100.65	105.20	210.55		840.00	772	28.66	863	132
140-5	250.20	254.70	125.10	129.60	259.40		1050.00	965	37.06	1075	157
140-6	299.10	303.75	149.55	154.20	308.45		1260.00	—	44.40	—	—
160-1	65.50	69.60	32.75	36.85	71.90	58.55	275.00	245	10.12	275	69
160-2	124.20	128.25	62.10	66.15	133.05		550.00	490	20.08	549	90
160-3	182.90	186.90	91.45	95.45	191.70		825.00	735	30.08	824	127
160-4	241.50	245.40	120.75	124.65	250.20		1100.00	980	40.14	1098	174
160-5	300.10	304.00	150.05	153.95	308.80		1375.00	1225	50.00	1225	206
160-6	358.70	362.65	179.35	183.30	367.45		1650.00	—	60.05	—	—

# ANSI Standard Roller Chain

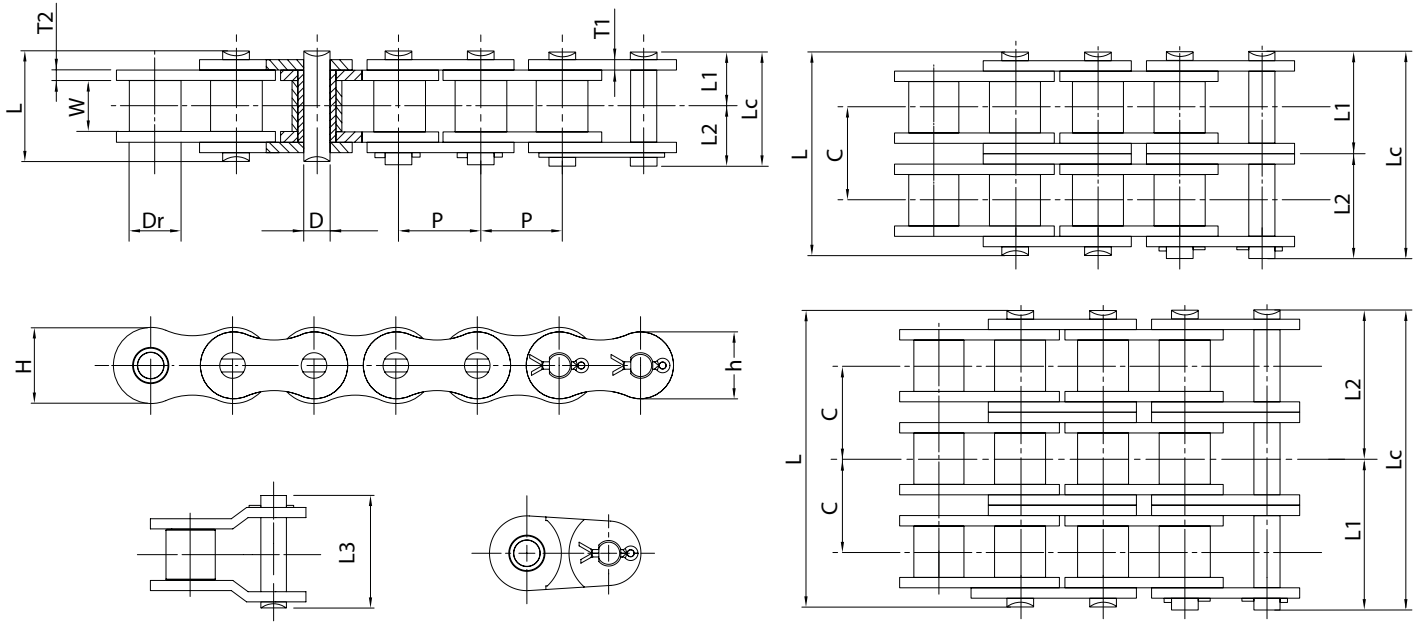

## 200 - 240 Size Chart (mm)

ANSI Chain No.	Pitch P mm	Roller Diameter max Dr mm	Width Between Inner Plates min W mm	Pin Diameter max D mm	Plate Thickness max mm		Inner Plate Depth max H mm
					T1	T2	
200	63.50	39.68	37.85	19.85	8.0	8.0	60.33
240	76.2	47.63	47.35	23.81	9.5	9.5	72.39

## 200 - 240 Load Ratings Chart (mm)

ANSI Chain No.	Pin Length - mm					Transverse Pitch C mm	Average Tensile Strength kN	Tensile Strength min kN	Weight Per Metre kg/m	Ultimate Tensile Strength Q (ISO/DIN) min kN	Average Tensile Strength Q0 kN
	L max	Lc max	L1 max	L2 max	L3 max						
200-1	80.30	84.95	40.15	44.80	88.45	71.55	456.00	347	16.52	451	93
200-2	151.90	156.60	75.95	80.65	162.40		912.00	694	32.69	902	123
200-3	223.50	228.20	111.75	116.45	234.00		1368.00	1041	49.11	1353	181
200-4	295.20	299.90	147.60	152.30	305.70		1824.00	—	65.29	1804	239
200-5	366.90	371.65	183.45	188.20	377.45		2280.00	—	82.48	2157	287
200-6	438.60	443.35	219.30	224.05	449.15		2736.00	—	97.77		
240-1	90.50	100.75	45.25	55.5	104.25	87.83	627.00	500	24.53	677	129
240-2	183.40	191.10	91.70	99.40	198.30		1254.00	1000	48.16	1353	171
240-3	271.30	278.80	135.65	143.15	286.00		1881.00	1500	71.69	2030	252
240-4	359.20	366.90	179.60	187.30	374.10		2508.00	—	95.22	2707	333
240-5	447.10	454.80	223.55	231.25	462.00		3135.00	—	118.75		
240-6	535.00	542.60	267.50	275.10	549.80		3762.00	—	142.28		

# BS Standard Roller Chain

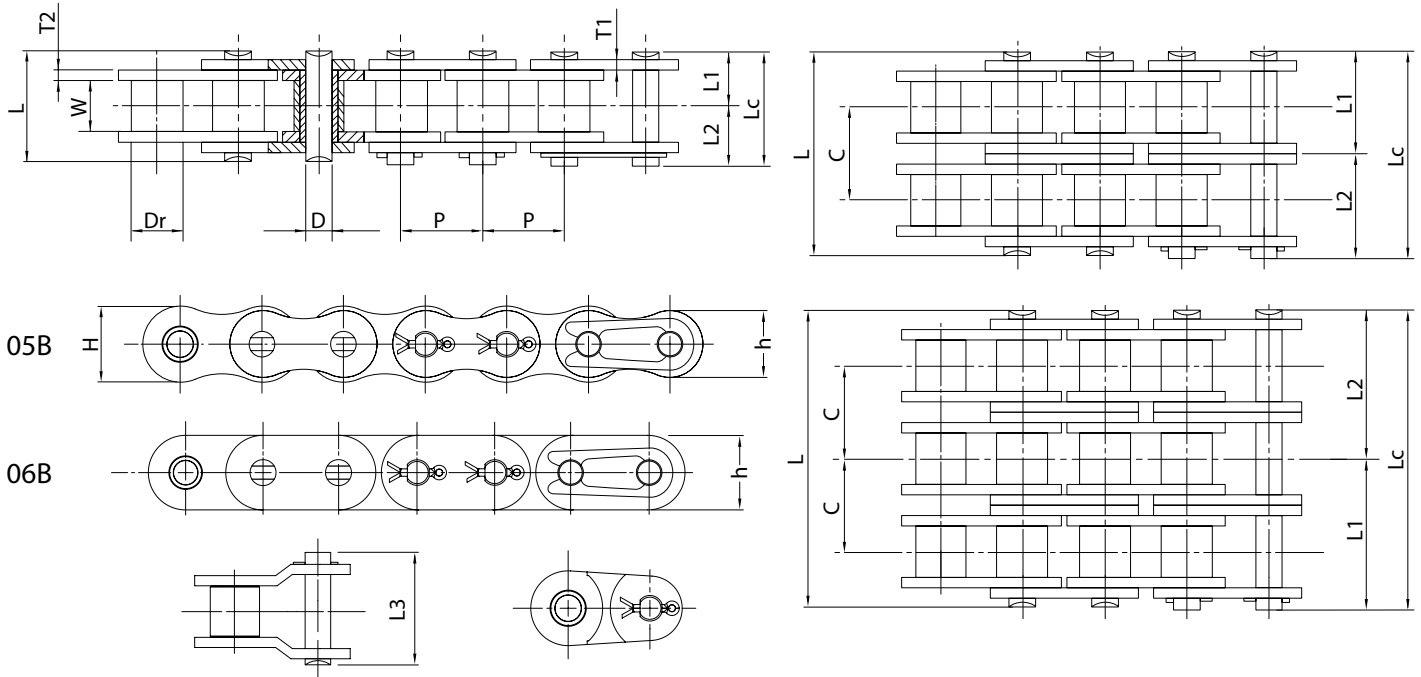

## 05B - 06B Size Chart (mm)

BS Chain No.	Pitch P	Roller Diameter max Dr	Width Between Inner Plates min W	Pin Diameter max D	Plate Thickness max		Inner Plate Depth max H	Outer Plate Depth max h
					T1	T2		
05B	8.0	5.0	3.0	2.31	0.80	0.80	7.11	7.11
06B*	9.525	6.35	5.72	3.28	1.30	1.30	8.26	8.26

## 05B - 06B Load Ratings Chart (mm)

BS Chain No.	Pin Length					Transverse Pitch C	Average Tensile Strength kN	Tensile Strength min kN	Weight Per Meter kg/m	Ultimate Tensile Strength Q (ISO/DIN) min kN	Average Tensile Strength Q0 kN
	L max	Dc max	L1 max	L2 max	L3 max						
05B-1	8.60	9.10	4.30	4.80	9.90	5.64	5.75	4.40	0.19	5.68	4.40
05B-2	14.30	14.80	7.15	7.65	16.40		9.80	7.80	0.37	9.21	7.80
05B-3	19.90	20.40	9.95	10.45	22.00		13.60	11.10	0.49		
06B-1*	13.50	14.40	6.75	7.65	14.60	10.24	9.80	8.90	0.44	8.92	1.77
06B-2*	23.80	24.47	11.90	12.57	24.70		18.00	16.90	0.85	16.9	2.9
06B-3*	34.00	34.50	17.00	17.50	34.70		28.80	24.90	1.26	24.9	4.2

\* Straight side plates.

# BS Standard Roller Chain

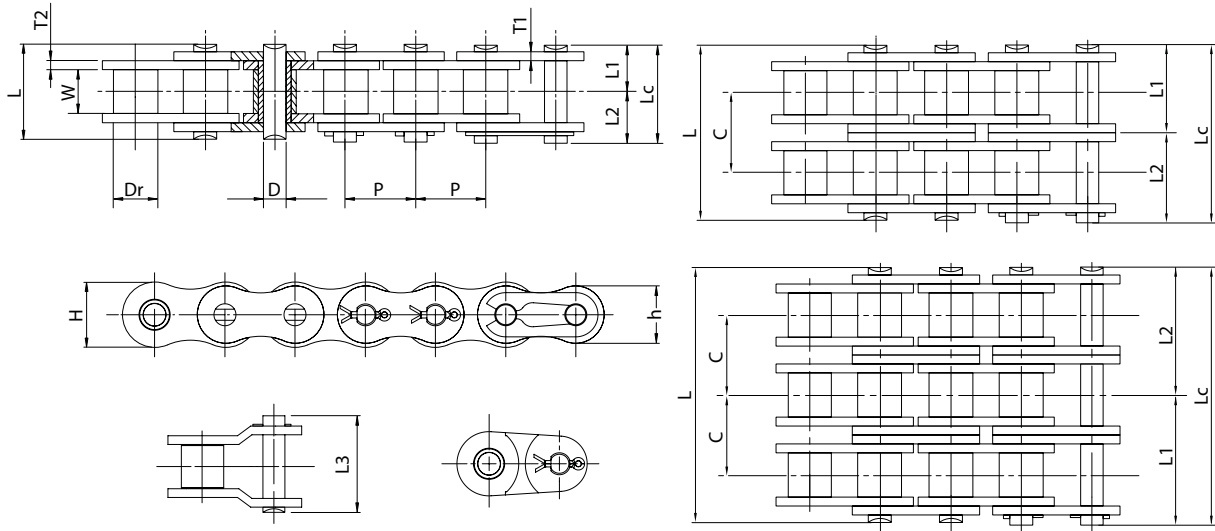

## 08B - 16B Size Chart (mm)

BS Chain No.	Pitch P	Roller Diameter max Dr	Width Between Inner Plates min W	Pin Diameter max D	Plate Thickness max		Inner Plate Depth max H	Outer Plate Depth max h
					T1	T2		
08B	12.70	8.51	7.75	4.45	1.6	1.6	11.81	10.92
10B	15.875	10.16	9.65	5.08	1.7	1.7	14.73	13.72
12B	19.05	12.07	11.68	5.72	1.85	1.85	16.13	16.13
16B	25.40	15.88	17.02	8.28	3.10	4.15	21.08	21.08

## 08B - 16B Load Ratings Chart (mm)

BS Chain No.	Pin Length					Transverse Pitch C	Average Tensile Strength kN	Tensile Strength in kN	Weight Per Metre kg/m	Ultimate Tensile Strength Q(ISO/DIN) min kN	Average Tensile Strength Q0 kN
	L max	Dc max	L1 max	L2 max	L3 max						
08B-1	17.00	18.50	8.50	10.00	18.80	13.92	18.60	17.80	0.75	17.80	3.14
08B-2	31.00	32.50	15.5	17.00	33.80		35.00	31.10	1.45	31.10	5.35
08B-3	44.90	46.40	22.45	23.95	47.80		48.80	44.50	2.15	44.50	7.85
10B-1	19.60	21.05	9.80	11.25	21.35	16.59	25.60	22.20	1.05	22.30	4.90
10B-2	36.20	37.65	18.10	19.55	39.65		50.20	44.50	2.05	44.50	8.33
10B-3	52.80	54.20	26.40	27.80	56.30		75.80	66.70	3.15	66.70	12.20
12B-1	22.70	24.35	11.35	13.0	25.05	19.46	30.30	28.90	1.28	28.90	7.06
12B-2	42.20	43.80	21.10	22.70	46.50		60.30	57.80	2.56	57.80	12
12B-3	61.70	63.30	30.85	32.45	66.20		91.00	86.70	3.89	86.70	17.60
16B-1	36.10	37.95	18.05	19.90	39.05	31.88	68.80	60.0	2.72	60.80	16.40
16B-2	68.00	69.90	34.00	35.90	73.90		136.00	106.0	5.45	106	21.40
16B-3	99.90	101.80	49.95	51.85	106.00		205.60	160.0	8.06	160	31.50



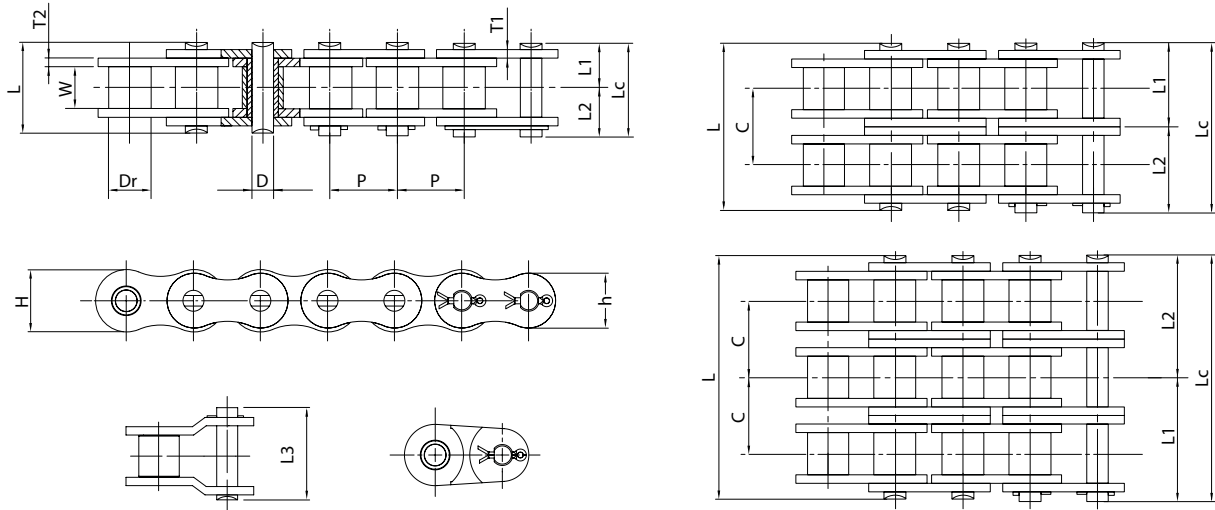

**20B - 28B Size Chart (mm)**

BS Chain No.	Pitch P	Roller Diameter max Dr	Width Between Inner Plates min W	Pin Diameter max D	Plate Thickness max		Inner Plate Depth max H	Outer Plate Depth max h
					T1	T2		
20B	31.75	19.05	19.56	10.19	3.7	4.6	26.42	26.42
24B	38.10	25.40	25.40	14.63	5.2	6.0	33.4	33.4
28B	44.45	27.94	30.99	15.90	6.3	7.5	37.08	37.08

**20B - 28B Load Ratings Chart (mm)**

BS Chain No.	Pin Length					Transverse Pitch C	Average Tensile Strength kN	Tensile Strength min kN	Weight Per Metre kg/m	Ultimate Tensile Strength Q(ISO/DIN) min kN	Average Tensile Strength Q0 kN
	L max	Dc max	L1 max	L2 max	L3 max						
20B-1	43.20	44.67	21.60	23.07	48.57	36.45	108.60	95.00	3.99	95.10	25.50
20B-2	79.70	81.07	39.85	41.22	86.57		208.40	170.00	7.93	170	33.30
20B-3	116.10	117.40	58.05	59.35	123.15		285.30	250.00	11.82	250	49
24B-1	53.4	58.20	26.70	31.5	62.30	48.36	176.80	160.00	7.55	161	35.70
24B-2	101.8	106.65	50.9	55.75	112.95		322.60	280.00	14.75	280	46.80
24B-3	150.2	155.2	75.1	80.1	161.50		489.50	425.00	21.90	425	68.80
28B-1	65.10	70.00	32.55	37.45	74.60	59.56	223.60	200.00	9.60	201	44.50
28B-2	124.70	129.57	62.35	67.22	136.97		407.50	360.00	18.90	360	58.30
28B-3	184.3	189.17	92.15	97.02	196.57		610.00	530.00	28.36	530	85.80

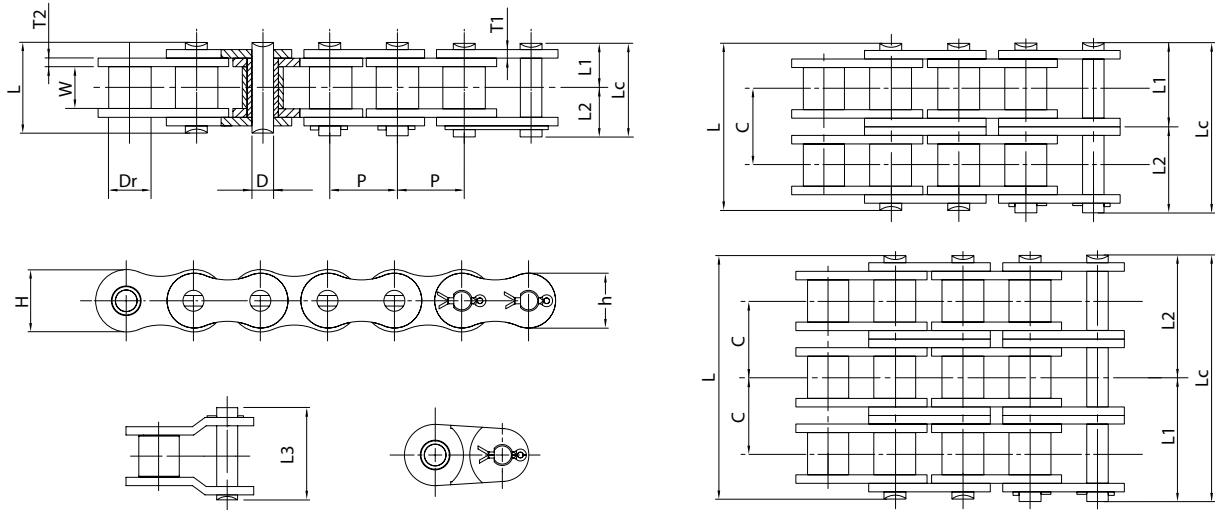

**32B - 42B Size Chart (mm)**

BS Chain No.	Pitch P	Roller Diameter max Dr	Width Between Inner Plates min W	Pin Diameter max D	Plate Thickness max		Inner Plate Depth max H	Outer Plate Depth max h
					T1	T2		
32B	50.8	29.21	30.99	17.81	6.3	7.0	42.29	42.29
40B	63.5	39.37	38.1	22.89	8.0	8.5	52.96	52.96
48B	76.2	48.26	45.72	29.24	10.0	12.0	63.88	63.88

**32B - 48B Load Ratings Chart (mm)**

BS Chain No.	Pin Length					Transverse Pitch C	Average Tensile Strength kN	Tensile Strength min kN	Weight Per Metre kg/m	Ultimate Tensile Strength Q(ISO/DIN) min kN	Average Tensile Strength Q0 kN
	L max	Dc max	L1 max	L2 max	L3 max						
32B-1	67.40	71.40	33.70	37.70	75.10	58.55	278.20	250.00	10.34	250	51
32B-2	126.00	129.97	63.00	66.97	136.87		510.30	450.00	20.28	450	66.60
32B-3	184.50	188.50	92.25	96.25	195.40		771.20	670.00	30.18	670	98
40B-1	82.60	86.35	41.30	45.05	90.90	72.29	388.20	355.00	16.64	451	93
40B-2	154.90	158.67	77.45	81.22	165.57		718.60	630.00	32.54	902	123
40B-3	227.20	230.97	113.60	117.37	237.87		1100.00	950.00	48.68	1353	181
48B-1	99.10	107.0	49.55	57.45	110.5	91.21	628.50	560.00	25.10	677	129
48B-2	190.40	198.2	95.20	103.00	201.9		1136.00	1000.00	50.20	1353	171
48B-3	281.60	289.4	140.80	148.60	293.1		1716.00	1500.00	75.30	2030	252

The O-Ring chain includes rubber O-rings between link plates, enhancing lubrication and durability. It prevents contamination, reducing maintenance, improving performance and extending lifespan.

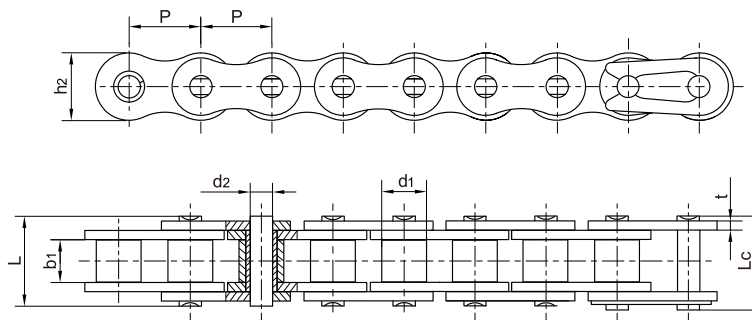

Chain No.	Pitch P mm	Roller Diameter d1 max mm	Width Between Inner Plates b1 min mm	Pin Diameter d2 mm	Pin Length		Plate Dimensions		Ultimate Tensile Strength Q min kN
					L mm	Lc mm	h2 mm	t/T mm	
40-0	12.7	7.92	7.85	3.96	19.55	20.65	12.0	1.5	13.8
50-0	15.875	10.16	9.40	5.08	23.30	24.5	15.0	2.03	21.8
60-0	19.05	11.91	12.57	5.94	28.65	30.5	18.0	2.42	31.1
80-0	25.40	15.88	15.75	7.92	35.85	39.0	24.0	3.25	55.6
100-0	31.75	19.05	18.95	9.53	43.2	47.00	30.00	4.0	110.20
120-0	38.10	22.23	25.22	11.11	54.00	57.5	35.70	4.80	158.20
08B1-0	12.7	7.92	7.85	3.96	17.8	19.1	11.8	1.6	18
10B1-0	10.16	7.4	9.4	5.08	20.8	22.4	14.7	1.7	22.4
12B1-0	19.05	12.07	11.68	5.72	23.6	25.3	16	1.85	29
16B1-0	25.4	15.88	17.02	8.28	38.1	40.6	21	3.1/4.1	60

## O-Ring with Straight Side Plates

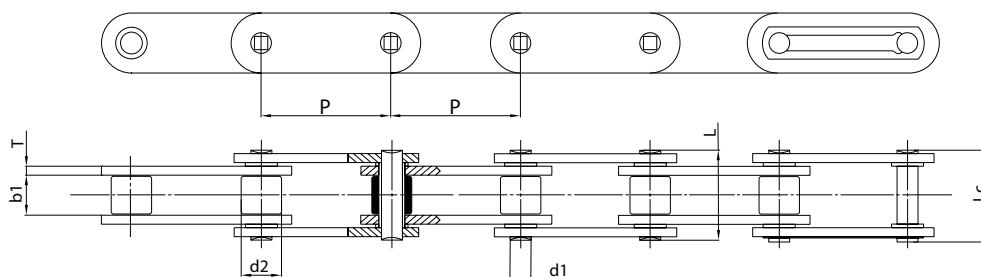

Chain No.	Pitch P mm	Roller Diameter d2 max mm	Width Between Inner Plates b1 min mm	Pin Diameter d1 max mm	Plates Thickness T mm	Inner Plate Depth h2 max mm	Pin Length		Ultimate Tensile Strength kN	Weight Per Metre kg/m
							L max mm	Lc max mm		
C2040-OR	25.40	7.920	7.85	3.96	1.5	12.00	18.30	19.60	17.80	0.60
C2050-OR	31.75	10.16	9.40	5.09	2.03	15.09	24.80	26.00	29.20	0.82
C2060-OR	38.10	11.91	12.57	5.94	2.42	18.08	30.40	31.90	41.60	1.17
C2080-OR	50.80	15.88	15.75	7.94	3.25	24.13	35.50	37.00	72.00	2.13
C2100-OR	63.50	19.05	18.95	9.53	4.00	30.00	43.2	47.00	110.20	3.10
C2120-OR	76.20	22.23	25.22	11.11	4.80	35.70	54.00	57.5	158.20	4.70

H Series roller chains differ from standard roller chains in the extra thickness of link plates. Thicker plates provide greater shock load resistance and increased fatigue strength.

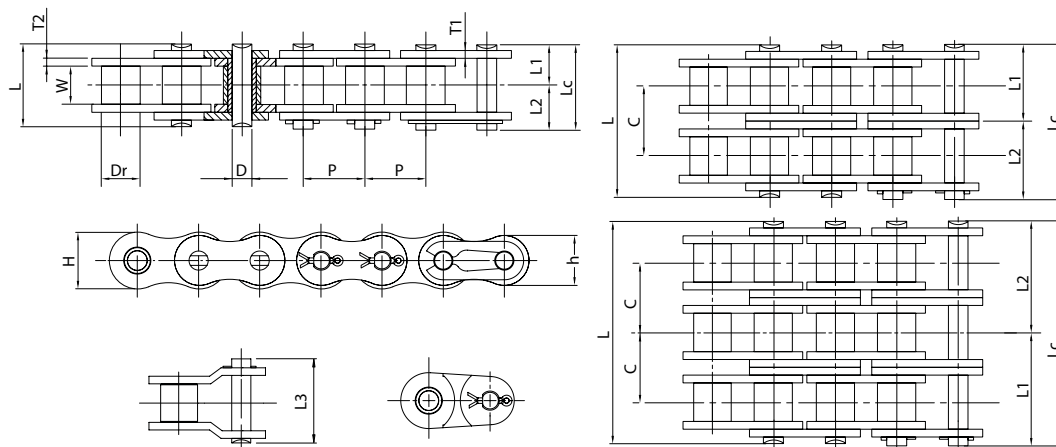

## 08AH/40H - 24AH/120H Size Chart (mm)

BS Chain No.	ANSI Chain No.	Pitch P	Roller Diameter Dr min	Width Between Inner Plates W min	Pin Diameter D min	Plate Thickness T min	Inner Plate Depth H min	Pin Length			Transverse Pitch C	Average Pitch kN	Ultimate Tensile Strength kN	Weight Per Metre kg/m
								L max	Lc max	L3 max				
08AH-1	40H	12.7	7.92	7.85	3.98	2.03	12.07	20.10	22.10	23.16	—	17.80	13.8	0.83
10AH-1	50H	15.875	10.16	9.40	5.09	2.42	15.09	23.36	25.36	26.42		29.20	21.8	1.27
12AH-1	60H-1	19.05	11.91	12.57	5.96	3.25	18.08	29.90	32.40	33.46		26.11	41.60	31.10
12AH-2	60H-2							56.00	58.50	59.56	83.20		62.30	3.75
12AH-3	60H-3							82.10	84.60	85.66	124.80		93.40	5.60
16AH-1	80H-1	25.4	15.88	15.75	7.94	4.0	24.13	36.60	39.60	41.60	32.59	72.0	55.60	3.16
16AH-2	80H-2							69.20	72.20	74.30		142.0	111.2	6.30
16AH-3	80H-3							101.80	104.80	106.90		216.0	166.8	9.40
20AH-1	100H-1	31.75	19.05	18.90	9.54	4.8	30.18	44.10	47.60	50.10	39.09	110.2	86.7	4.55
20AH-2	100H-2							83.20	86.70	89.30		220.4	173.5	9.10
20AH-3	100H-3							122.30	125.80	128.50		330.0	260.2	13.60
24AH-1	120H-1	38.10	22.23	25.22	11.11	5.6	36.20	53.80	58.8	62.05	48.87	157.2	124.60	6.68
24AH-2	120H-2							102.70	107.70	110.05		314.4	249.1	13.30
24AH-3	120H-3							151.50	156.50	159.95		417.6	373.7	20.00

H Series roller chains differ from standard roller chains in the extra thickness of link plates. Thicker plates provide greater shock load resistance and increased fatigue strength.

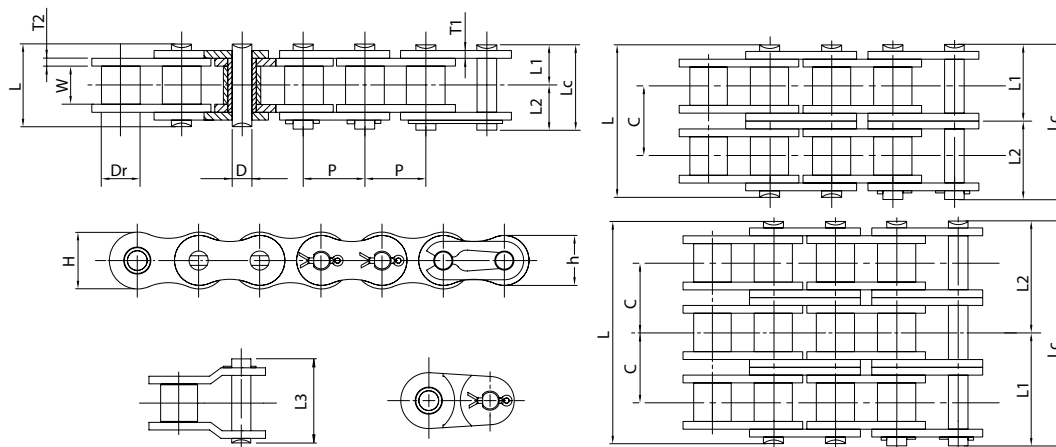

## 28AH/140H - 48AH/240H Size Chart (mm)

BS Chain No.	ANSI Chain No.	Pitch P	Roller Diameter Dr min	Width Between Inner Plates W min	Pin Diameter D min	Plate Thickness T min	Inner Plate Depth H min	Pin Length			Transverse Pitch C	Average Pitch kN	Ultimate Tensile Strength kN	Weight Per Metre kg/m
								L max	Lc max	L3 max				
28AH-1	140H-1	44.45	25.40	25.22	12.71	6.4	42.24	57.90	63.40	66.65	52.20	210.00	169.0	8.36
28AH-2	140H-2							110.10	115.60	118.95		420.00	338.1	16.70
28AH-3	140H-3							162.30	167.80	171.25		630.0	507.1	25.00
32AH-1	160H-1	50.80	28.58	31.55	14.29	7.15	48.26	68.50	74.50	78.5	61.90	275.0	222.4	10.36
32AH-2	160H-2							130.40	136.40	140.50		550.0	444.8	20.70
32AH-3	160H-3							192.3	198.30	202.50		825.0	667.2	31.00
36AH-1	180H-1	57.15	35.71	35.48	17.46	8.0	54.3	76.70	81.00	84.00	69.16	360.0	281.0	14.80
36AH-2	180H-2							146.0	149.0	152.0		720.0	562.0	29.60
36AH-3	180H-3							216.0	218.0	221.0		1067.0	834.0	44.40
40AH-1	200H-1	63.50	39.68	37.85	19.85	9.50	60.33	90.70	97.70	102.50	78.31	456.0	347.0	19.18
40AH-2	200H-2							169.00	176.00	180.90		912.0	693.9	38.30
40AH-3	200H-3							250.30	257.30	262.30		1368.0	1040.9	57.80
48AH-1	240H-1	76.2	47.63	47.36	23.81	12.80	72.39	109.0	116.0	119.0	101.2	640.0	500.0	28.29
48AH-2	240H-2							211.0	217.0	220.0		1280.0	1000.0	56.58
48AH-3BS	240H-3							312.0	319.0	322.0		1920.0	1500.0	84.87

# Super Heavy Series SH

SH series roller chains have a greater ultimate tensile strength (up to 25% -35%) over ANSI standard roller chains by using thicker side plates and through hardened pins. SH chains also provide a greater shock load resistance and are suited to slower speed high torque applications. The dimensions of the chain are identical to ANSI heavy series standard roller chains.

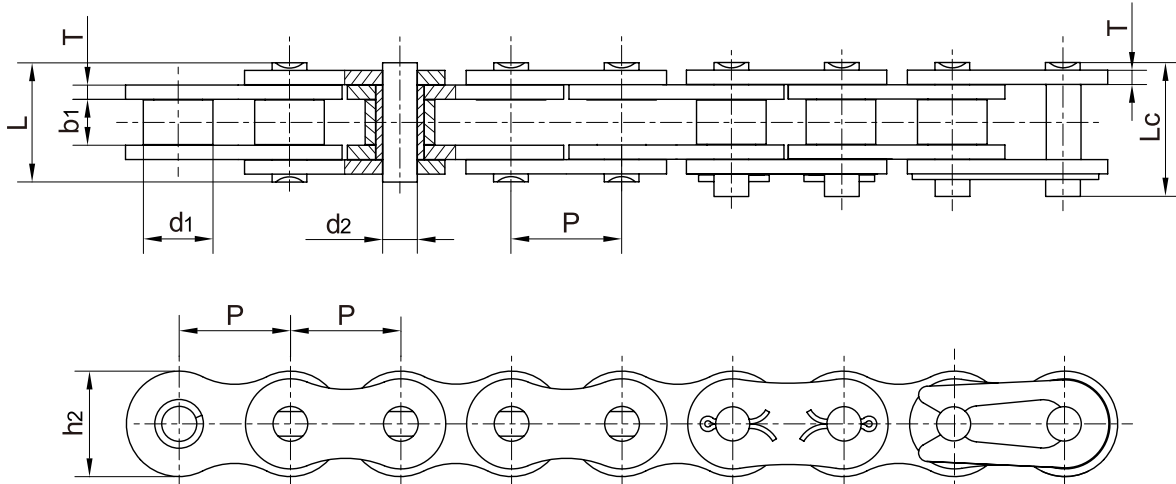

ANSI Chain No.	Pitch P mm	Roller Diameter d1 max mm	Width Between Inner Plates b1 min mm	Pin Diameter d2 max mm	Pin Length		Inner Plate Depth h2 max mm	Plate Thickness t/T max mm	Ultimate Tensile Strength Q (ISO/DIN) min kN	Average Tensile Strength Q0 kN	Weight Per Metre q = kg/m
					L max mm	Lc max mm					
40SH	12.70	7.95	7.85	3.96	18.8	19.9	12.00	2.03	22.4	24.8	0.82
50SH	15.88	10.16	9.40	5.08	22.1	23.4	15.09	2.42	30.4	36.2	1.25
60SH	19.05	11.91	12.57	5.94	29.2	31.6	18.00	3.25	44.1	50.4	1.87
80SH	25.40	15.88	15.75	7.92	36.2	37.7	24.00	4.00	88.2	93.0	3.10
100SH	31.75	19.05	18.90	9.53	43.6	46.9	30.00	4.80	116.6	129.1	4.52
120SH	38.10	22.23	25.22	11.10	53.5	57.5	35.70	5.60	158.2	175.3	6.60
140SH	44.45	25.40	25.22	12.70	57.6	62.2	41.00	6.40	206.0	266.5	8.30
160SH	50.80	28.58	31.55	14.27	68.2	73.0	47.80	7.20	274.0	293.0	10.30
200SH	63.50	39.68	37.85	19.85	86.6	93.5	60.00	9.50	506.1	562.30	19.16

\*Bush chain: d1 indicates the external diameter of the bushing.

Stainless steel chains are suitable for operation in an environment requiring high thermal resistance (-200C to 4000C), corrosion resistance and cleanliness. They can be also fitted with attachments for conveyor purposes.

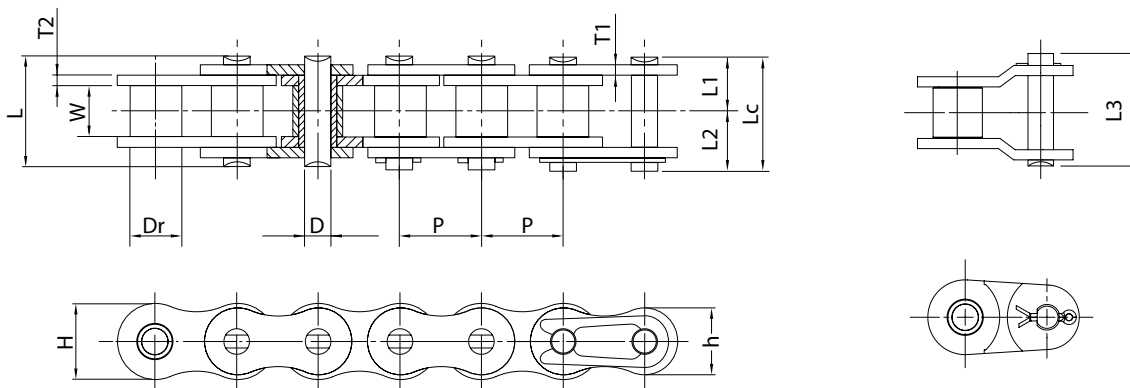

Chain No.	Pitch P mm	Roller Diameter d1 max mm	Width Between Inner Plates b1 min mm	Pin Diameter d2 max mm	Pin Length		Inner Plate Depth h2 max mm	Plate Thickness t/T mm	Ultimate Tensile Strength Q (ISO/DIN) min mm	Average Tensile Strength Q0 mm	Weight per Meter q = mm
					L max mm	Lc max mm					
*35SS	9.53	5.08	4.77	3.58	12.40	13.17	9.00	1.30	5.50	6.60	0.33
40SS	12.70	7.95	7.85	3.96	16.60	17.80	12.20	1.50	9.70	11.60	0.63
50SS	15.88	10.16	9.40	5.08	20.70	22.2	15.09	2.06	15.30	18.50	1.03
60SS	19.05	11.91	12.57	5.94	25.9	27.70	18.00	2.44	21.80	26.40	1.51
80SS	25.40	15.88	15.75	7.92	32.7	35.00	24.00	3.26	38.90	46.60	2.62
100SS	31.75	19.05	18.90	9.53	40.40	44.70	30.00	4.00	59.00	70.20	3.94
#06BSS	9.53	6.35	5.72	3.28	13.15	14.10	8.20	1.30	6.20	7.30	0.41
08BSS	12.70	8.51	7.75	4.45	16.70	18.20	11.80	1.60	12.00	14.30	0.70
10BSS	15.88	10.16	9.65	5.08	19.50	20.90	14.70	1.70	14.50	17.20	0.94
12BSS	19.05	12.07	11.68	5.72	22.50	24.20	16.00	1.85	18.50	22.00	1.16
16BSS	25.40	15.88	17.02	8.28	36.10	37.40	21.00	4.15/3.10	40.00	47.60	2.13
20BSS	31.75	19.05	19.56	10.19	41.30	45.00	26.40	4.50/3.50	59.00	69.60	3.73

\*Bushing chain: d1 in the table indicates the external diameter of the bushing.

#Straight side plates

# Small Size Conveyor Chain

Small Conveyor Chain consists of two main types: single pitch chains also called “General application chains,” and double pitch chains. Small Conveyor Chain can be customised for specific applications with various top rollers, side rollers, and attachments, in addition to the base chains.

## Our range

- ▶ Straight Side Plates Chain
- ▶ Hollow Pin Chain
- ▶ Double Pitch Chain
- ▶ Attachments
- ▶ Accumulation Chain
- ▶ Side Roller Chain
- ▶ Freeflow Chain
- ▶ Side Bow Chain





# Straight Side Plates

Also called chains with straight sidebars, these chains provide increased durability, efficient power transmission, ease of maintenance, and adaptability to different applications. If you need Ultra-high strength chain, please contact the sales department.

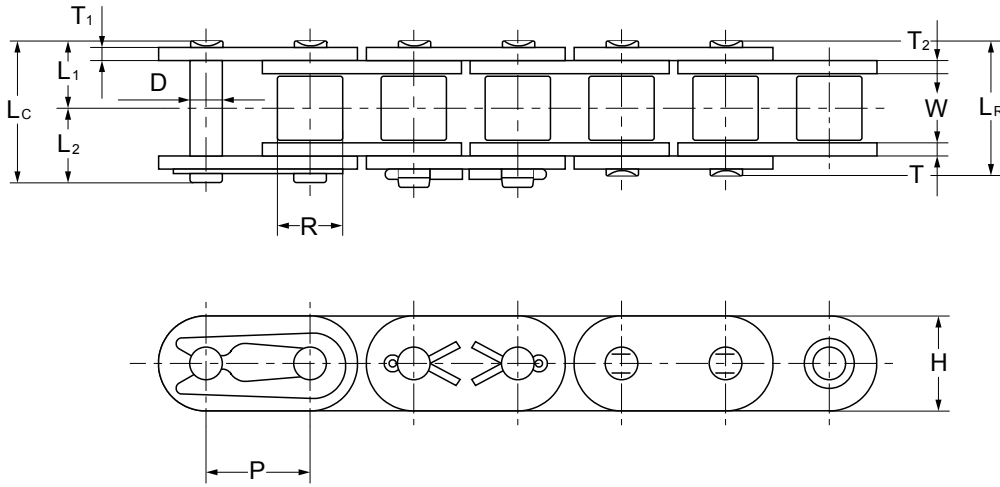

ANSI Chain No.	Pitch P	Dimensions (mm)									Average Ultimate Strength kN	Maximum Allowable Load kN	Average Chain Weight kg/m	Type of Connecting Link
		Roller		Pin			Plate		Height H	Thickness T				
		Diameter W	Diameter R	Diameter D	Length LR	Length LC	L1	L2						
35F	9.525	4.78	5.08	3.58	12.0	12.9	6.0	6.9	9.0	1.25	10.8	2.23	0.38	Spcl
40F	12.70	7.95	7.92	3.96	16.5	17.7	8.3	9.4	11.7	1.5	19.1	3.82	0.67	
50F	15.875	9.53	10.16	5.08	20.4	21.9	10.2	11.7	14.6	2.0	31.9	6.57	1.1	
60F	19.05	12.70	11.91	5.95	25.5	26.9	12.8	14.1	17.5	2.4	43.1	9.12	1.63	
80F	25.4	15.88	15.88	7.93	32.8	35.0	16.4	18.6	23.4	3.2	78.5	15.2	2.82	C
100F	31.75	19.05	19.05	9.53	39.4	43.0	19.7	23.3	29.3	4.0	118	23.5	4.37	
120F	38.10	25.40	22.23	11.1	49.5	53.4	24.8	28.6	35.1	4.8	167	31.4	6.45	
140F	44.45	25.40	25.40	12.7	54.0	58.3	27.0	31.3	40.9	5.6	216	42.2	8.29	
160F	50.80	31.75	28.58	14.28	64.3	68.7	32.2	36.5	46.7	6.4	275	54.9	10.96	
200F	63.50	38.1	39.67	19.83	78.5	87.0	39.3	47.7	59.8	8.0	451	73.9	18.96	
240F	76.20	47.63	47.63	23.78	96.4	104.1	48.2	55.9	70.3	9.5	677	101	26.47	

# Straight Side Plates

Also called chains with straight sidebars, these chains provide increased durability, efficient power transmission, ease of maintenance, and adaptability to different applications. If you need Ultra-high strength chain, please contact the sales department.

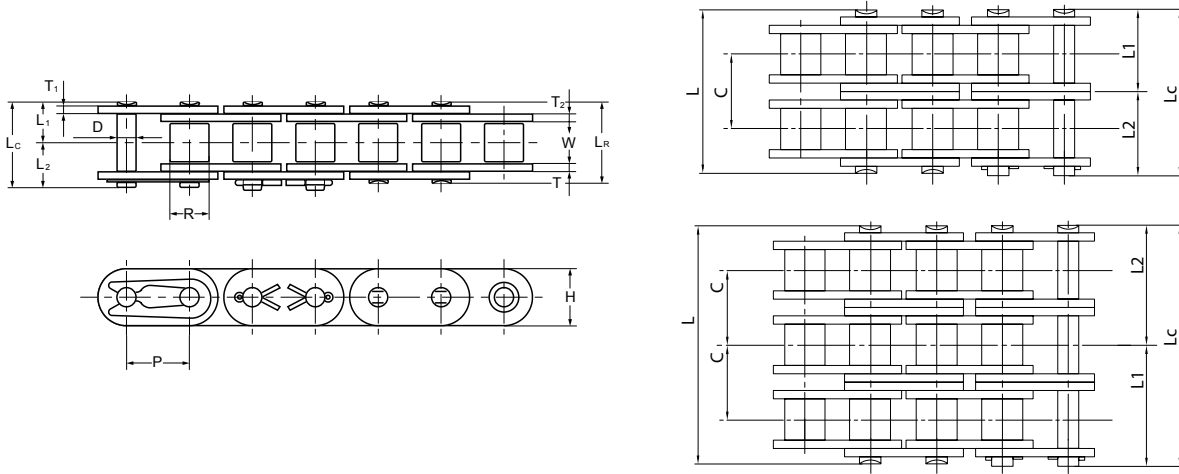

BS Chain No.	Pitch P mm	Roller Diameter R min mm	Width Between Inner Plates W min mm	Pin D min mm	Plate Thickness		Plate Depth H min mm	Pin Length			Transverse Pitch C mm	Tensile Strength		Weight Per Metre kg/m
					T1 mm	T2 mm		L max mm	Lc max mm	Lc max mm		Average kN	Ultimate kN	
C08B-1	12.70	8.51	7.75	4.45	1.6	1.6	11.81	17.00	18.50	18.50	13.92	18.60	17.80	0.86
C08B-2								31.00	32.50	33.80		35.00	31.10	1.66
C08B-3								44.90	46.40	47.80		48.80	44.50	2.46
C10B-1	15.875	10.16	9.65	5.08	1.7	1.7	14.73	19.60	21.05	21.35	16.59	25.60	22.20	1.20
C10B-2								36.20	37.65	39.65		50.20	44.50	2.34
C10B-3								52.80	54.20	56.30		75.80	66.70	3.60
C12B-1	19.05	12.07	11.68	5.72	1.85	1.85	16.13	22.70	24.35	25.05	19.46	30.30	28.90	1.46
C12B-2								42.20	43.80	46.50		60.30	57.80	2.93
C12B-3								61.70	63.30	66.20		91.00	86.70	4.45
C16B-1	25.4	15.88	17.02	8.28	3.10	4.15	21.08	36.10	37.95	39.05	31.88	68.80	60.0	3.10
C16B-2								68.00	69.90	73.90		136.00	106.0	6.22
C16B-3								99.90	101.80	106.00		205.60	160.0	9.20
C20B-1	31.75	19.05	19.56	10.19	3.7	4.6	26.42	43.20	44.67	48.57	36.45	108.60	95.00	4.56
C20B-2								79.70	81.07	86.57		208.40	170.00	9.06
C20B-3								116.10	117.40	123.15		285.30	250.00	13.50
C24B-1	38.1	25.40	25.40	14.63	5.2	6.0	33.4	53.40	58.20	62.30	48.36	176.80	160.00	8.63
C24B-2								101.80	106.65	112.95		322.60	280.00	16.84
C24B-3								150.20	155.20	161.50		489.50	425.00	25.00
C28B-1	44.45	27.94	30.99	15.90	6.3	7.5	37.08	65.10	70.00	74.60	59.56	223.60	200.00	10.96
C28B-2								124.70	129.57	136.97		407.50	360.00	21.60
C28B-3								184.30	189.17	196.57		610.00	530.00	32.39
C32B-1	50.8	29.21	30.99	17.81	6.3	7.0	42.29	67.40	71.40	75.10	58.55	278.20	250.00	11.81
C32B-2								126.00	129.97	136.87		510.30	450.00	23.16
C32B-3								184.50	188.50	195.40		771.20	670.00	34.46

# Double Pitch Drive Chain

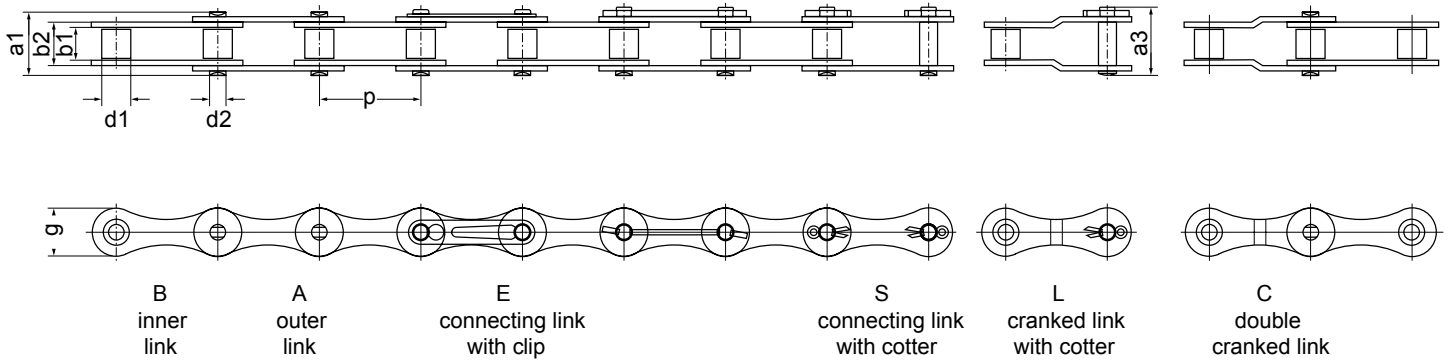

ISO Chain No.	ANSI Chain No.	Pitch P mm	Width Between Inner Plates $b_1$ min mm	Roller Diameter $d_1$ max mm	Pin Diameter $d_2$ max mm	Pin Length		Plate Depth $g$ max mm	Plate Thickness		Tensile Strength		Weight Per Metre kg/m
						$a_1$ max mm	$a_3$ max mm		T1 max mm	T2 max mm	Ultimate min kN	Average kN	
208A	2040	25.40	7.85	7.92	3.98	17.80	19.80	12.07	1.50	1.50	13.80	17.80	0.45
210A	2050	31.75	9.40	10.16	5.09	21.80	23.80	15.09	2.03	2.03	21.80	29.20	0.75
212A	2060	38.10	12.57	11.91	5.96	26.90	29.40	18.08	2.42	2.42	31.10	41.60	1.05
216A	2080	50.80	15.75	15.88	7.94	33.50	36.50	24.13	3.25	3.25	55.60	72.00	1.75
220A	2100	63.50	18.90	19.05	9.54	41.10	44.60	30.18	4.00	4.00	86.70	110.20	2.60
224A	2120	76.20	25.22	22.23	11.11	50.80	54.80	36.20	4.80	4.80	124.60	157.20	4.10
208B	—	25.40	7.75	8.51	4.45	17.00	19.00	11.81	1.60	1.60	17.80	18.60	0.48
210B	—	31.75	9.65	10.16	5.08	19.60	21.60	14.73	1.70	1.70	22.20	25.60	0.68
212B	—	38.10	11.68	12.07	5.72	22.70	25.20	16.13	1.85	1.85	28.90	30.30	0.79
216B	—	50.80	17.02	15.88	8.28	36.10	39.10	21.08	3.10	4.15	60.00	68.60	1.80
220B	—	63.50	19.56	19.05	10.19	43.20	46.70	26.42	3.70	4.60	95.00	108.60	2.65
224B	—	76.20	25.40	25.40	14.63	53.40	58.40	33.40	5.20	6.00	160.00	176.80	4.75
228B	—	88.90	30.99	27.94	15.90	65.10	70.60	37.08	6.30	7.50	200.00	223.00	6.25
232B	—	101.60	30.99	29.21	17.81	67.40	73.40	42.29	6.30	7.00	250.00	278.00	6.75

# Double Pitch Conveyor Chain

These chains utilise straight link plates and are categorised into two series based on the outer diameter of rollers: the small roller series and the large roller series. The H represents thicker plates.

## Small Roller Series - S Type

- ▶ Identified by a "0" as the final digit of the chain number.
- ▶ The outer diameter of the roller matches that of the standard roller chain it is derived from. E.g.: The outer roller diameter of the C2040 corresponds to the No.40 standard roller chain.
- ▶ Standard sprockets with a minimum of 30 teeth can be utilised. E.g.: The C2040 32-tooth sprocket (16 working teeth) can be used in conjunction with the No.40 32-tooth standard sprocket.

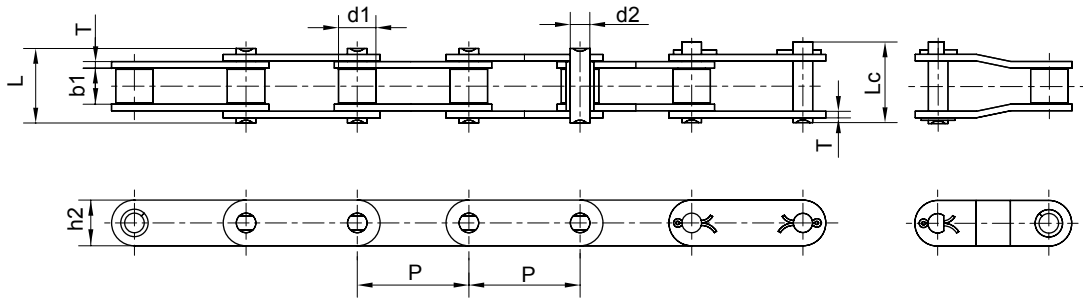

ANSI Chain No.	Pitch P mm	Roller Diameter d <sup>1</sup> max mm	Width Between Inner Plates b <sup>1</sup> min mm	Pin Diameter d <sup>2</sup> max mm	Pin Length		Inner Plate Depth t/T mm	Plate Thickness t/T mm	Tensile Strength		Weight Per Metre kg/m
					L max mm	Lc max mm			Ultimate Q(ISO/DIN) min mm	Average Q0 mm	
C2040	25.40	7.95	7.85	3.96	17.80	21.70	12.07	1.50	14.10	17.80	0.50
C2050	31.75	10.16	9.40	5.08	21.80	25.90	15.09	2.06	22.20	28.00	0.73
C2060H	38.10	11.91	12.57	5.94	29.90	34.50	18.08	3.26	31.80	39.00	1.44
C2080H	50.80	15.88	15.75	7.92	36.60	42.00	24.13	4.00	56.70	71.50	2.54
C2100H	63.50	19.05	18.90	9.53	44.10	50.20	30.18	4.80	88.50	102.00	3.56
C2120H	76.20	22.23	25.22	11.10	53.50	57.50	35.70	5.65	127.00	156.90	5.26
C2160H	101.60	28.58	31.75	14.27	68.20	73.00	47.80	7.25	226.80	269.70	9.06

# Double Pitch Conveyor Chain

These chains utilise straight link plates and are categorised into two series based on the outer diameter of rollers: the small roller series and the large roller series. The H represents thicker plates.

## Large Roller Series - R Type

- ▶ Identified by a "2" as the final digit of the chain number.
- ▶ The outer diameter of the roller matches that of the standard roller chain, which shares the same pitch as the double pitch roller chain,  
e.g.: The roller outer diameter of the C2042 corresponds to the No.80 standard roller chain since they both have a chain pitch of 25.4mm  
(the roller outer diameter is 15.88mm).
- ▶ Specialised sprockets must be used.

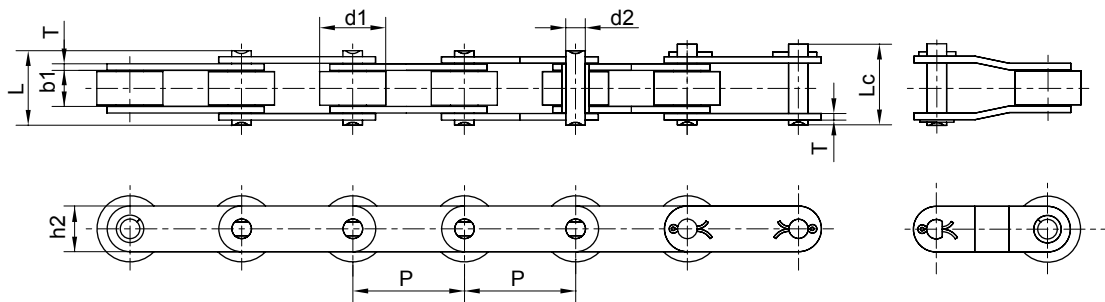

ANSI Chain No.	Pitch P mm	Roller Diameter $d_1$ max mm	Width Between Inner Plates $b_1$ min mm	Pin Diameter $d_2$ max mm	Pin Length		Inner Plate Depth $t/T$ mm	Plate Thickness $t/T$ mm	Tensile Strength		Weight Per Metre kg/m
					L max mm	Lc max mm			Ultimate Q(ISO/DIN) min mm	Average Q0 mm	
C2042	25.40	15.88	7.85	3.96	17.80	21.70	12.07	1.50	14.10	17.80	0.84
C2052	31.75	19.05	9.40	5.08	21.80	25.90	15.09	2.06	22.20	28.00	1.27
C2062H	38.10	22.23	12.57	5.94	29.90	34.50	18.08	3.26	31.80	39.00	2.07
C2082H	50.80	28.58	15.75	7.92	36.60	42.00	24.13	4.00	56.70	71.50	3.58
C2102H	63.50	39.67	18.90	9.53	44.10	50.20	30.18	4.80	88.50	102.00	5.38
C2122H	76.20	44.45	25.22	11.10	53.50	57.50	35.70	5.65	127.00	156.90	8.26
C2162H	101.60	57.15	31.75	14.27	68.20	73.00	47.80	7.25	226.80	269.70	12.77

**ANSI Standard**

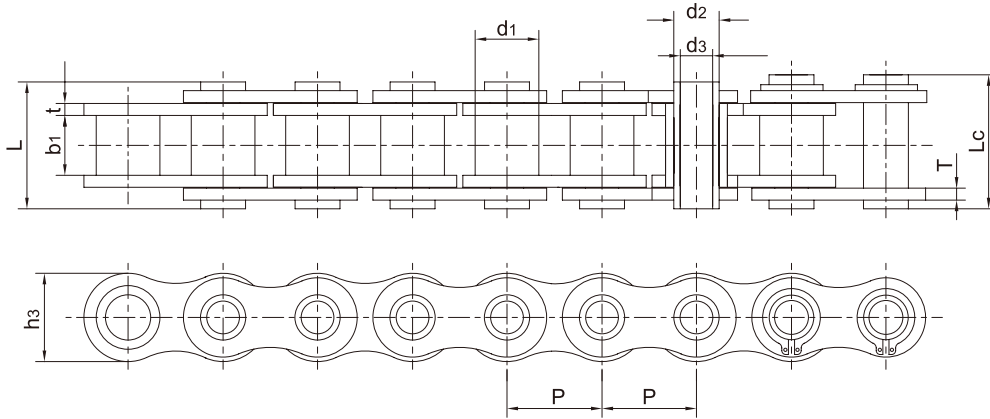

ANSI Chain No.	Pitch P mm	Roller Diameter d min mm	Width Between Inner Plates W max mm	Pin Diameter		Pin Length		Plate Thickness			Ultimate Tensile Strength min kN	Weight Per Metre kg/m
				d1 max mm	d2 min mm	L max mm	Lc max mm	H max mm	T1 max mm	T2 max mm		
40HP	12.70	7.94	7.85	5.68	4.00	16.0	17.50	12.07	1.5	1.5	11.0	0.55
50HP	15.875	10.16	9.40	7.22	5.12	20.1	21.70	15.09	2.03	2.03	20.0	0.90
60HP	19.05	11.91	12.57	8.38	5.99	25.1	26.80	18.08	2.42	2.42	26.0	1.30
80HP	25.40	15.88	15.75	11.375	8.02	32.5	34.05	24.13	3.25	3.25	48.0	2.28

**ANSI Hollow Pin with Straight Side Plates**

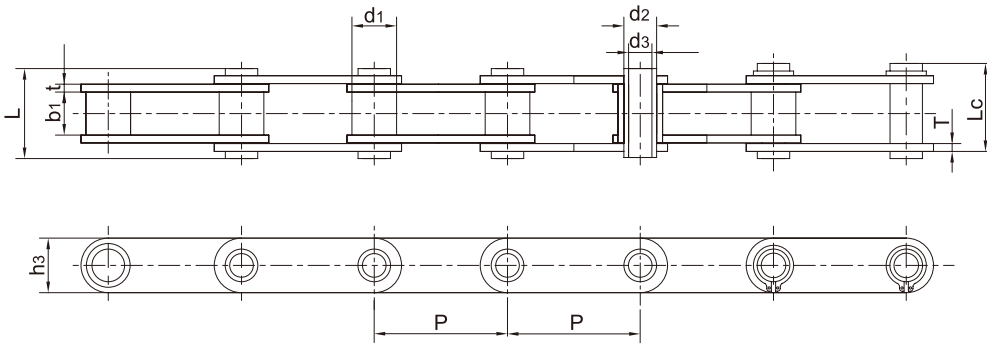

ANSI Chain No.	Pitch P mm	Roller Diameter d min mm	Width Between Inner Plates W max mm	Pin Diameter		Pin Length		Plate Thickness			Ultimate Tensile Strength min kN	Weight Per Metre kg/m
				d1 max mm	d2 min mm	L max mm	Lc max mm	H max mm	T1 max mm	T2 max mm		
C40HP	12.70	7.94	7.85	5.68	4.00	16.0	17.50	12.07	1.5	1.5	11.0	0.50
C50HP	15.875	10.16	9.40	7.22	5.12	20.1	21.70	15.09	2.03	2.03	20.0	0.85
C60HP	19.05	11.91	12.57	8.38	5.99	25.1	26.80	18.08	2.42	2.42	26.0	1.25
C80HP	25.40	15.88	15.75	11.375	8.02	32.5	34.05	24.13	3.25	3.25	48.0	2.23

## BS Standard

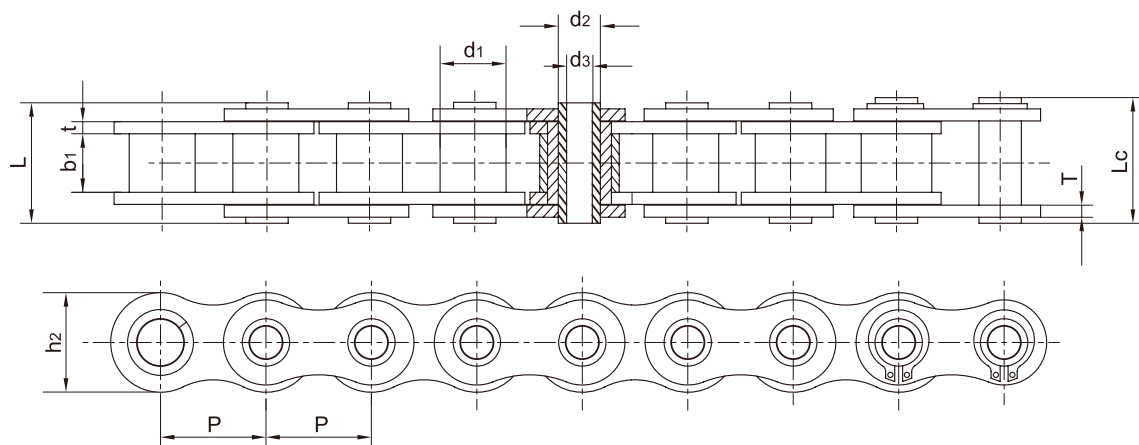

BS Chain No.	Pitch P mm	Bush Diameter d1 max mm	Width Between Inner Plates b1 max mm	Pin Diameter		Pin Length		Inner Plate Depth h2 max mm	Plate Thickness t/T max mm	Tensile Strength		Weight Per Metre q kN	Type
				d2 max mm	d3 max mm	L max mm	Lc max mm			Ultimate Q max kN	Average Q0 max kN		
08BHP	12.700	8.510	7.75	6.37	4.00	16.7	18.0	11.8	1.6	11.00	12.4	0.61	A
10BHB	15.875	10.16	9.65	5.94	4.04	19.3	20.6	14.7	1.70	17.00	20.8	0.86	A
12BHB	19.050	12.07	11.68	6.50	4.00	21.6	22.8	15.9	1.85	23.60	25.9	1.09	A
16BHB	25.400	15.88	12.70	9.53	7.05	30.8	32.2	23.0	4.15/3.1	40.00	45.0	2.28	A

# Double Pitch Hollow Pin Chain

## Straight Side Plates (Large Roller)

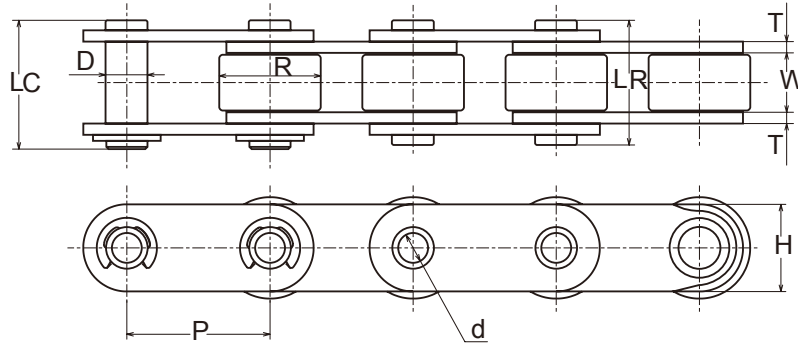

ANSI Chain No.	Pitch P mm	Roller Diameter W min mm	Width Between Inner Plates		Pin Diameter		Pin Length		Plate Thickness		Ultimate Tensile Strength min kN	Weight Per Metre kg/m
			R max mm	D max mm	d min mm	LR max mm	LC max mm	H max mm	T max mm			
C2040HP	25.4	7.94	7.85	5.68	4.00	16.0	17.5	12.07	1.5	11.0	0.48	
C2050HP	31.75	10.16	9.4	7.22	5.12	20.1	21.7	15.09	2.03	20.0	0.77	
C2060HP	38.10	11.91	12.57	8.38	5.99	25.1	26.8	18.08	2.42	26.0	1.10	
C2080HP	50.80	15.88	15.75	11.37	8.02	32.5	34.1	24.13	3.25	48.0	1.85	

## R-type (Large Roller)

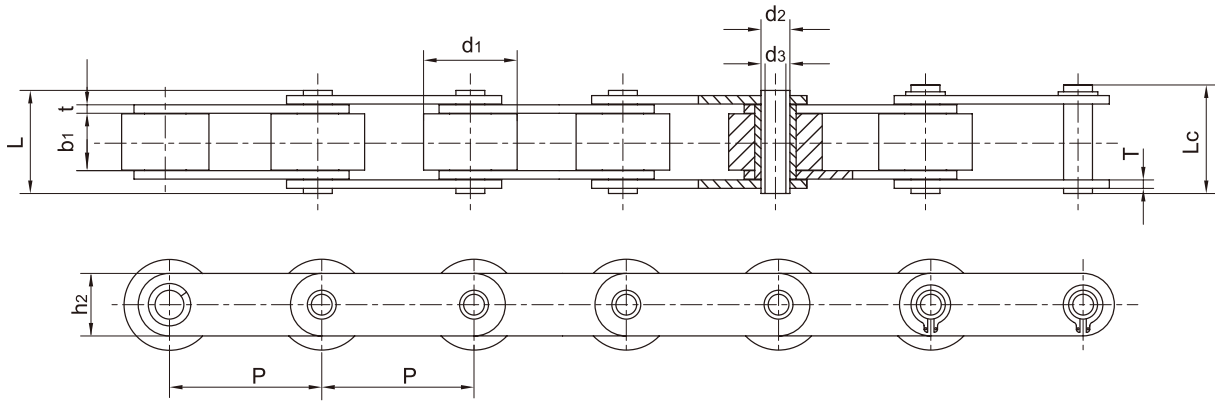

ANSI Chain No.	Pitch P mm	Bush Diameter d1 max mm	Width Between Inner Plates b1 max mm	Pin Diameter		Pin Length		Inner Plate Depth h2 max mm	Plate Thickness t/T max mm	Tensile Strength		Weight Per Metre q kN
				d2 max mm	d3 max mm	L max mm	Lc max mm			Ultimate Q max kN	Average Q0 max kN	
C2042HP	25.40	15.88	7.85	5.63	4.00	16.5	17.6	12.0	1.50	11.0	12.6	0.78
C2052HP	31.75	19.05	9.53	7.22	5.12	20.5	21.8	15.0	2.03	20.4	22.8	1.25
C2062HP	38.10	22.23	12.70	8.33	6.00	25.9	26.8	18.0	2.42	24.0	27.1	1.72
C2082HP	50.80	28.58	15.75	11.40	8.05	32.4	33.8	24.0	3.25	50.0	55.2	2.82
C2052HPF1	31.75	19.05	9.40	7.03	5.12	20.0	21.5	15.3	1.85	15.0	17.3	1.21
C2042H-HP	25.40	15.88	7.85	5.63	4.00	18.8	19.9	12.0	2.03	11.0	13.2	0.95
C2052H-HP	31.75	19.05	9.53	7.22	5.12	22.1	23.4	15.0	2.42	20.4	23.5	1.44
C2062H-HP	38.10	22.23	12.70	8.33	6.00	29.2	30.2	17.0	3.25	24.0	27.6	1.99
C2082H-HP	50.80	28.58	15.75	11.40	8.05	36.2	37.6	24.0	4.00	50.0	56.5	3.26



# Single Pitch Attachments

## A-1

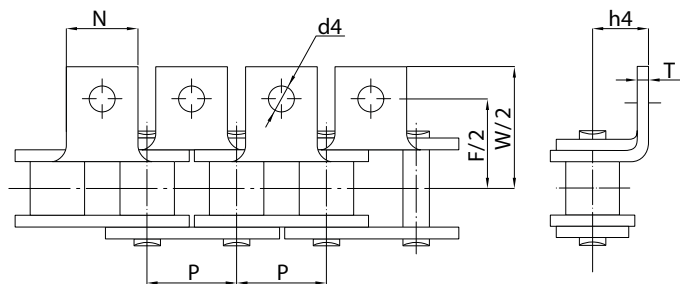

## K-1

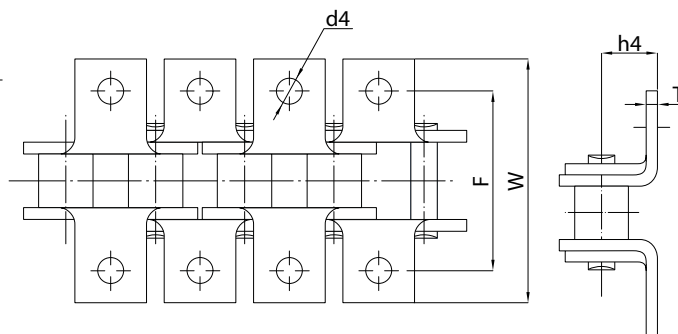

BS Chain No.	ANSI Chain No.	P mm	N mm	F mm	W mm	T mm	h4 mm	d4 mm
04C	25	6.350	5.6	13.80	23.2	0.80	4.30	3.4
06C	35	9.525	7.9	19.00	28.6	1.30	6.35	3.4
08A	40	12.700	9.5	25.40	35.2	1.50	7.90	3.4
085	41	12.700	9.5	24.00	33.4	1.30	6.90	3.6
10A	50	15.875	12.7	31.75	46.2	2.03	10.30	5.5
12A	60	19.050	15.9	38.10	55.6	2.42	11.90	5.5
16A	80	25.400	19.1	50.80	64.8	3.25	15.90	6.8
20A	100	31.750	25.4	63.50	89.8	4.00	19.80	9.2
24A	120	38.100	28.6	76.20	108.5	4.80	23.00	9.8
28A	140	44.450	34.9	88.90	123.0	5.60	28.60	11.4
32A	160	50.800	38.1	101.60	142.8	6.40	31.75	13.1
40A	200	63.500	50.8	127.00	179.0	8.00	42.88	16.3
*06B	—	9.525	8.0	19.04	27.0	1.30	6.50	3.5
08B	—	12.700	9.5	25.40	36.4	1.60	8.90	4.5
10B	—	15.875	14.3	31.75	44.6	1.70	10.31	5.3
12B	—	15.875	16.0	38.10	52.4	1.85	13.46	6.4
16B	—	15.875	19.1	50.80	72.6	3.10	15.88	6.4
20B	—	15.875	35.0	63.50	100.5	3.50	19.80	9.0
24B	—	15.875	30.0	76.20	108.4	4.80	26.67	10.5
28B	—	15.875	35.0	88.90	123.0	6.00	28.58	13.1
32B	—	50.800	38.1	101.60	142.8	6.00	31.75	13.1

\*Straight plate chain.

# Single Pitch Attachments

## SA-1/M35 (One Side)

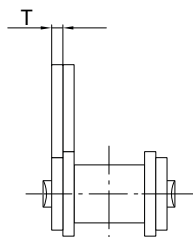
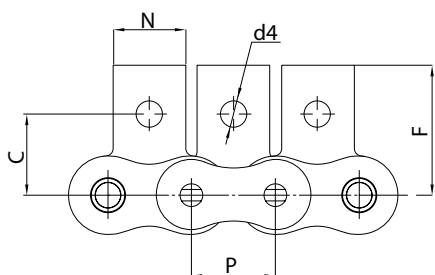

## SK-1/M1 (Both Sides)

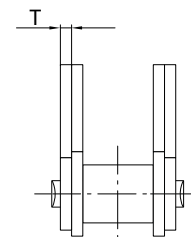
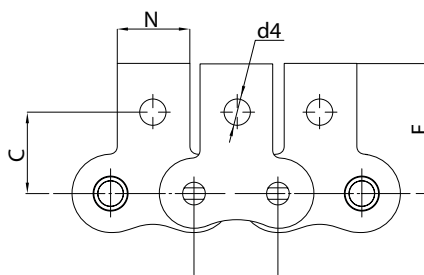

BS Chain No.	ANSI Chain No.	P mm	N mm	C mm	F mm	T mm	h4 mm
04C	25	6.350	5.6	7.95	11.7	0.80	3.4
06C	35	9.525	7.9	9.50	14.55	1.30	3.4
08A	40	12.700	9.5	12.70	19.05	1.50	3.4
08S	41	12.700	9.5	11.85	16.55	1.30	3.6
10A	50	15.875	12.7	15.90	25.25	2.03	5.5
12A	60	19.050	15.9	18.30	29.33	2.42	5.5
16A	80	25.400	19.1	24.60	34.70	3.25	6.8
20A	100	31.750	25.4	31.80	43.30	4.00	9.2
24A	120	38.100	28.6	36.50	51.60	4.80	9.8
28A	140	44.450	34.9	44.50	62.00	5.60	11.4
32A	160	50.800	38.1	50.80	69.85	6.40	13.1
40A	200	63.500	50.8	63.50	88.90	8.00	16.3
*06B	—	9.525	8.0	9.52	13.50	1.30	3.5
08B	—	12.700	9.5	13.35	18.90	1.60	4.3
10B	—	15.875	14.3	16.50	22.95	1.70	5.3
12B	—	19.050	16.0	21.45	28.60	1.85	6.4
16B	—	25.400	19.1	23.15	34.00	3.10	6.4
20B	—	31.750	35.0	30.50	45.70	3.50	9.0
24B	—	38.100	30.0	36.00	61.50	4.80	10.5

\*Straight plate chain.

### AA-1

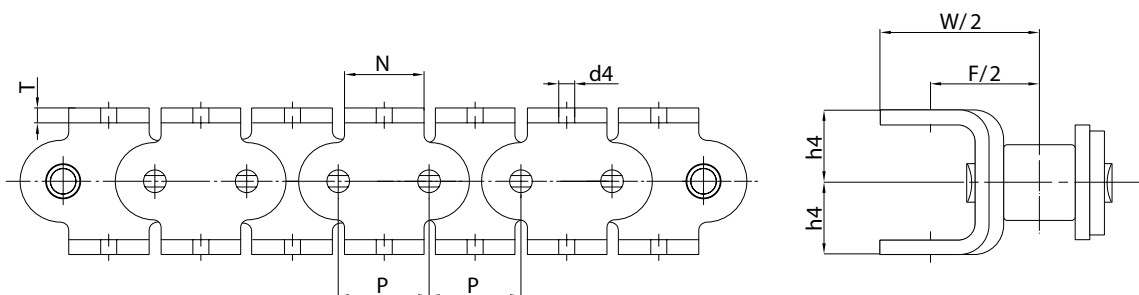

### KK-1

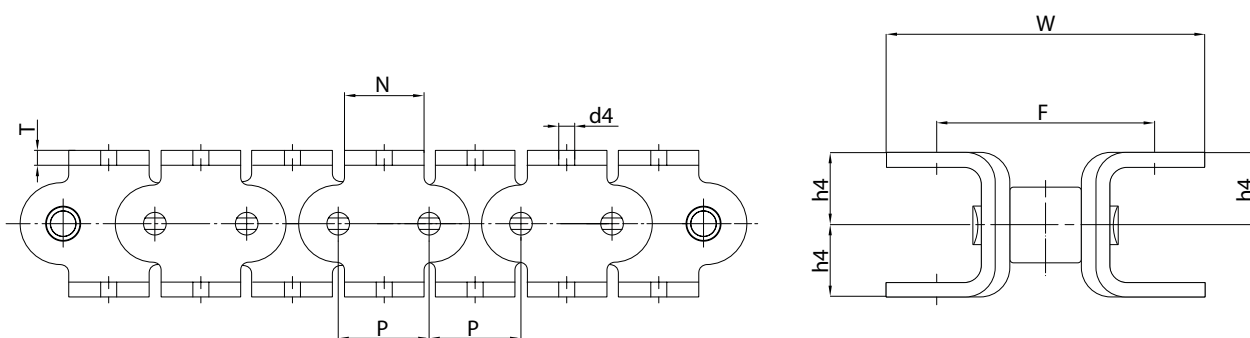

BS Chain No.	ANSI Chain No.	P mm	N mm	F mm	W mm	T mm	h4 mm	d4 mm
08A	40	12.700	9.5	25.40	35.2	1.50	7.90	3.4
10A	50	15.875	12.7	31.75	46.2	2.03	10.30	5.5
12A	60	19.050	15.9	38.10	55.6	2.42	11.90	5.5
16A	80	25.400	19.1	50.80	64.8	3.25	15.90	6.8
20A	100	31.750	25.4	63.50	87.3	4.00	19.80	9.2
24A	120	38.100	28.6	76.20	108.5	4.80	23.00	9.8
*06B	—	9.525	8.0	19.04	27.0	1.30	6.50	3.5
08B	—	12.700	9.5	25.40	36.4	1.60	8.90	4.5
10B	—	15.875	14.3	31.75	44.6	1.70	10.31	5.3
12B	—	19.050	16.0	38.10	52.4	1.85	13.46	6.4
16B	—	25.400	19.1	50.80	72.6	3.10	15.88	6.4
20B	—	31.750	35.0	63.50	100.5	3.50	19.80	9.0
24B	—	38.100	30.0	76.20	108.4	4.80	26.67	10.5

\*Straight plate chain.

# Single Pitch Attachments

**SAA-1**

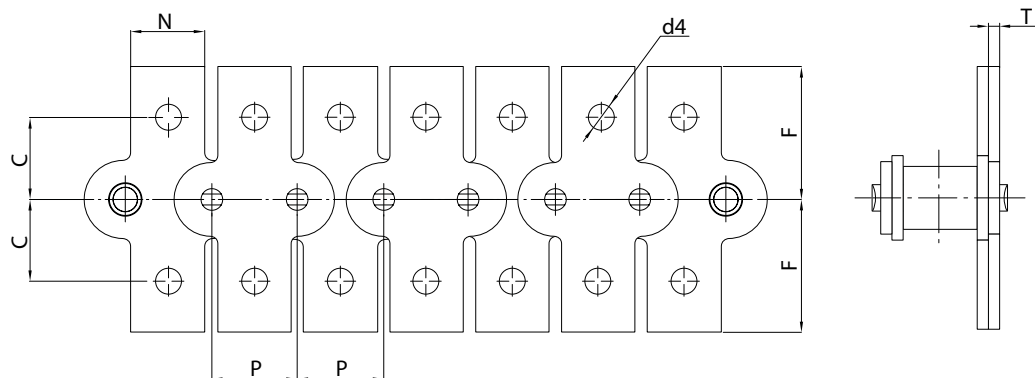

**SKK-1**

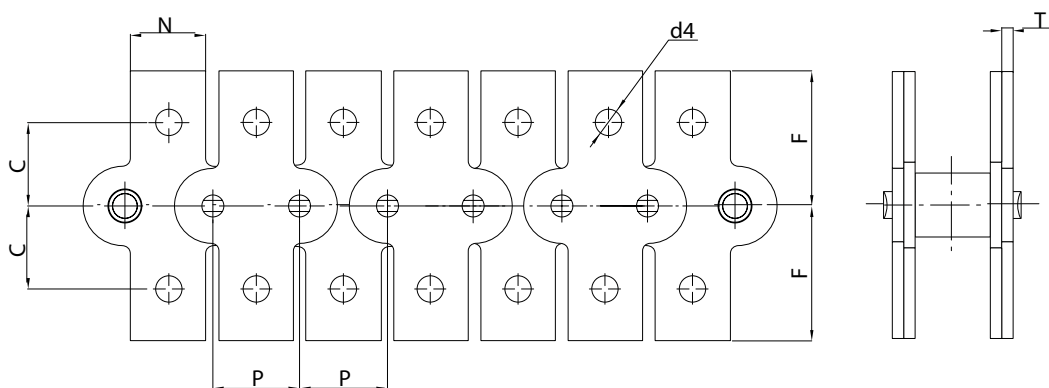

BS Chain No.	ANSI Chain No.	P mm	N mm	C mm	F mm	T mm	d4 mm
08A	40	12.700	9.5	12.70	9.05	1.50	3.4
10A	50	15.875	12.7	15.90	25.25	2.03	5.5
12A	60	19.050	15.9	18.30	29.33	2.42	5.5
16A	80	25.400	19.1	24.60	34.70	3.25	6.8
20A	100	31.750	25.4	31.80	43.30	4.00	9.2
24A	120	38.100	28.6	73.00	103.20	4.80	9.8
*06B	—	9.525	8.0	9.52	13.50	1.30	3.5
08B	—	12.700	9.5	13.35	18.90	1.60	4.3
10B	—	15.875	14.3	16.50	22.95	1.70	5.3
12B	—	19.050	16.0	21.45	28.60	1.85	6.4
16B	—	25.400	19.1	23.15	34.00	3.10	6.4
20B	—	31.750	35.0	30.50	45.70	3.50	9.0
24B	—	38.100	36.0	85.40	123.0	4.80	10.5

\*Straight plate chain.

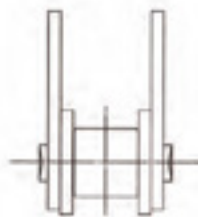
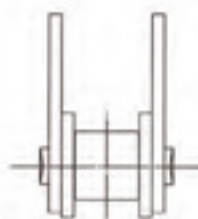
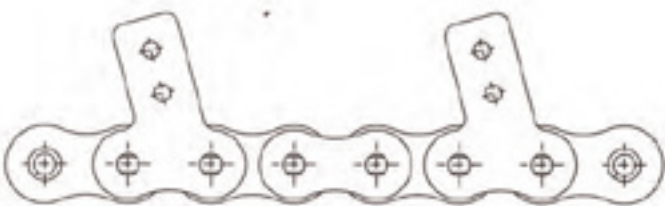
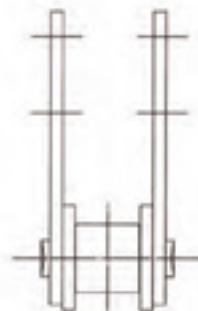
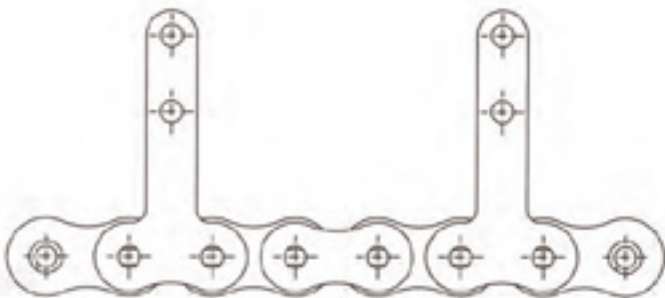
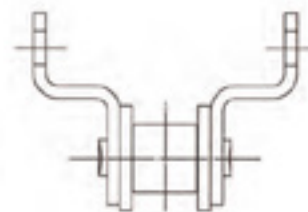
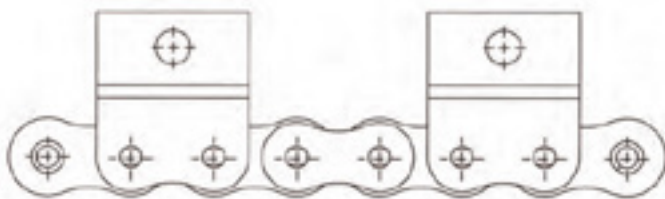
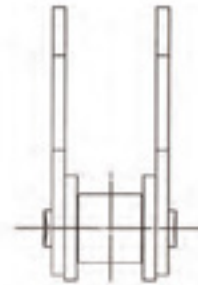
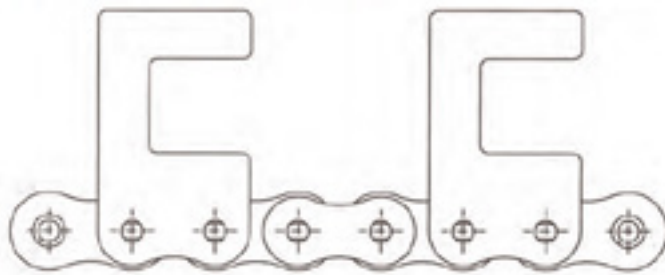

# Roller Chain with Extended Pins

D-1

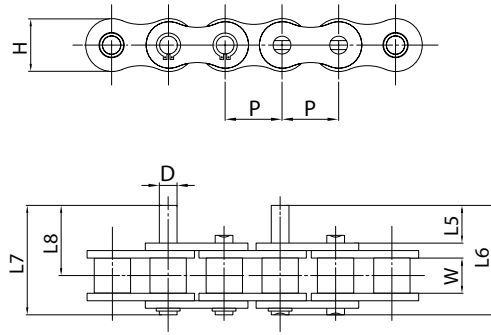

D-3

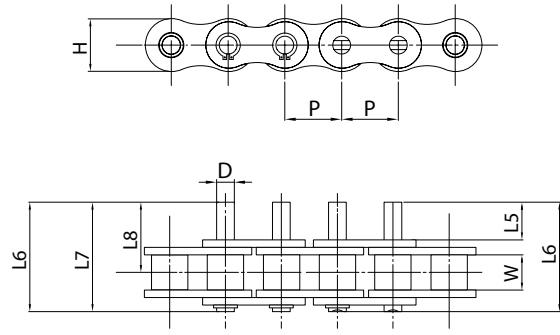

D-2

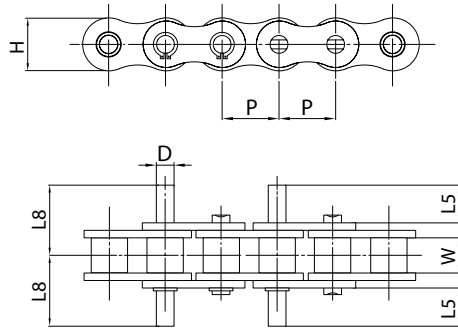

D-4

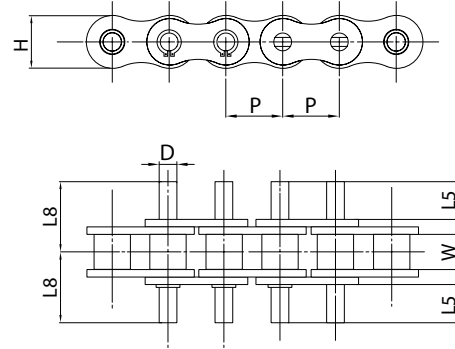

DIN/ISO Chain No.	ANSI Chain No.	P mm	W mm	D mm	L5 mm	L6 mm	L7 mm	L8 mm	H mm
06C	35	9.525	4.68	3.58	9.50	20.75	21.55	14.70	9.05
08A	40	12.70	7.85	3.98	9.50	25.65	26.75	16.80	12.07
10A	50	15.875	9.40	5.09	11.90	31.20	33.00	21.00	15.09
12A	60	19.05	12.57	5.96	14.30	38.60	40.60	25.85	18.08
16A	80	25.40	15.75	7.94	19.10	50.15	53.15	33.90	24.13
20A	100	31.75	18.90	9.54	23.80	60.30	64.60	41.75	30.18
24A	120	38.10	25.22	11.11	28.60	75.94	79.94	51.04	36.20
28A	140	44.45	25.22	12.71	33.30	84.60	89.20	57.50	42.24
32A	160	50.80	31.55	14.29	38.10	99.85	104.25	67.40	48.26
10B		15.875	9.65	5.08	11.90	29.70	31.20	20.30	14.73
12B		19.05	11.68	5.72	14.30	35.30	37.00	24.30	16.13
16B		25.40	17.02	8.28	19.10	53.20	54.50	35.30	21.08
20B		31.75	19.58	10.19	41.00	79.90	83.00	58.30	26.42
24B		38.10	25.40	14.63	50.70	101.40	105.80	74.70	33.40
28B		44.5	30.99	15.90	60.90	124.00	128.40	91.45	37.08
32B		50.8	30.99	17.80	64.80	126.80	131.80	92.30	42.29

## Extended Pin Additional Options

For customised chains and other enquirers, contact our team: [info@transdrive.com.au](mailto:info@transdrive.com.au)

**Oversize extended pins**

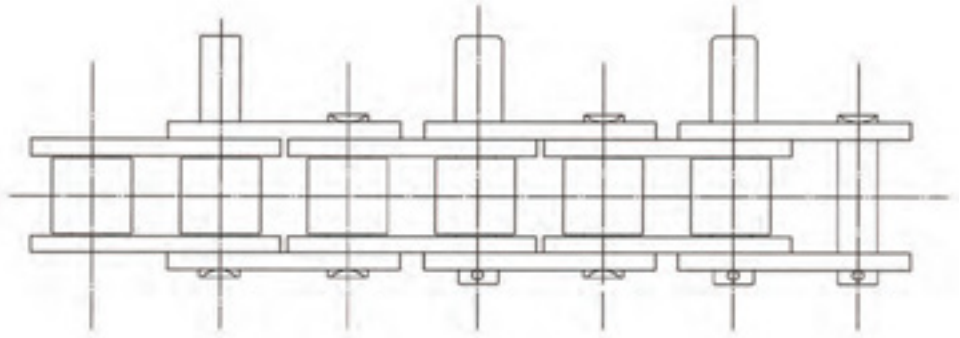

**Extended cottered pins**

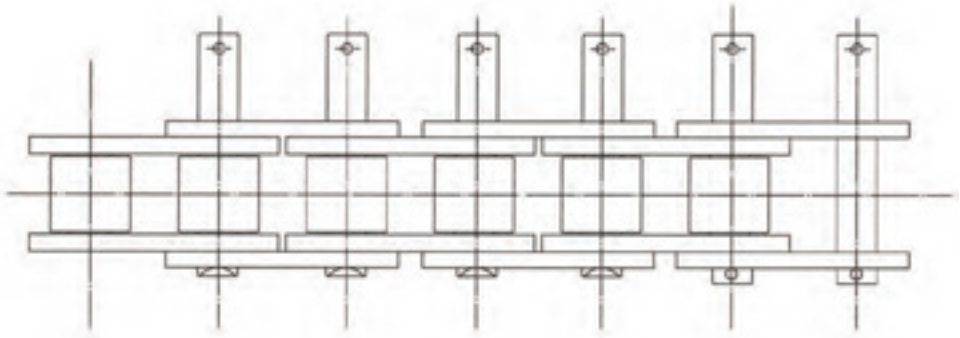

**Threaded pins**

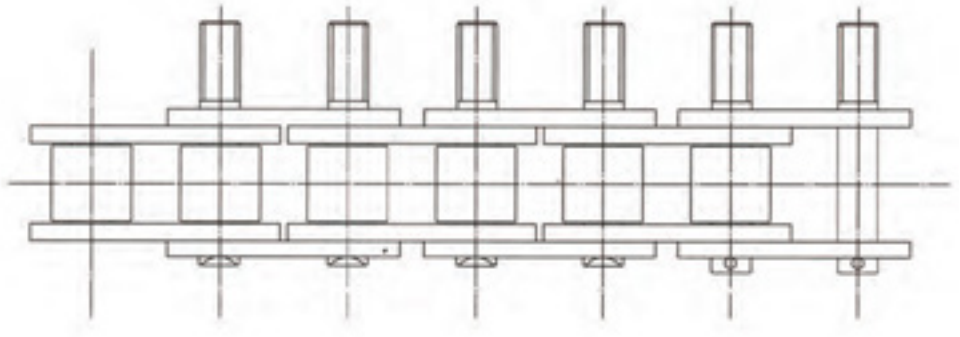

**Spiked pins**

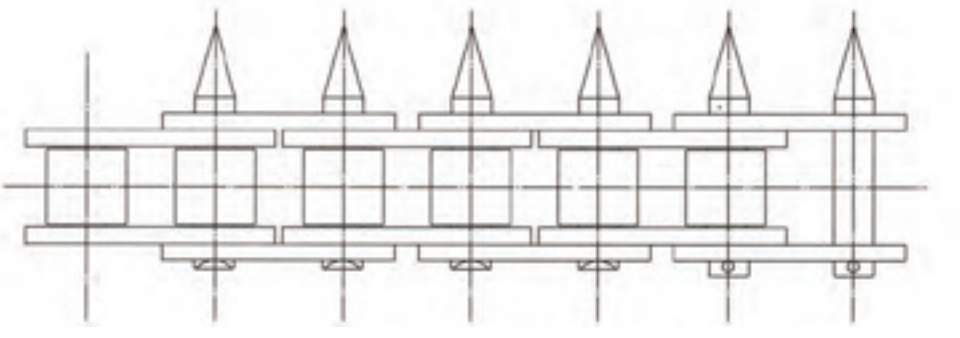

# Roller Chain with U-type Attached

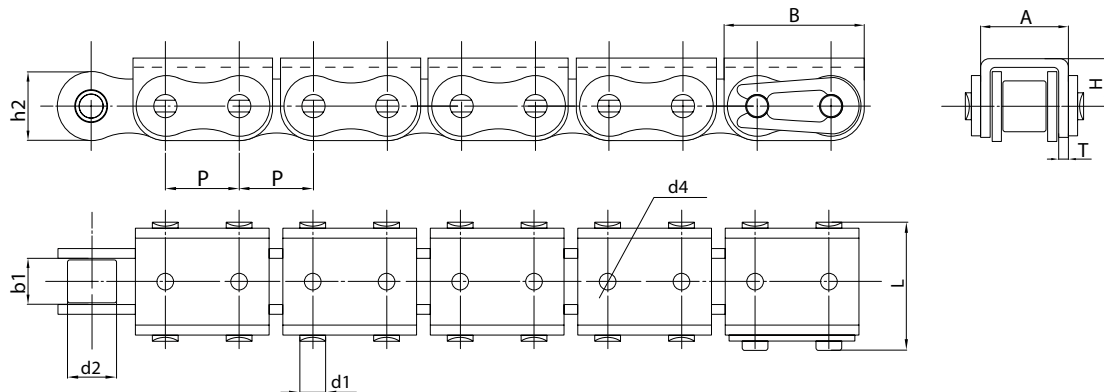

Chain No.	Pitch P mm	Roller Diameter d2 max mm	Width Between Inner Plates		Pin Diameter			Plate and attachment dimensions					Ultimate Tensile Strength kN mm	Weight Per Metre kg/m
			b1 min mm	b1 max mm	d1 max mm	L max mm	h2 max mm	A mm	B mm	H mm	d4 mm	T mm		
08B-U1	12.70	8.51	7.75	7.75	4.45	21.7	11.81	14.6	24.2	8.3	4	1.60	18.00	1.16
10B-U1	15.875	10.16	9.65	9.65	5.08	24.3	14.73	16.8	30.0	11.3	5	1.60	22.00	1.55
12B-U1	19.05	12.07	11.68	11.68	5.72	28.1	16.13	19.6	36.0	13.0	5	1.85	30.0	1.93
16B-U1	25.40	15.88	17.02	17.02	8.28	41.2	21.08	29.1	49.0	15.4	6	1.60	60.00	3.75
20B-U1	31.75	19.05	19.56	19.56	10.19	51.7	26.42	36.0	57.0	21.0	10	3.50	87.00	6.00
24B-U1	38.10	25.40	25.40	25.40	14.63	67.2	33.40	47.0	72.6	28.0	10	4.50	163.00	10.88

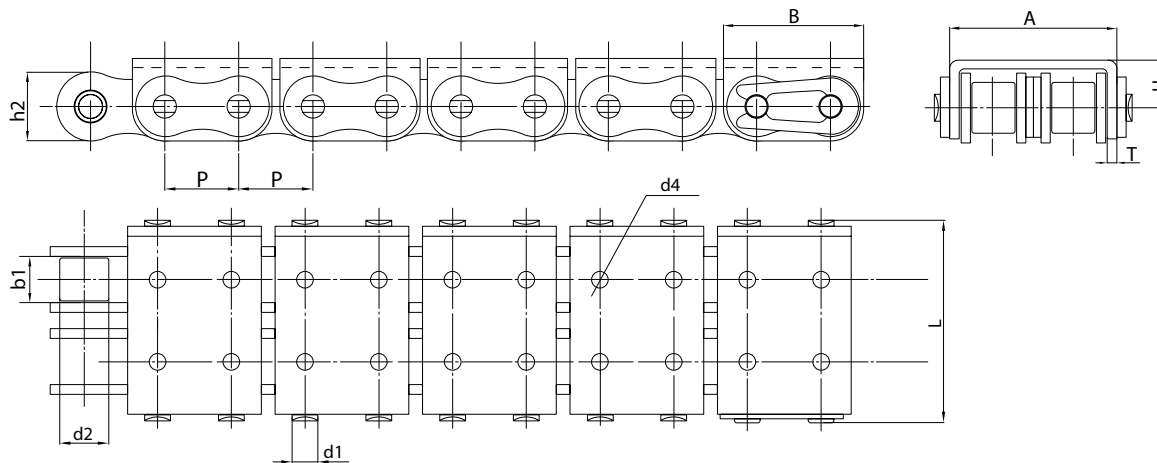

Chain No.	Pitch P mm	Roller Diameter d2 max mm	Width Between Inner Plates		Pin Diameter			Plate and attachment dimensions					Ultimate Tensile Strength kN mm	Weight Per Metre kg/m
			b1 min mm	b1 max mm	d1 max mm	L max mm	h2 max mm	A mm	B mm	H mm	d4 mm	T mm		
08B-U2	12.70	8.51	7.75	7.75	4.45	35.5	11.81	28.4	24.2	8.3	4	1.50	35.00	2.00
10B-U2	15.875	10.16	9.65	9.65	5.08	40.7	14.73	33.3	30.0	11.3	5	1.50	46.00	2.50
12B-U2	19.05	12.07	11.68	11.68	5.72	47.5	16.13	39.1	36.0	12.0	5	1.85	58.00	3.08
16B-U2	25.40	15.88	17.02	17.02	8.28	73.2	21.08	60.93	49.0	16.2	6	1.60	110.00	6.17



# Roller Chain with U-type Vulcanised Profiles

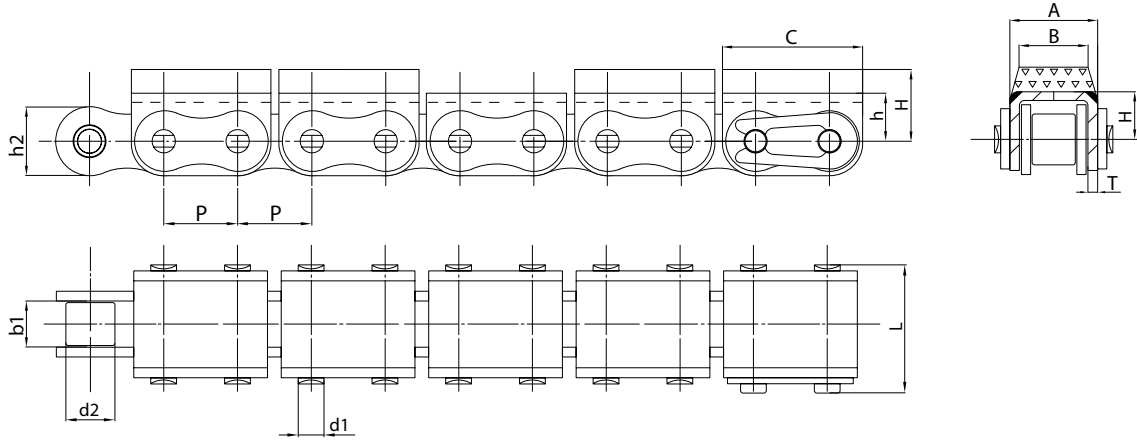

Chain No.	Pitch P mm	Roller Diameter d2 mm	Width Between Inner Plates b1 mm	Pin Diameter			Plate and attachment dimensions						Depth	Ultimate Tensile Strength kN	Weight Per Metre kg/m
				d1 mm	L mm	h2 mm	A mm	B mm	C mm	h mm	H mm	T mm			
08B-G1	12.70	8.51	7.75	4.45	21.7	114.6	11.6	24.2	8.3	12.3	1.60	18.00	18.60	1.20	
10B-G1	15.875	10.16	9.65	5.08	24.3	14.73	16.8	14.5	30.0	11.3	17.0	1.60	22.00	1.65	
12B-G1	19.05	12.07	11.68	5.72	28.1	16.13	19.6	16.6	36.0	13.0	21.0	1.85	30.0	2.03	
16B-G1	25.40	15.88	17.02	8.28	41.2	21.08	29.1	26.1	49.0	15.4	21.4	1.60	60.00	4.00	
20B-G1	31.75	19.05	19.56	10.19	51.7	26.42	36.0	30.0	57.0	21.0	27.0	3.50	87.00	6.23	
24B-G1	38.10	25.40	25.40	14.63	67.2	33.40	47.0	39.0	72.6	28.0	34.0	4.50	163.00	11.30	

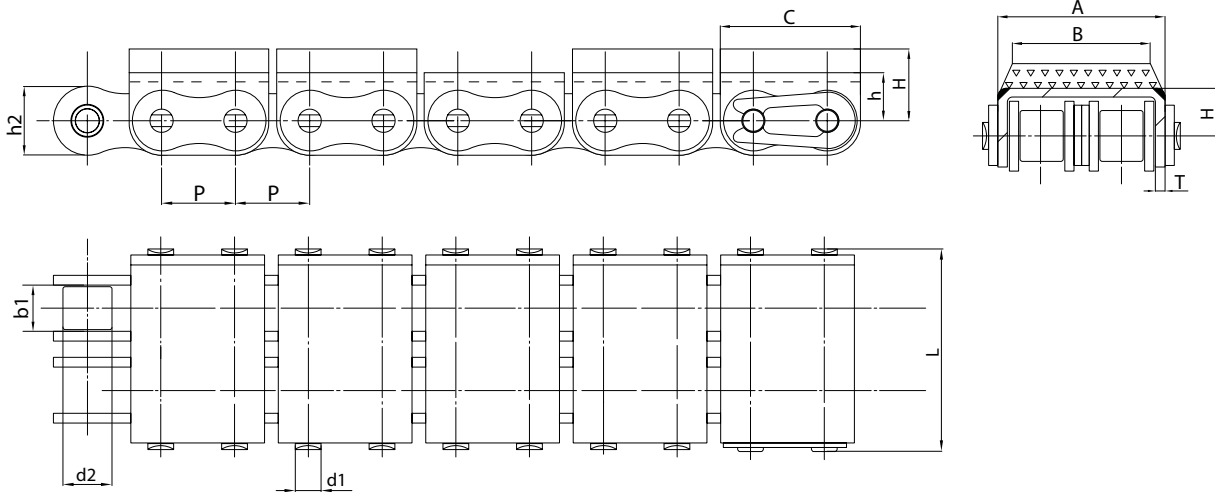

Chain No.	Pitch P mm	Roller Diameter d2 mm	Width Between Inner Plates b1 mm	Pin Diameter			Plate and attachment dimensions						Depth	Ultimate Tensile Strength kN	Weight Per Metre kg/m
				d1 mm	L mm	h2 mm	A mm	B mm	C mm	h mm	H mm	T mm			
08B-G2	12.70	8.51	7.75	4.45	35.5	11.81	28.4	23.4	24.2	8.3	12.3	1.50	35.00	2.10	
10B-G2	15.875	10.16	9.65	5.08	40.7	14.73	33.3	28.3	30.0	11.3	17.0	1.50	46.00	2.60	
12B-G2	19.05	12.07	11.68	5.72	47.5	16.13	39.1	34.1	36.0	13.0	16.0	1.85	58.00	3.25	

# Double Pitch Attachments

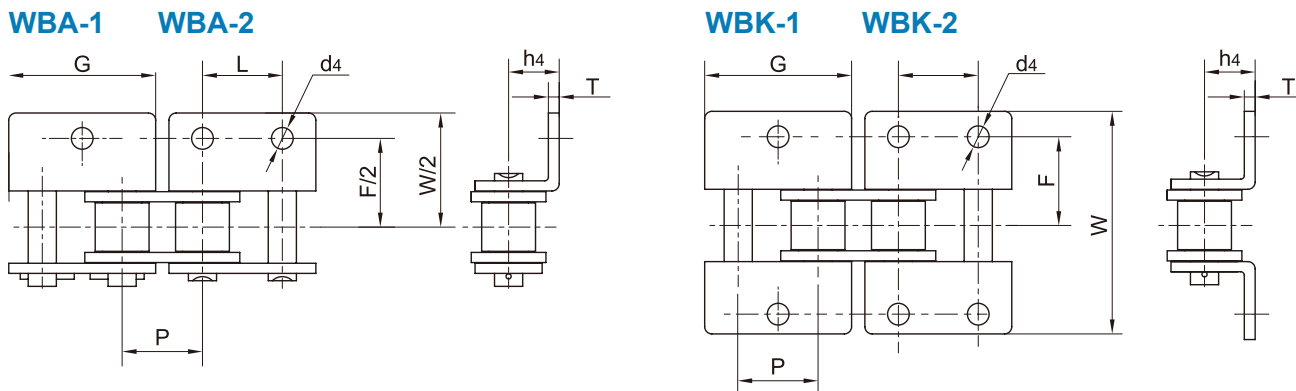

ANSI Chain No.	P mm	G mm	L mm	F mm	W mm	T mm	h4 mm	d4 mm
35	9.525	16.82	9.525	19.00	26.2	1.30	6.35	2.8
40	12.700	23.00	12.700	25.40	35.6	1.50	7.90	3.4
50	15.875	28.80	15.875	31.75	46.8	2.03	10.30	5.5
60	19.050	34.65	19.050	38.10	56.4	2.42	11.90	5.5
80	25.400	45.90	25.400	50.80	73.2	3.25	15.90	6.8
100	31.750	57.65	31.750	63.50	89.8	4.00	19.80	9.2
120	38.100	69.30	38.100	76.20	108.8	4.80	23.00	9.8
140	44.450	80.45	44.450	88.90	123.0	5.60	28.60	11.4
160	50.800	92.00	50.800	101.60	142.8	6.40	31.75	13.1
200	63.500	115.5	63.500	127.00	179.00	8.00	42.88	16.3

BS Chain No.	P mm	G mm	L mm	F mm	W mm	T mm	h4 mm	d4 mm
08B	12.700	24.00	12.700	25.40	36.4	1.60	8.90	4.3
10B	15.875	29.58	15.875	31.80	44.6	1.70	10.31	5.3
12B	19.050	34.05	19.050	38.10	52.4	1.85	13.46	6.4
16B	25.400	46.40	25.400	50.80	72.6	3.10	15.88	6.4
20B	31.750	58.10	31.750	63.00	100.5	3.50	19.80	9.0
24B	38.100	71.30	38.100	76.20	108.4	4.8	26.67	10.5
28B	44.450	81.1	44.450	88.90	123.0	6.0	28.58	13.1
32B	50.800	92.8	50.800	101.60	142.8	6.0	31.75	13.1

# Double Pitch Attachments

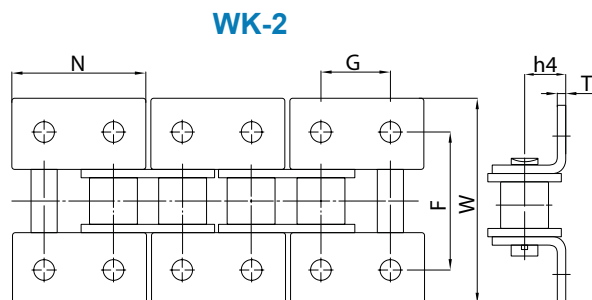
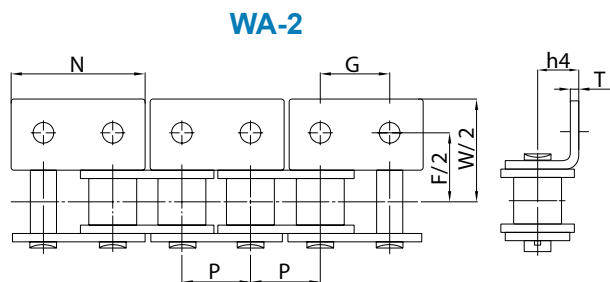
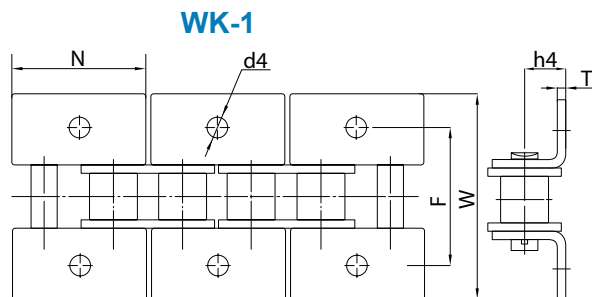
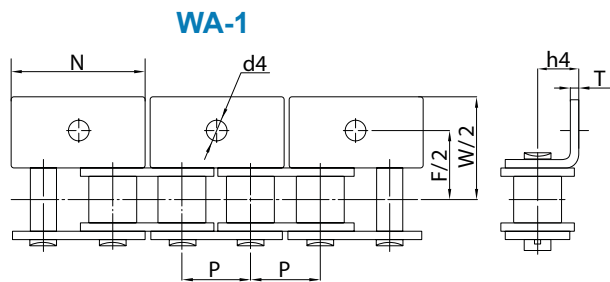

BS Chain No.	ANSI Chain No.	p mm	N mm	G mm	F mm	W mm	T mm	h4 mm	d4 mm
04C	25	6.350	11.41	6.350	13.80	23.20	0.80	4.30	3.4
06C	35	9.525	17.32	9.525	19.00	28.60	1.30	6.35	2.8
08A	40	12.700	23.00	12.700	25.40	35.60	1.50	7.90	3.4
085	41	12.700	21.20	12.700	24.00	35.00	1.30	7.20	3.6
10A	50	15.875	28.80	15.875	31.75	46.80	2.03	10.30	5.5
12A	60	19.050	34.65	19.050	38.10	56.40	2.42	11.90	5.5
16A	80	25.400	45.90	25.400	50.80	73.20	3.25	15.90	6.8
20A	100	31.750	57.65	31.750	63.50	89.80	4.00	19.80	9.2
24A	120	38.100	69.30	38.100	76.20	108.80	4.80	23.00	9.8
28A	140	44.450	80.45	44.450	88.90	123.00	5.60	28.60	11.4
32A	160	50.800	92.00	50.800	101.60	142.80	6.40	31.75	13.1
40A	200	63.500	115.50	63.500	127.00	179.00	8.00	42.88	16.3
*06B	—	9.525	17.72	9.525	19.04	27.00	1.30	6.50	3.5
08B	—	12.700	23.30	12.700	25.40	36.40	1.60	8.90	4.3
10B	—	15.875	29.58	15.875	31.80	44.60	1.70	10.31	5.3
12B	—	19.050	34.05	19.050	38.10	52.40	1.85	13.46	6.4
16B	—	25.400	46.40	25.400	50.80	72.60	3.10	15.88	6.4
20B	—	31.750	58.10	31.750	63.00	100.50	3.50	19.80	9.0
24B	—	38.100	71.30	38.100	76.20	108.40	4.80	26.67	10.5
28B	—	44.450	81.10	44.450	88.90	123.00	6.00	28.58	13.10
32B	—	50.800	92.80	50.800	101.60	142.80	6.00	31.75	13.10

\*Straight plate chain.

# Double Pitch Attachments

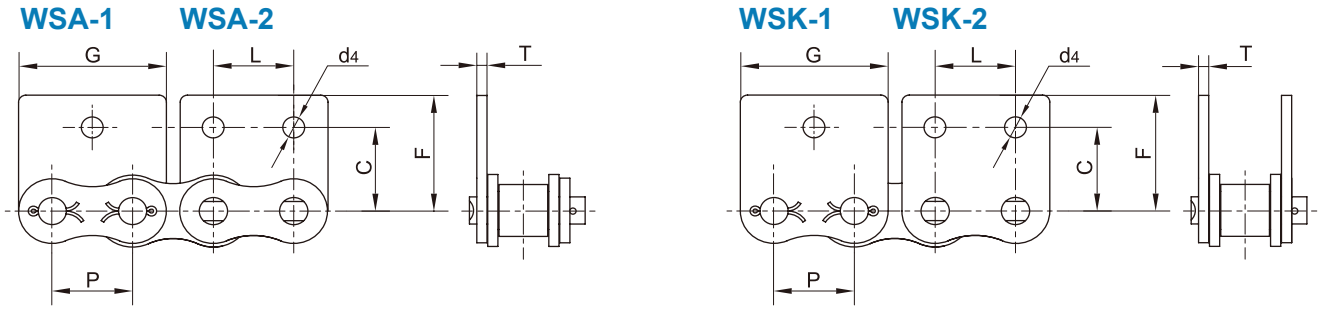

ANSI Chain No.	P mm	G mm	L mm	C mm	F mm	T mm	d4 mm
35	9.525	16.82	9.525	19.00	26.2	1.30	2.8
40	12.700	23.00	12.700	25.40	35.6	1.50	3.4
50	15.875	28.80	15.875	31.75	46.8	2.03	5.5
60	19.050	34.65	19.050	38.10	56.4	2.42	5.5
80	25.400	45.90	25.400	50.80	73.2	3.25	6.8
100	31.750	57.65	31.750	63.50	89.8	4.00	9.2
120	38.100	69.30	38.100	76.20	108.8	4.80	9.8
140	44.450	80.45	44.450	88.90	123.0	5.60	11.4
160	50.800	92.00	50.800	101.60	142.8	6.40	13.1
200	63.500	115.5	63.500	127.00	179.00	8.00	16.3

BS Chain No.	P mm	G mm	L mm	C mm	F mm	T mm	d4 mm
08B	12.700	24.00	12.700	25.40	36.4	1.60	4.3
10B	15.875	29.58	15.875	31.80	44.6	1.70	5.3
12B	19.050	34.05	19.050	38.10	52.4	1.85	6.4
16B	25.400	46.40	25.400	50.80	72.6	3.10	6.4

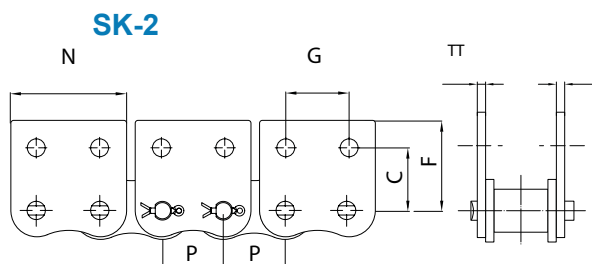
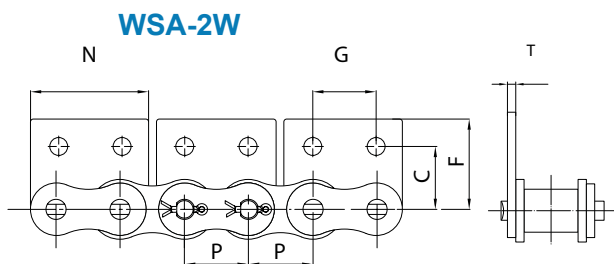
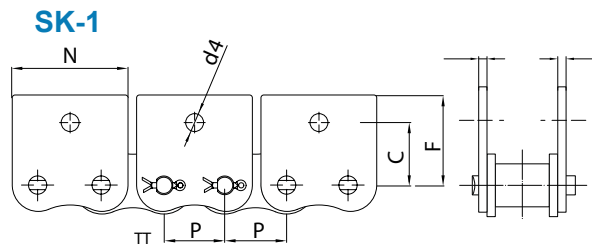
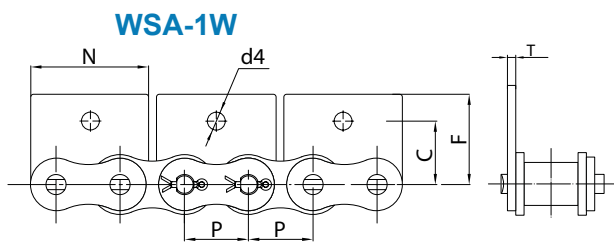

BS Chain No.	ANSI Chain No.	p mm	N mm	G mm	C mm	F mm	T mm	d4 mm
04C	25	6.350	11.41	6.350	7.95	11.70	0.80	3.4
06C	35	9.525	17.32	9.525	9.50	14.55	1.30	2.8
08A	40	12.700	23.00	12.700	12.70	17.40	1.50	3.4
085	41	12.700	21.20	12.700	11.85	16.55	1.30	3.6
10A	50	15.875	28.80	15.875	15.90	23.05	2.03	5.5
12A	60	19.050	34.65	19.050	18.30	26.86	2.42	5.5
16A	80	25.400	45.90	25.400	24.60	35.45	3.25	6.8
20A	100	31.750	57.65	31.750	31.80	44.00	4.00	9.2
24A	120	38.100	69.30	38.100	36.50	51.60	4.80	9.8
28A	140	44.450	80.45	44.450	44.50	62.00	5.60	11.4
32A	160	50.800	92.00	50.800	50.80	69.85	6.40	13.1
40A	200	63.500	115.5	63.500	63.5b	88.90	8.00	16.3
*06B	—	9.525	17.72	9.525	9.50	13.50	1.30	3.5
08B	—	12.700	23.30	12.700	13.35	18.90	1.60	4.3
10B	—	15.875	29.58	15.875	16.50	22.95	1.70	5.3
12B	—	19.050	34.05	19.050	21.45	28.60	1.85	6.4
16B	—	25.400	46.40	25.400	23.15	34.00	3.10	6.4
20B	—	31.750	58.10	31.750	30.50	45.70	3.50	9.0
24B	—	38.100	71.30	38.100	42.70	61.50	4.80	10.5

\*Straight plate chain.

# Double Pitch Attachments

## Double Pitch Oversize Roller Chain with G-type Attachments

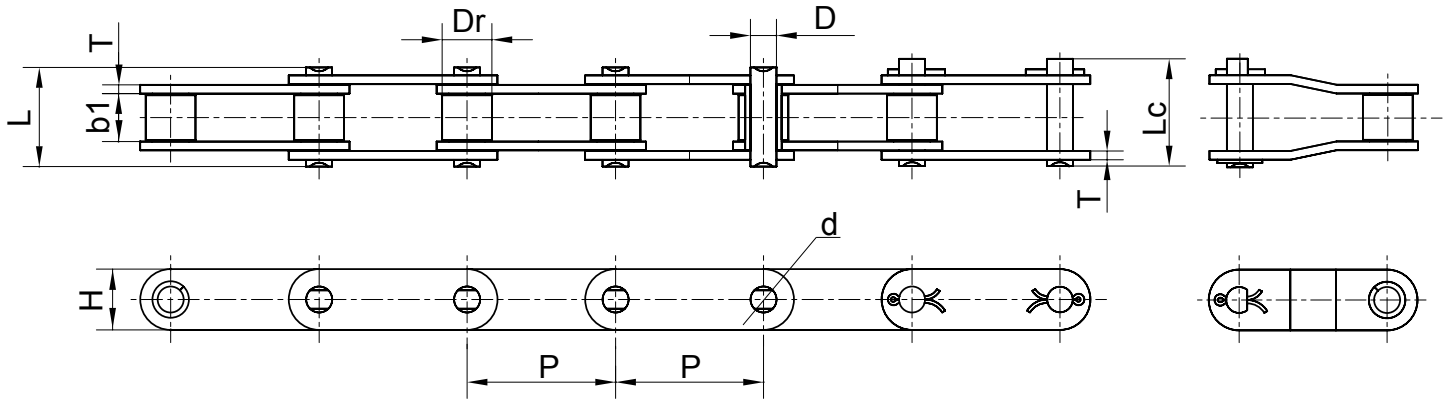

ISO Chain No.	ANSI Chain No.	Pitch P mm	Roller Diameter Dr max mm	Width Between Inner Plates W min mm	Pin Diameter D max mm	Centre Hole Diameter d max mm	Pin Length		Plate Depth H max mm	Plate Thickness T max mm	Tensile Strength		Weight Per Metre kg/m
							L max mm	Lc max mm			Ultimate min kN	Average kN	
C208AL	C2042	25.40	15.88	7.85	3.98	4.10	17.80	19.80	12.07	1.50	13.80	17.80	0.86
C210AL	C2052	31.75	19.05	9.40	5.09	5.20	21.80	23.80	15.09	2.03	21.80	29.20	1.29
C212AL	C2062	38.10	22.23	12.57	5.96	6.10	26.90	29.40	18.08	2.42	31.10	41.60	1.65
C216AL	C2082	50.80	28.58	15.75	7.94	8.10	33.50	36.50	24.13	3.25	55.60	72.00	3.15
C220AL	C2102	63.50	39.67	18.90	9.54	9.70	41.10	44.60	30.18	4.00	86.70	110.20	4.88
C224AL	C2122	76.20	44.45	25.22	11.11	11.30	50.80	54.80	36.20	4.80	124.60	157.20	7.69
C232AL	C2162	101.6	57.15	31.55	14.29	14.50	65.50	70.50	48.26	6.40	222.40	275.00	12.00
C208AHL	C2042H	25.40	15.88	7.85	3.98	4.10	20.10	22.10	12.07	2.03	13.80	17.80	1.08
C210AHL	C2052H	31.75	19.05	9.40	5.09	5.20	23.80	25.80	15.09	2.42	21.80	29.20	1.63
C212AHL	C2062H	38.10	22.23	12.57	5.96	6.10	30.40	32.90	18.08	3.25	31.10	41.60	2.10
C216AHL	C2082H	50.80	28.58	15.75	7.94	8.10	36.70	39.70	24.13	4.00	55.60	72.00	3.62
C220AHL	C2102H	63.50	39.67	18.90	9.54	9.70	44.50	48.00	30.18	4.80	86.70	110.20	5.40
C224AHL	C2122H	76.20	44.45	25.22	11.11	11.30	54.20	58.20	36.20	5.60	124.60	157.20	8.30
C232AHL	C2162H	101.60	57.15	31.55	14.29	14.50	68.70	73.70	48.26	7.15	222.40	275.00	12.90

# Double Pitch Attachments

## Double Pitch Small Roller Chain with G-type Attachments

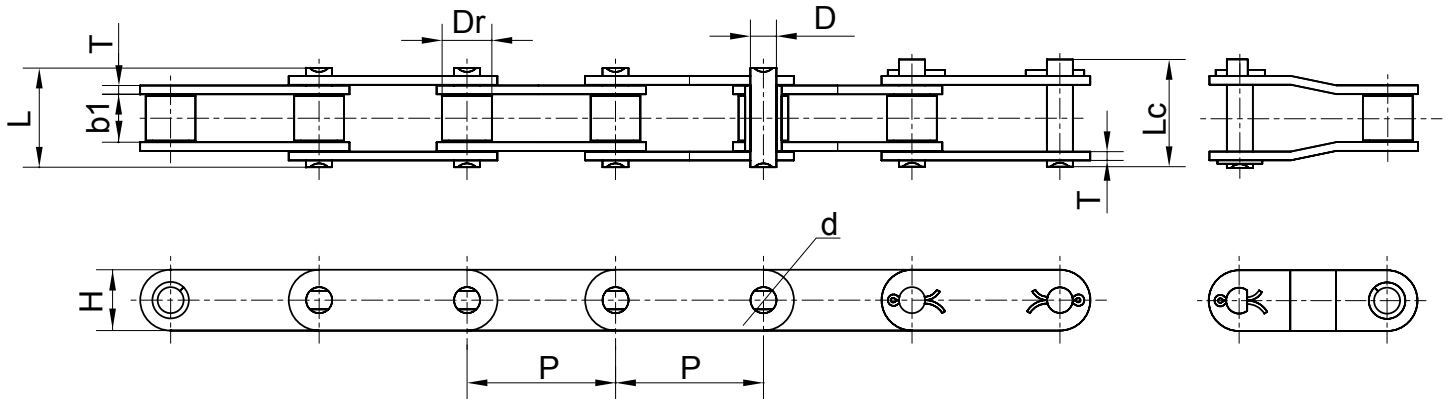

ISO Chain No.	ANSI Chain No.	Pitch P mm	Roller Diameter Dr max mm	Width Between Inner Plates W min mm	Pin Diameter D max mm	Centre Hole Diameter d max mm	Pin Length		Plate Depth H max mm	Plate Thickness T1 max mm	Tensile Strength		Weight Per Metre kg/m
							L max mm	Lc max mm			Ultimate min kN	Average kN	
C208A	C2040	25.40	7.92	7.85	3.98	4.10	17.80	19.80	12.07	1.50	13.80	17.80	0.56
C210A	C2050	31.75	10.16	9.40	5.09	5.20	21.80	23.80	15.09	2.03	21.80	29.20	0.80
C212A	C2060	38.10	11.91	12.57	5.96	6.10	26.90	29.40	18.08	2.42	31.10	41.60	1.15
C216A	C2080	50.80	15.88	15.75	7.94	8.10	33.50	36.50	24.13	3.25	55.60	72.00	2.10
C220A	C2100	63.50	19.05	18.90	9.54	9.70	41.10	44.60	30.18	4.00	86.70	110.20	3.08
C224A	C2120	76.20	22.23	25.22	11.11	11.30	50.80	54.80	36.20	4.80	124.60	157.20	4.68
C232A	C2160	101.6	28.58	7.75	14.29	14.50	65.50	70.50	48.26	6.40	222.40	275.00	8.25
C208AH	C2040H	25.40	7.92	9.65	3.98	4.10	20.10	22.10	12.07	2.03	13.80	17.80	0.68
C210AH	C2050H	31.75	10.16	11.68	5.09	5.20	23.80	25.80	15.09	2.42	21.80	29.20	0.96
C212AH	C2060H	38.10	11.91	17.02	5.96	6.10	30.40	32.90	18.08	3.25	31.10	41.60	1.46
C216AH	C2080H	50.80	15.88	19.56	7.94	8.10	36.70	39.70	24.13	4.00	55.60	72.00	2.58
C220AH	C2100H	63.50	19.05	25.40	9.54	9.70	44.50	48.00	30.18	4.80	86.70	110.20	3.59
C224AH	C2120H	76.20	23.23	30.99	11.11	11.30	54.20	58.20	36.20	5.60	124.60	157.20	5.29
C232AH	C2160H	101.60	28.58	30.99	14.29	14.50	68.70	73.70	48.26	7.15	222.40	275.00	9.10

### BA-1

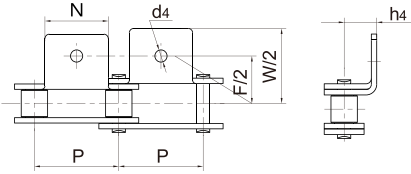

### A-1

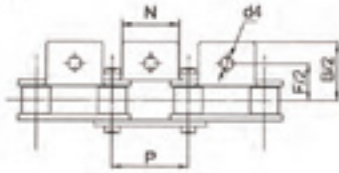

### K-1

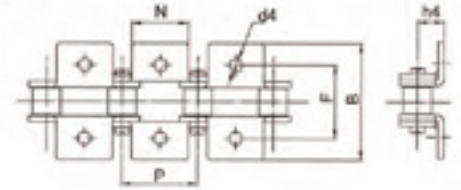

### BA-2

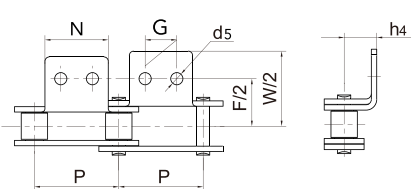

### A-2

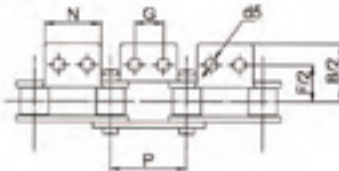

### K-2

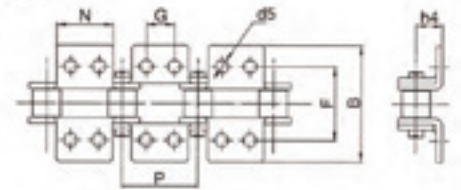

### BK-1

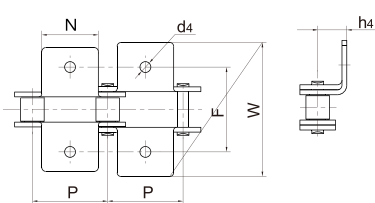

### AA-1

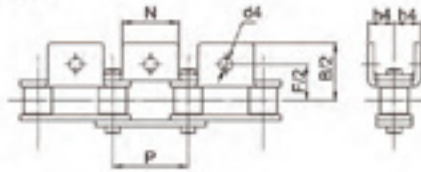

### KK-1

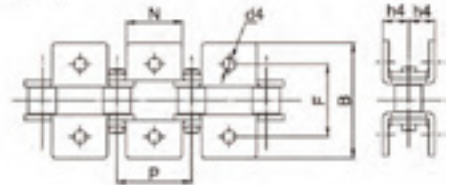

### BK-2

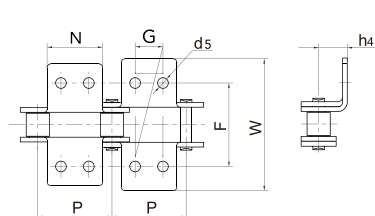

### AA-2

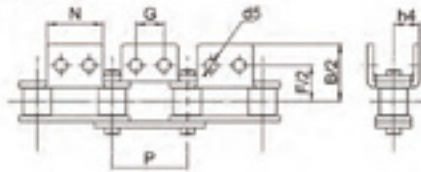

### KK-2

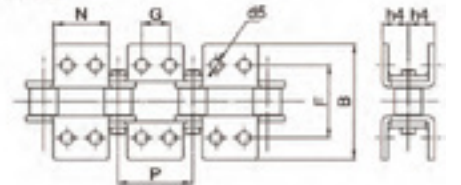

ANSI Chain No.				p mm	N mm	G mm	F mm	B mm	h4 mm	d5 mm
C2040	C2040H	C2042	C2042H	25.40	19.10	9.50	25.40	38.60	9.10	3.60
C2050	C2050H	C2052	C2052H	31.75	23.80	11.90	31.80	48.40	11.10	5.20
C2060	C2060H	C2062	C2062H	38.10	28.60	14.30	42.90	63.00	14.70	5.20
C2080	C2080H	C2082	C2082H	50.80	38.10	19.10	55.60	71.40	19.10	6.80
C2100	C2100H	C2102	C2102H	63.50	47.60	23.80	66.70	99.80	23.40	8.70
C2120	C2120H	C2122	C2122H	76.20	57.20	28.60	79.40	121.40	27.80	14.00
C2160	C2160H	C2162	C2162H	101.60	76.20	38.10	104.80	155.60	36.50	18.00



**SA-1**

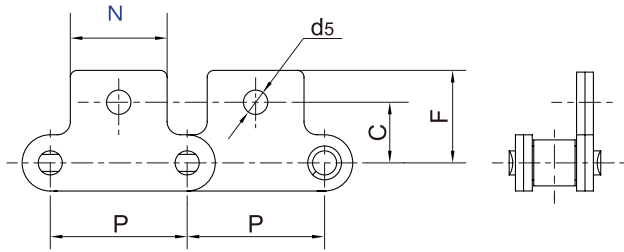

**SK-1**

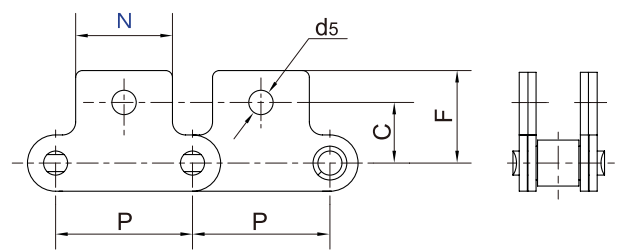

**SA-2**

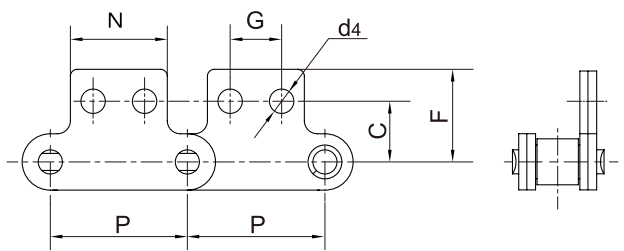

**SK-2**

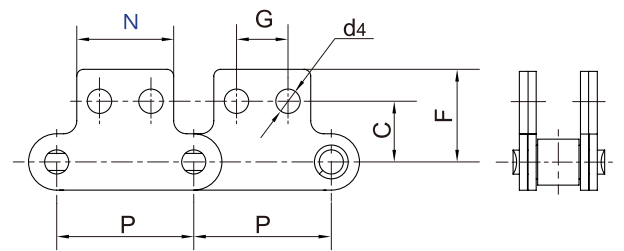

ANSI Chain No.				P mm	N mm	G mm	M1 mm	M2 mm	K mm	d4 mm	d5 mm
C2040	C2040H	C2042	C2042H	25.40	19.10	9.50	11.10	13.60	19.80	5.20	3.60
C2050	C2050H	C2052	C2052H	31.75	23.80	11.90	14.30	15.90	24.60	6.80	5.20
C2060	C2060H	C2062	C2062H	38.10	28.60	14.30	17.50	19.10	30.60	8.70	5.20
C2080	C2080H	C2082	C2082H	50.80	38.10	19.10	22.20	25.40	40.50	10.30	6.80
C2100	C2100H	C2102	C2102H	63.50	47.60	23.80	28.60	31.80	50.40	14.30	8.70
C2120	C2120H	C2122	C2122H	76.20	57.20	28.60	33.30	37.30	59.90	16.00	14.00
C2160	C2160H	C2162	C2162H	101.60	76.20	38.10	44.50	50.80	78.60	22.00	18.00

### SAA-1

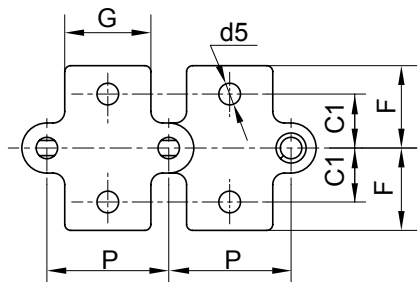

### SAA-2

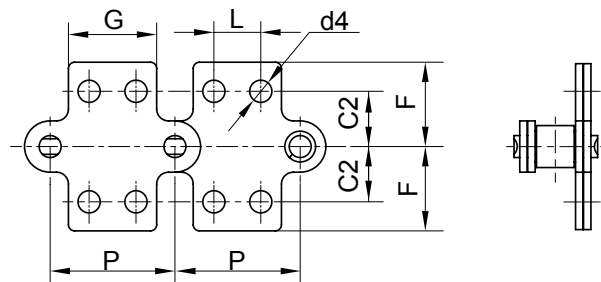

### SKK-1

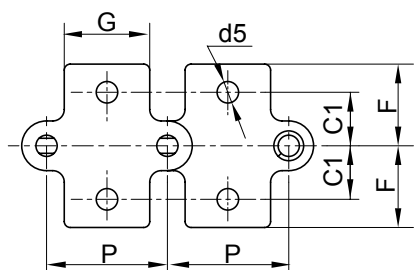

### SKK-2

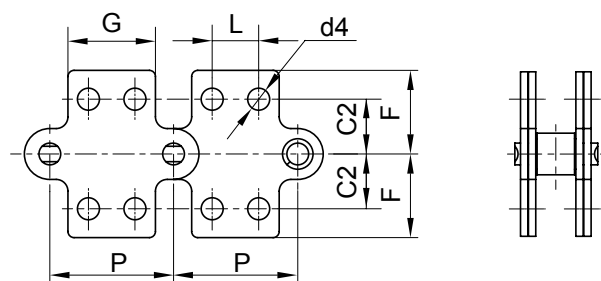

Chain No.		P mm	G mm	L mm	C1 mm	C2 mm	F mm	d4 mm	d5 mm
C208A C208AL	C2040 C2042	25.40	19.10	9.50	11.10	13.50	20.50	3.40	5.50
C208B B208BL	—	25.40	23.20	12.70	11.10	13.50	20.50	4.50	5.50
C210A C210AL	C2050 C2052	31.75	23.80	11.90	14.30	15.90	25.00	5.50	6.60
C212A C212AL	C2060 C2062	38.10	28.60	14.30	17.50	19.10	32.90	5.50	9.20
C212AH C212AHL	C2060H C2062H	38.10	28.60	14.30	17.50	19.10	32.90	5.50	9.20
C216A C216AL	C2080 C2082	50.80	38.10	19.10	22.20	25.40	43.50	6.60	11.00
C216AH A216AHL	C2080H A2082H	50.80	38.10	19.10	22.20	25.40	43.50	6.60	11.00

# Double Pitch Attachments

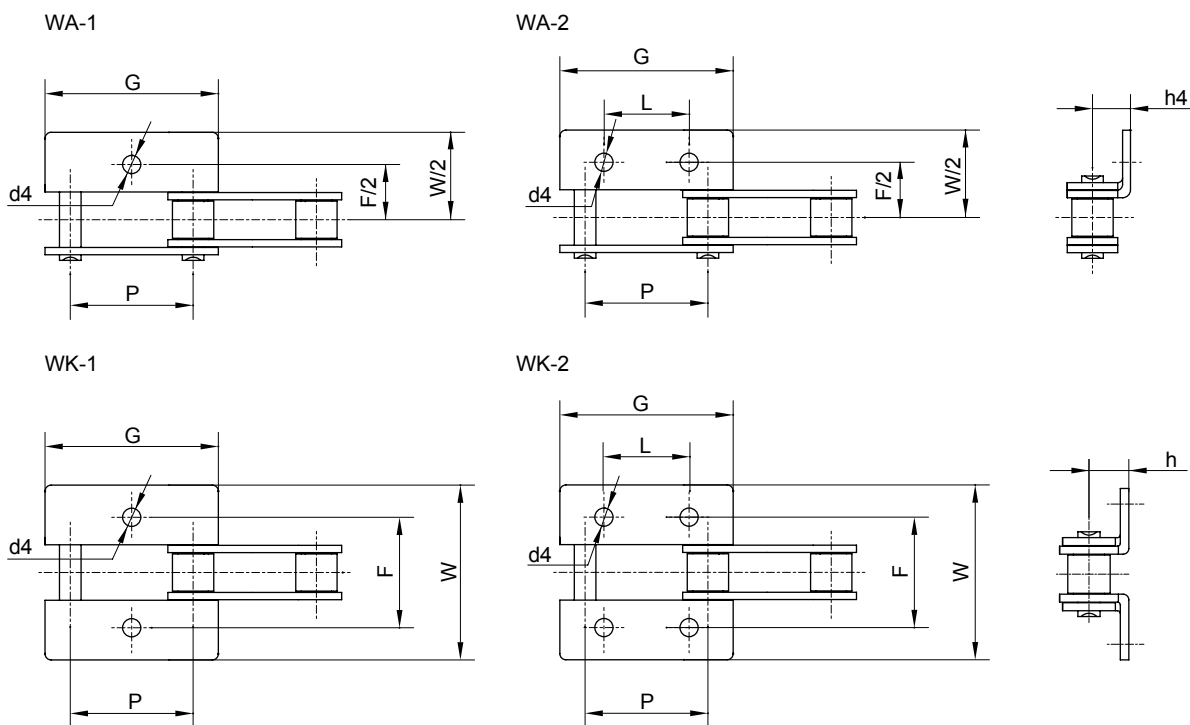

Chain No.	P mm	G mm	L mm	F mm	W mm	h4 mm	d4 mm
C2040K1F2	25.40	37.00	—	62.00	110.00	9.10	7.00
C2042HF1	25.40	37.40	—	42.50	65.50	6.00	7.00
C2052WA1F2	31.75	46.80	—	76.20	95.20	7.50	7.10
C2062WA2F1	38.10	56.10	38.10	42.90	67.80	14.70	6.50
C2062WK2F2	38.10	56.10	38.10	43.00	68.00	14.70	7.80
C2062HWA1F4	38.10	55.60	—	76.20	95.30	8.70	7.10
C2062HWA2	38.10	56.10	14.30	42.90	67.80	14.70	5.50
C2062HWA2F4	38.10	55.60	38.10	76.20	95.30	8.70	7.10
C216ALF5	50.80	74.80	44.30	62.20	88.00	19.10	7.00
C2082F12	50.80	74.80	50.80	55.60	88.00	19.10	8.40
C2082F24	50.80	74.80	56.80	55.60	87.80	19.10	6.80
C2082HF1A2	50.80	74.80	30.00	60.00	84.00	18.00	8.50
C2080HWK2	50.80	74.80	50.80	55.60	87.80	19.10	6.80
C208BK2F	25.40	37.20	12.70	28.00	42.00	8.50	5.50
212BWK2F1	38.10	54.10	19.00	35.20	54.80	12.20	6.40
212BWK2F2	38.10	54.10	19.00	35.00	54.80	12.70	7.00
216BWA2F1	50.80	71.80	25.40	58.00	80.00	17.00	8.40

# Double Pitch with Extended Pins

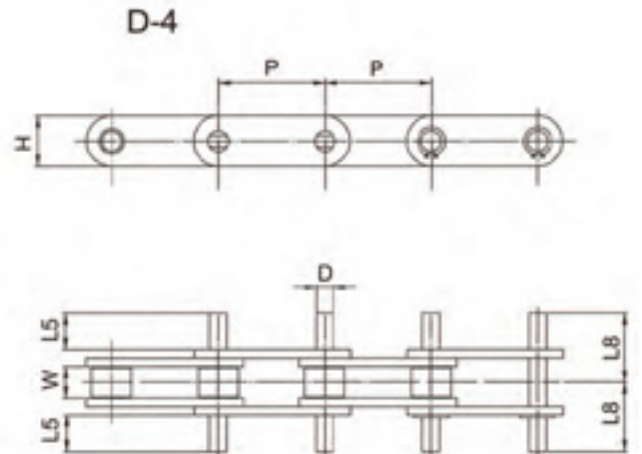
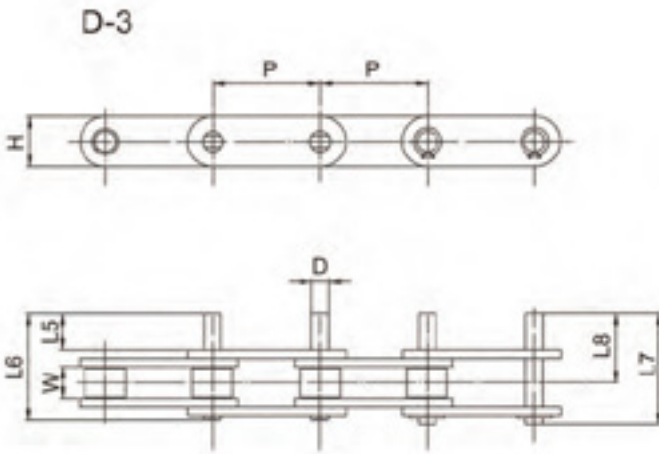
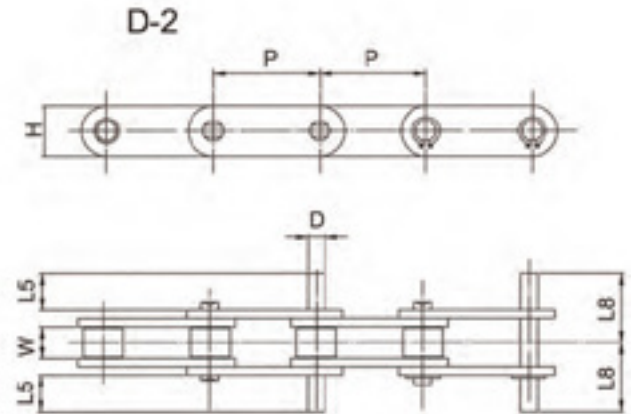
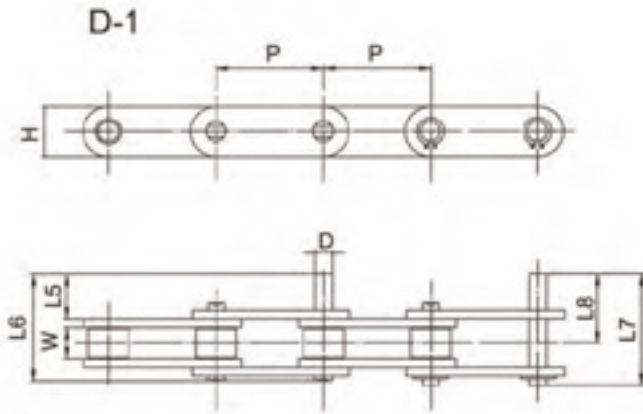

ANSI Chain No.		P mm	W mm	D mm	L5 mm	L6 mm	L7 mm	L8 mm	H mm
Small Roller	Large Roller								
C2040	C2042	25.40	7.85	3.98	9.50	25.65	26.75	16.80	12.07
C2050	C2052	31.75	9.40	5.09	11.90	31.20	33.00	21.00	15.09
C2060	C2062	38.10	12.57	5.96	14.30	38.60	40.60	25.85	18.08
C2080	C2082	50.80	15.75	7.94	19.10	50.15	53.15	33.90	24.13
C2100	C2102	63.50	18.90	9.54	23.80	60.30	64.60	41.75	30.18
C2120	C2122	76.20	25.22	11.11	28.60	75.94	79.94	51.64	36.20
C2140	C2142	88.90	25.22	12.71	33.30	84.60	89.20	57.50	42.24
C2160	C2162	101.60	31.55	14.29	38.10	99.85	104.25	67.40	48.26

# Double Pitch with Extended Pins

**D-1**

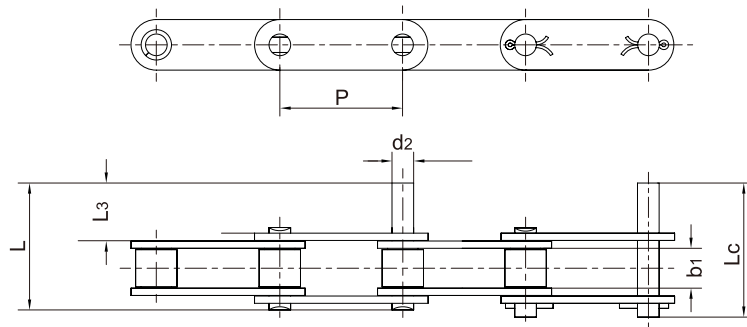

**D-3**

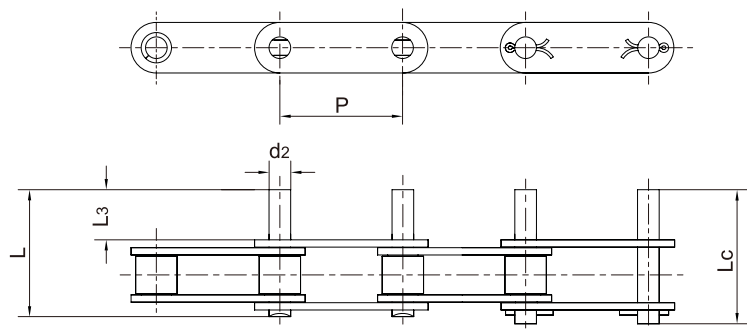

Chain No.		P mm	b1 mm	d2 mm	L3 mm	L mm	Lc mm
Small Roller	Large Roller						
C2040	C2042	25.40	7.85	3.96	9.5	25.1	26.2
C2050	C2052	31.75	9.40	5.08	11.9	31.3	33.1
C2060	C2062	38.10	12.57	5.94	14.3	38.6	40.6
C2060H	C2062H	38.10	12.57	5.94	14.3	42.0	43.8
C2080	C2082	50.80	15.75	7.92	19.1	50.3	53.3
C2080H	C2082H	50.80	15.75	7.92	19.1	53.5	55.0
C2100	C2102	63.50	18.90	9.53	23.8	61.8	66.1
C2100H	C2102H	63.50	18.90	9.53	23.8	65.0	68.3
C2120H	C2122H	76.20	25.22	11.10	28.6	79.6	83.6
C2160H	C2162H	101.60	31.55	14.27	38.1	103.0	107.8

# Double Pitch Chain Special Attachments Examples

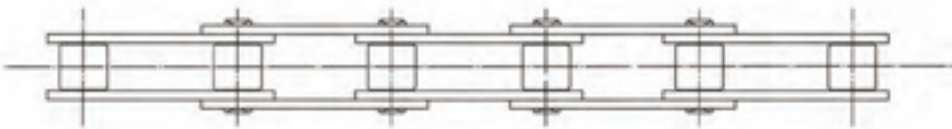
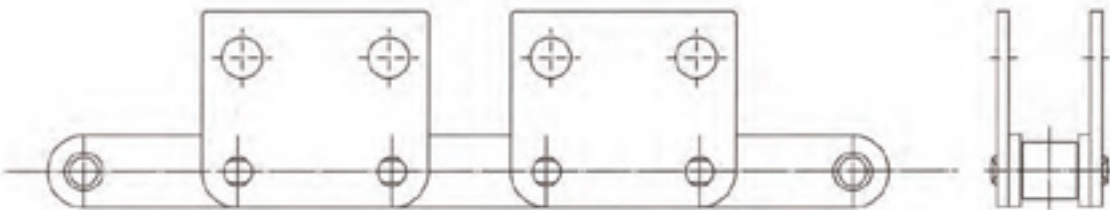
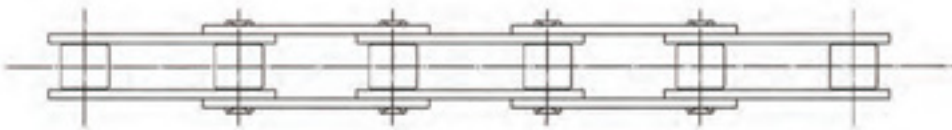
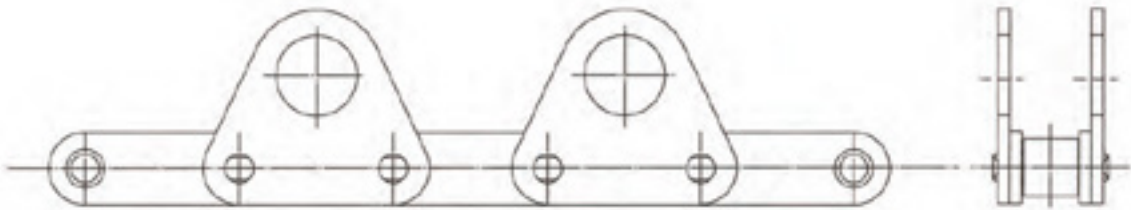
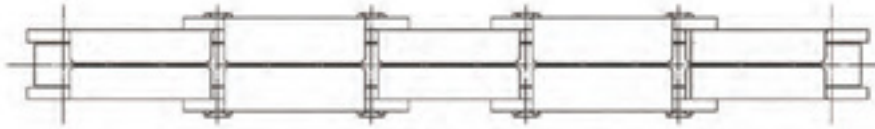
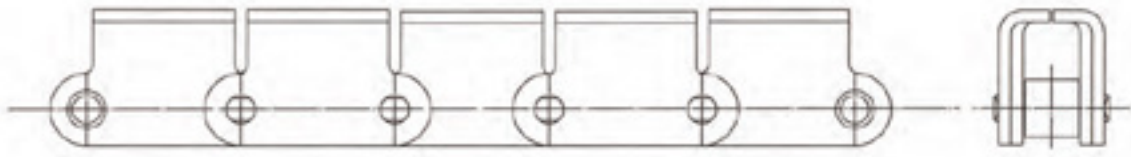

# Double Pitch Chain Special Attachments Examples

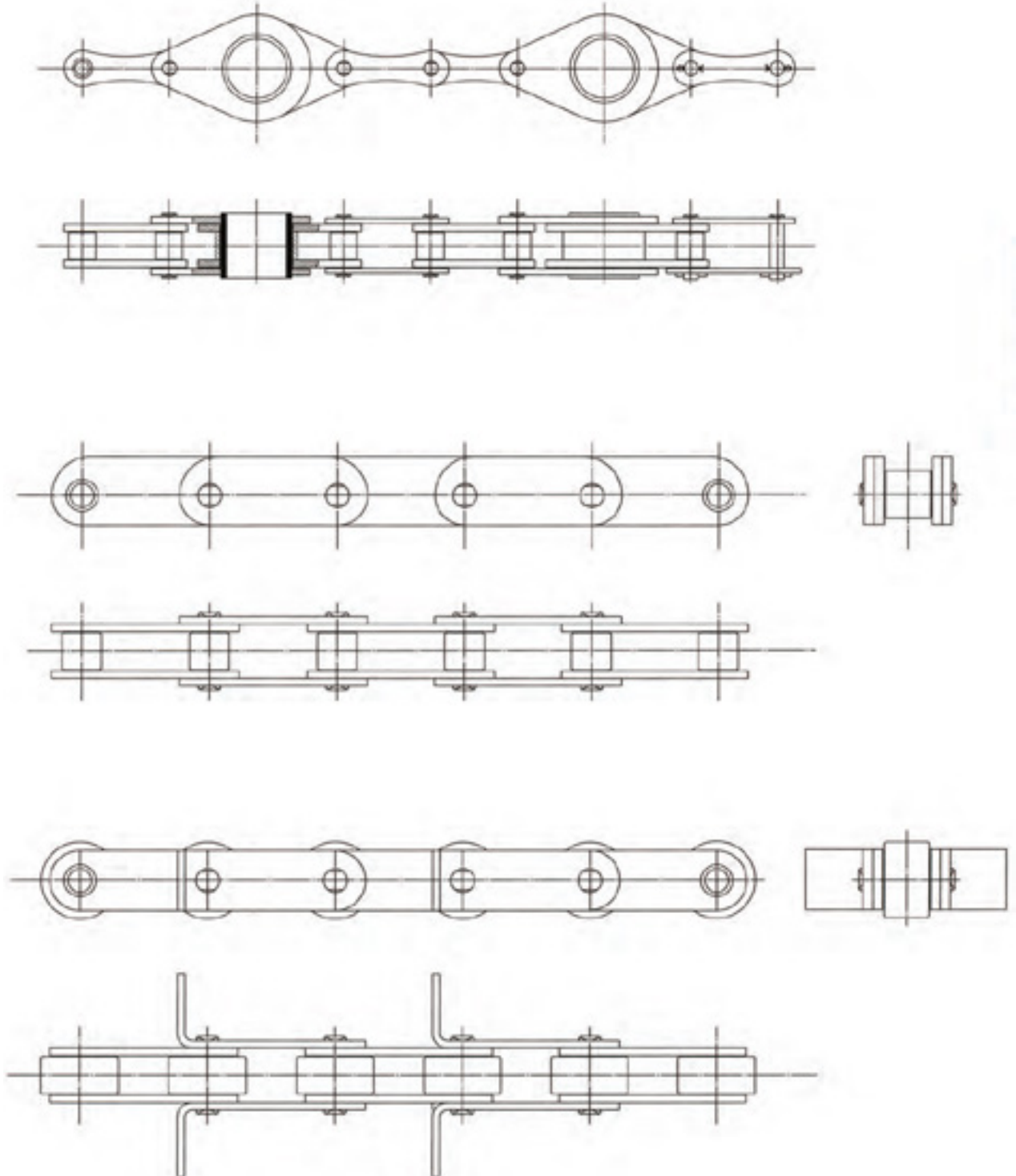

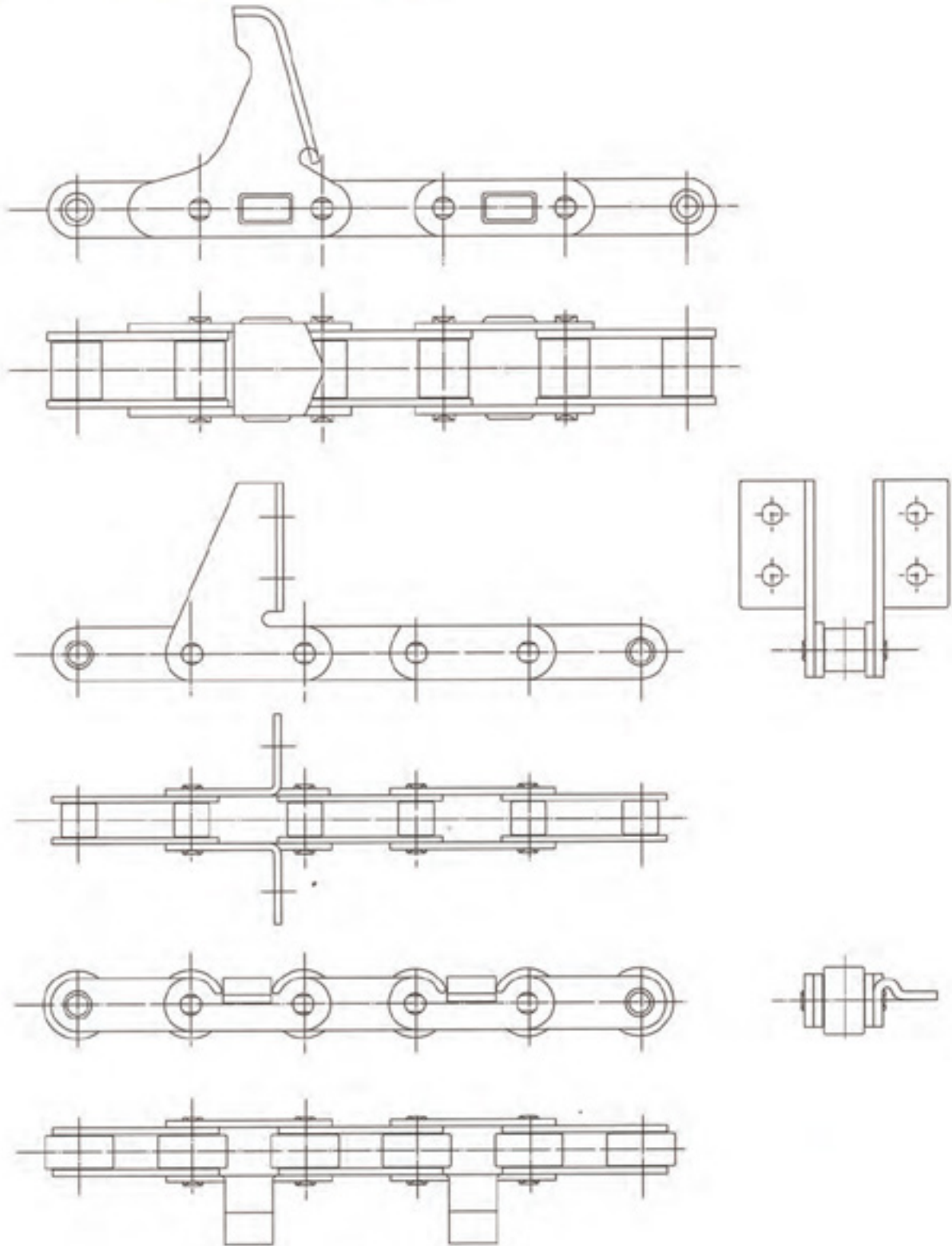



## Double Pitch Chain Special Attachments Examples

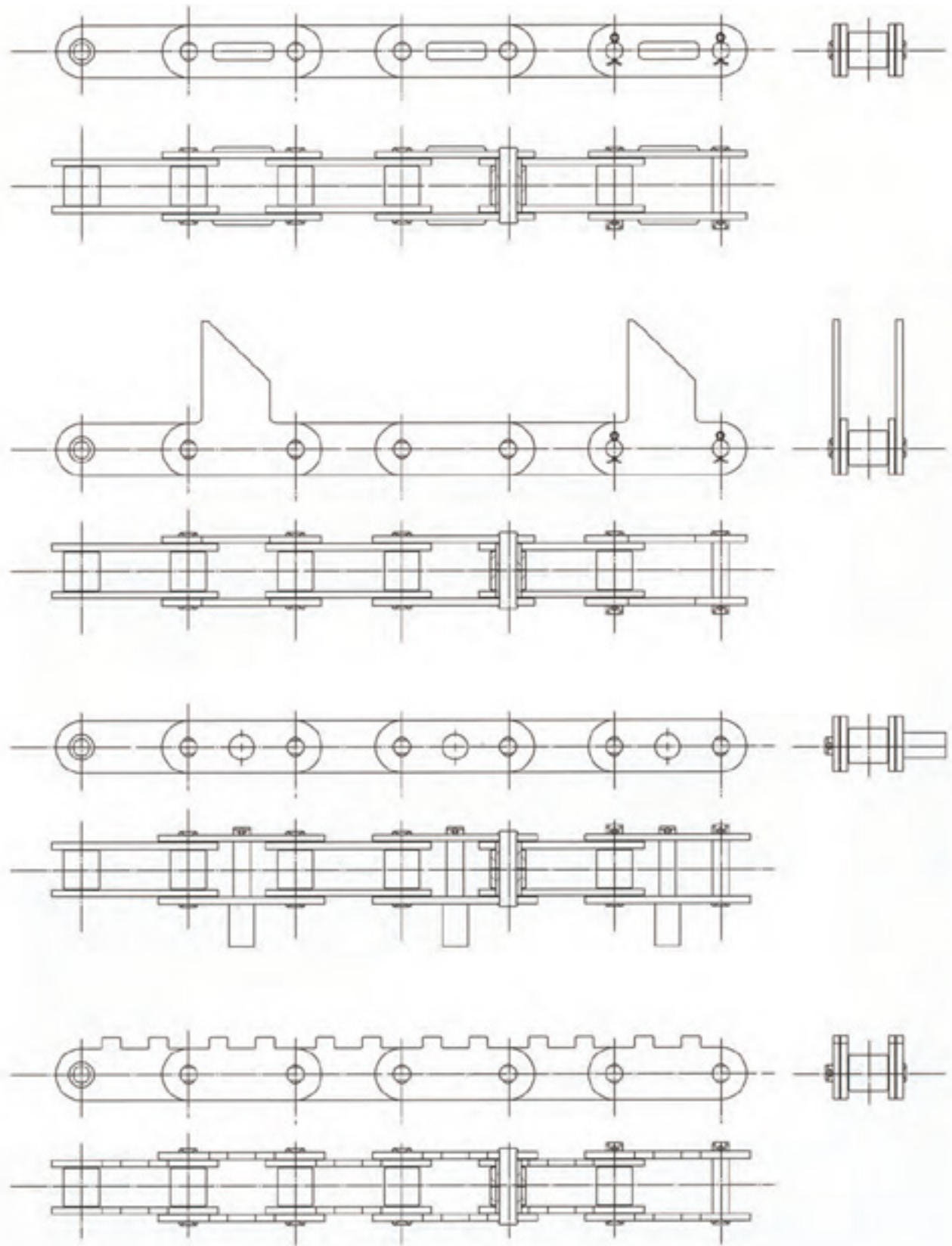

# Accumulation Conveyor Chain

Also known as a top roller chain, this type of chain allows for direct placement of loads on the top rollers. By attaching a stopper to the conveyor, loads can be temporarily halted or stored while the chain continues to run continuously.

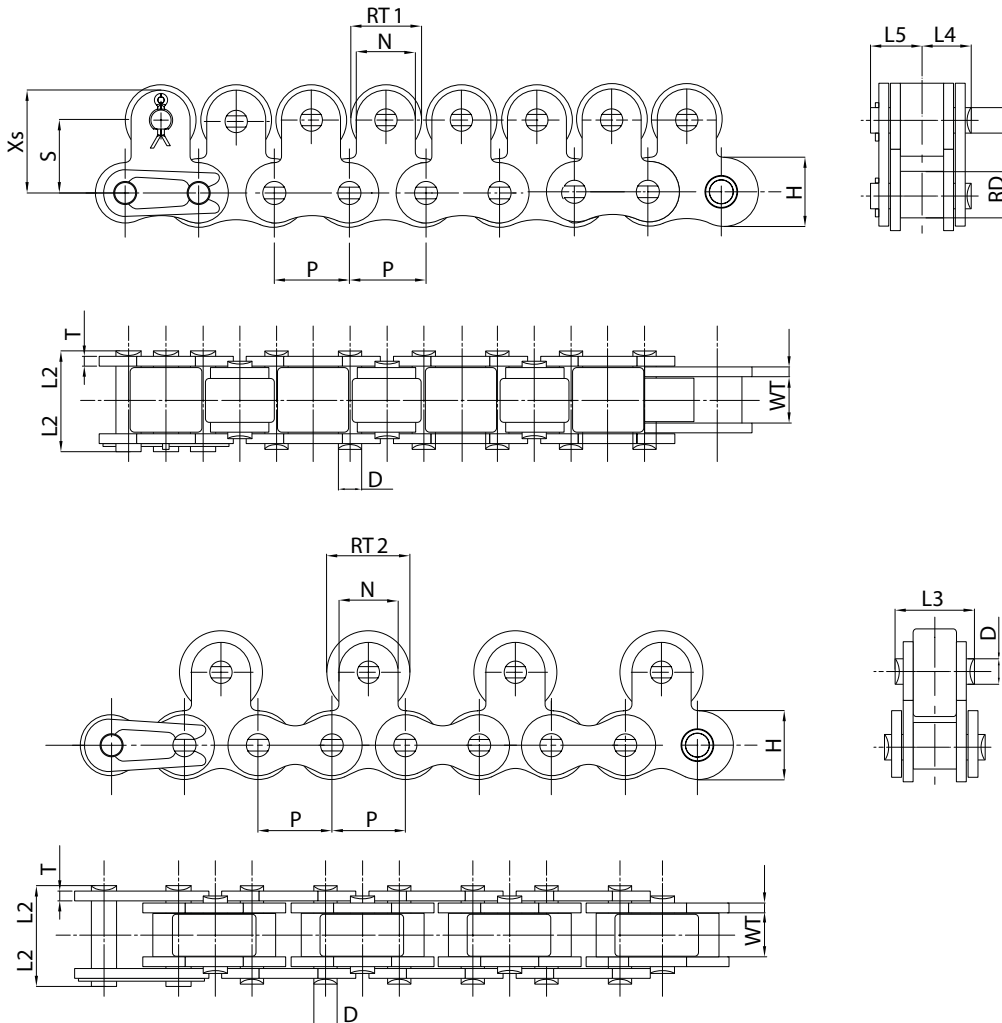

Chain No.	Pitch P mm	Width Between Inner Plates W min mm	Roller Diameter R max mm	Pin Diameter D max mm	Pin Length		Plate Dimensions		kg/m	
					L1 max mm	L2 max mm	H max mm	T max mm	At Every Link	At Every Second Link
40TOP	12.7	7.95	7.94	3.97	8.25	9.95	12.00	1.50	1.83	1.41
50TOP	15.875	9.53	10.16	5.09	10.30	12.00	15.00	2.03	2.39	2.18
60TOP	19.05	12.70	11.91	5.96	12.85	14.75	18.10	2.40	3.60	3.18
80TOP	25.40	15.88	15.88	7.94	16.25	19.25	24.10	3.20	6.09	5.27
100TOP	31.75	19.05	19.05	9.54	19.75	22.85	30.10	4.00	9.30	8.85

Chain No.	Top roller		S mm	N mm	Xs mm	L3 mm	L4 mm	L5 mm	d
	RT1 mm	RT2 mm							
40TOP	11.00	15.88	12.70	9.50	17.45	13.20	8.25	9.65	3.97
50TOP	15.00	19.05	15.90	12.70	22.25	16.20	10.30	11.90	5.09
60TOP	18.00	22.23	18.30	15.90	26.25	20.60	12.85	15.25	5.96
80TOP	24.00	28.58	24.60	19.10	34.15	25.70	16.25	19.25	7.94
100TOP	30.00	39.69	31.80	25.40	44.50	31.00	19.75	22.85	9.54

# Double Pitch Accumulation Chain

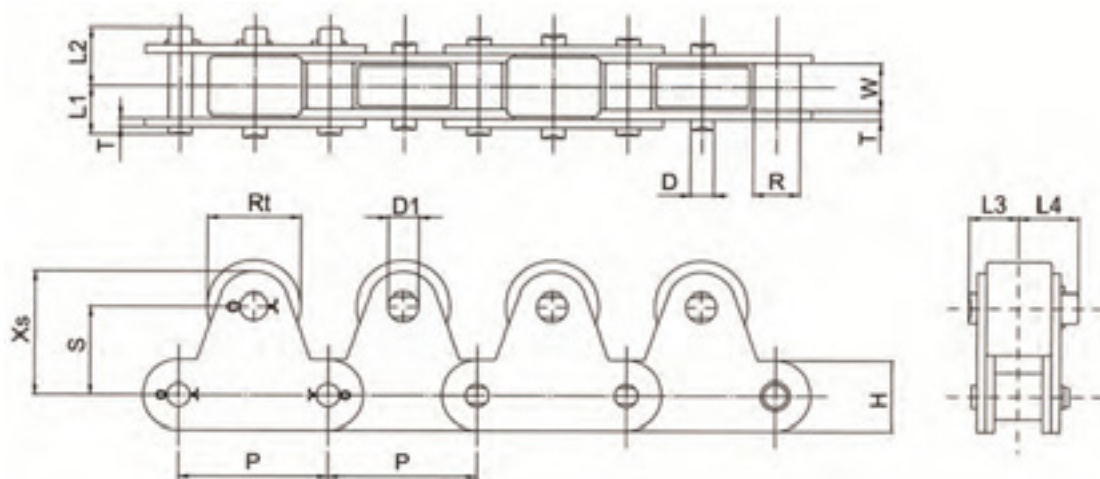

ANSI Chain No.	Pitch P mm	Roller Diameter R max mm	Width Between Inner Plates W min mm	Pin Diameter D max mm	Pin Length		Plate Dimensions		Weight Per Metre kg/m
					L1 max mm	L2 max mm	H max mm	T max mm	
2040TOP	25.40	7.92	7.85	3.98	8.90	9.95	12.07	1.50	1.35
2050TOP	31.75	10.16	9.40	5.09	10.90	12.00	15.09	2.03	2.06
2060TOP	38.10	11.91	12.57	5.96	13.4	14.75	18.08	3.25	3.70
2082TOP	50.80	15.88	15.75	7.94	16.75	19.25	24.13	4.00	5.68
2100TOP	63.50	19.05	18.90	9.54	20.55	22.85	30.18	4.80	9.15
2042TOP	25.40	15.88	7.85	3.98	8.90	9.95	12.07	1.50	1.72
2052TOP	31.75	19.05	9.40	5.09	10.90	12.00	15.09	2.03	2.56
2062TOP	38.10	22.23	12.57	5.96	13.45	14.75	18.08	3.25	4.38
2082TOP	50.80	28.58	15.75	7.94	16.75	19.25	24.13	4.00	6.80
2102TOP	63.50	39.67	18.90	9.54	20.55	22.85	30.18	4.08	11.42

ANSI Chain No.	Other dimensions					
	Rt mm	S mm	Xs mm	L3 mm	L4 mm	D1 mm
2040TOP	15.88	15.00	21.00	8.45	10.05	5.20
2050TOP	19.05	19.00	26.50	10.50	12.90	6.10
2060TOP	22.23	23.00	31.60	14.75	17.75	8.07
2082TOP	28.58	29.00	40.50	18.50	21.30	11.32
2100TOP	39.67	35.40	49.70	22.10	27.20	14.52
2142TOP	15.88	15.00	21.00	8.45	10.05	5.20
2152TOP	19.05	19.00	26.50	10.50	12.90	6.10
2162TOP	22.23	23.00	31.60	14.75	17.75	8.07
2182TOP	28.58	29.00	40.50	18.50	21.30	11.32
2102TOP	39.67	35.40	49.70	22.10	27.20	14.52

# Side Roller Chain

Side roller chains are renowned for their exceptionally smooth operation. The rollers can be installed in either a parallel or alternative pattern, providing versatility for different applications. Plastic rollers can be used providing effective noise reduction, ensuring quieter operation.

## Alternative type

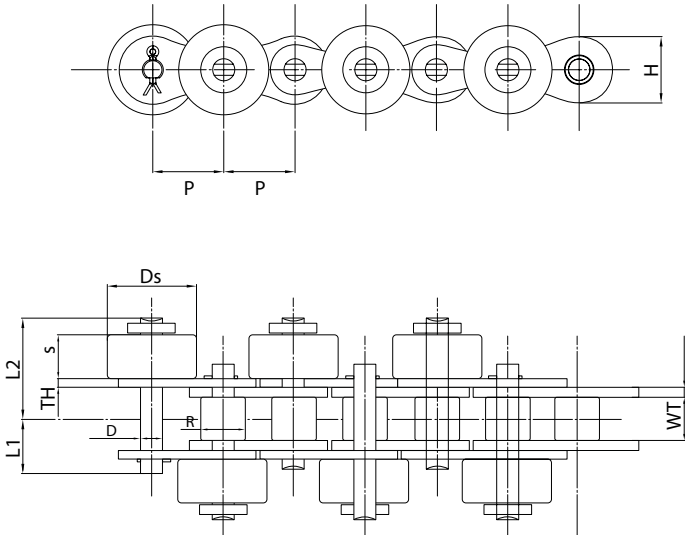

## Parallel type

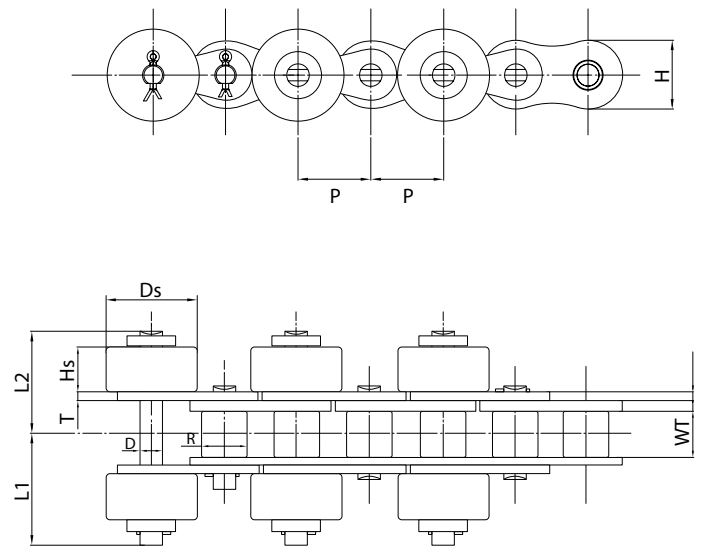

Chain No.	Pitch P mm	Roller Diameter R min mm	Width Between Inner Plates W max mm	Pin Diameter D max mm	Plates Thickness T max mm	Inner Plate Depth H max mm	Pin Length			Outboard Roller		Weight Per Metre kg/m
							L1 max mm	L2 max mm	L3 max mm	Ds max mm	Hs max mm	
40	12.70	7.92	7.85	3.98	1.50	12.07	9.95	18.00	19.50	15.88	7.80	1.85
50	15.875	10.16	9.40	5.09	2.03	15.09	12.00	21.80	23.50	19.05	9.40	2.64
60	19.05	11.91	12.57	5.96	2.42	18.08	14.75	28.00	30.60	22.23	12.60	3.85
80	25.40	15.88	15.75	7.94	3.25	24.13	19.25	35.20	38.20	28.58	15.80	6.16
100	31.75	19.05	18.90	9.54	4.00	30.18	22.85	43.00	45.90	39.69	19.00	10.22
C2040	25.40	7.92	7.85	3.98	1.50	12.07	9.95	18.00	19.50	15.88	7.80	1.08
C2042		15.88										2.07
C2050	31.75	10.16	9.40	5.09	2.03	15.09	12.00	21.80	23.50	19.05	9.40	1.55
C2052		19.05										2.88
C2060	38.10	11.91	12.57	5.96	3.25	18.08	17.40	29.85	32.25	22.23	12.60	2.65
C2062		22.23										3.96
C2080	50.80	15.88	15.75	7.94	4.00	24.13	21.30	36.85	39.85	28.58	15.80	4.38
C2282		28.58										6.55
C2100	63.50	19.05	18.90	9.54	4.80	30.18	25.55	44.40	47.50	39.69	19.00	7.08
C2102		39.67										11.10

Free Flow Chains are the perfect solution for smooth and damage-free material handling in conveyor systems. Free Flow Chains are specifically designed to stop conveyed objects with a stopper while the chain continues to run underneath. Once the stopper is released, conveying resumes seamlessly. During accumulation, the rollers freely rotate and maintain gentle contact with the bottom side of goods being conveyed, ensuring a smooth and damage-free operation.

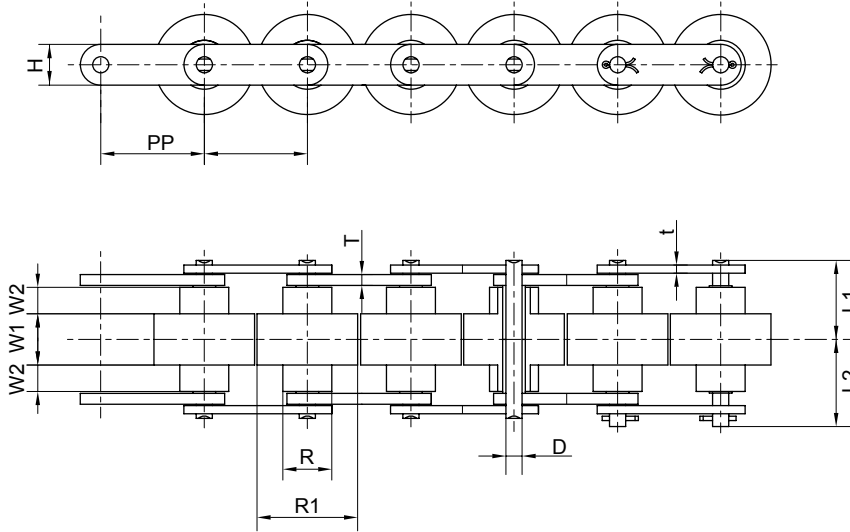

ISO Chain No.	ANSI Chain No.	Pitch P	Roller Measures				Plate Thickness		Plate Depth H max	Pin Diameter D max	Pin Length		Weight Per Metre kg/m
			R max	R1 min	W1 max	W2 max	t max	T max			L1 max	L2 max	
BS25-C2068	HX2030VRP	19.05	11.91	18.30	8.00	4.00	1.50	1.30	8.26	3.28	12.10	15.10	0.66
BS25-C208A	HX2040VRP	25.40	15.88	24.60	10.30	5.70	2.00	1.50	12.07	3.95	16.30	20.20	1.10
BS25-C210A	HX2050VRP	31.75	19.05	30.60	13.00	7.10	2.40	2.00	15.09	5.08	20.10	24.20	1.45
8S25-C212A	HX2060VRP	38.10	22.23	36.60	15.50	8.50	4.00	3.00	18.08	5.94	25.60	30.10	2.13
8S25-C216A	HX2080VRP	50.80	28.58	49.00	21.50	11.00	5.00	4.00	24.13	7.92	33.10	38.50	4.10
8S30-C2068	HX2030VRP-B	19.05	9.00	18.30	9.10	4.50	1.50	1.30	7.28	3.28	13.15	16.45	0.68
8S30-C208A	HX2040VRP-B	25.40	11.91	24.60	12.50	6.10	2.00	1.50	9.60	3.96	17.80	21.70	1.15
8S30-C210A	HX2050VRP-B	31.75	14.80	30.60	15.00	7.50	2.40	2.00	12.20	5.08	22.50	24.60	1.51
BS30-C212A	HX2060VRP-B	38.10	18.00	37.00	20.00	9.75	4.00	3.00	15.00	5.94	29.05	33.65	2.22
8S30-C216A	HX2080VRP-B	50.80	22.23	49.00	25.20	12.00	5.00	4.00	18.00	7.92	35.95	41.35	4.26

Plastic Roller Type Size Chart (mm).

Free Flow Chains are the perfect solution for smooth and damage-free material handling in conveyor systems. Free Flow Chains are specifically designed to stop conveyed objects with a stopper while the chain continues to run underneath. Once the stopper is released, conveying resumes seamlessly. During accumulation, the rollers freely rotate and maintain gentle contact with the bottom side of goods being conveyed, ensuring a smooth and damage-free operation.

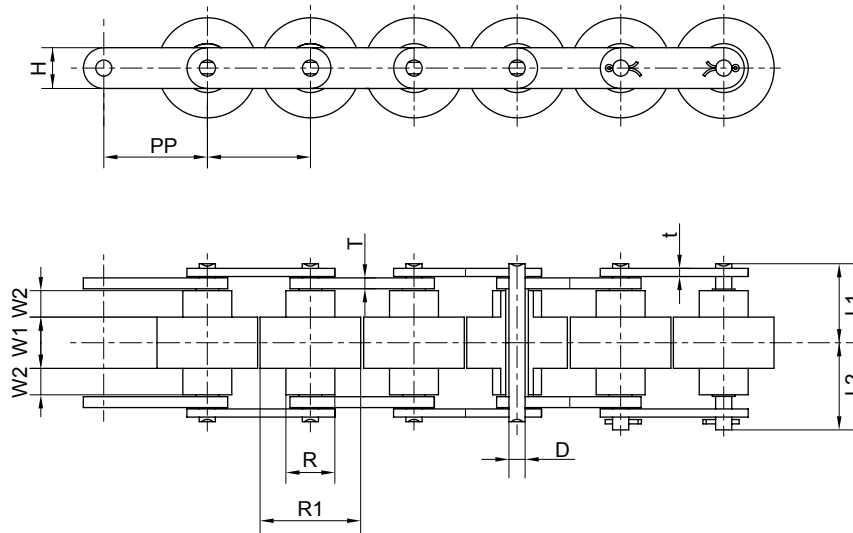

ANSI Chain No.	Pitch P	Roller Measures				Plate Thickness		Plate Depth H max	Pin Diameter D max	Pin Length		Weight Per Metre kg/m
		R max	R1 min	W1 max	W2 max	t max	T max			L1 max	L2 max	
HX2030VR	19.05	11.91	18.30	8.00	4.00	1.50	1.30	8.26	3.28	12.10	15.40	1.45
HX2040VR	25.40	15.88	24.60	10.30	5.70	2.00	1.50	12.07	3.96	16.30	20.20	2.60
HX2050VR	31.75	19.05	30.60	13.00	7.10	2.40	2.00	15.09	5.08	20.10	24.20	3.80
HX2060VR	38.10	22.23	36.60	15.50	8.50	4.00	3.00	18.08	9.94	25.60	30.10	5.60
HX2080VR	50.80	28.58	49.00	21.50	11.00	5.00	4.00	24.13	7.92	33.10	38.50	10.53
HX2030VR-B	19.05	9.00	18.30	9.10	4.50	1.50	1.30	7.28	3.28	13.15	16.45	1.52
HX2040VR-B	25.40	11.91	24.60	12.50	6.10	2.00	1.50	9.60	3.96	17.80	21.70	2.73
HX2050VR-B	31.75	14.80	30.60	15.00	7.50	2.40	2.00	12.20	5.08	22.50	24.60	4.00
HX2060VR-B	38.10	18.00	37.00	20.00	9.75	4.00	3.00	15.00	5.94	29.05	33.65	5.88
HX2080VR-B	50.80	22.23	49.00	25.50	12.00	5.00	4.00	18.60	7.92	35.95	41.35	11.06

Steel Roller Type Size Chart (mm).

# Leaf Chains

The simplest of steel chains, consisting only of link plates and pins. This chain has a greater tensile strength than roller chains and run over sheaves rather than sprockets.

Suitable for hoisting, hanging, balancing, dragging or motion transmitting applications. Leaf chains are often used as counterweight chains for machine tools, elevator and oven doors, fork lift truck masts, spinning frames and similar lifting or balancing applications. Plates are connected by pins and hold the tension loaded on the chain.

## Our range

- ▶ AL Series
- ▶ LL / EL Series
- ▶ BL / LH Series
- ▶ FL Series
- ▶ Galle Chain
- ▶ Rollerless



# AL Series Leaf Chain

AL series (American Light) chain (manufactured to the ANSI B29.9 standard) is constructed from American standard roller chain components. AL series chain is lightweight chain used for light load lifting applications and machine tools. Plate configuration and thickness are the same as ANSI roller chain. Pin diameter is almost the same as ANSI roller chain.

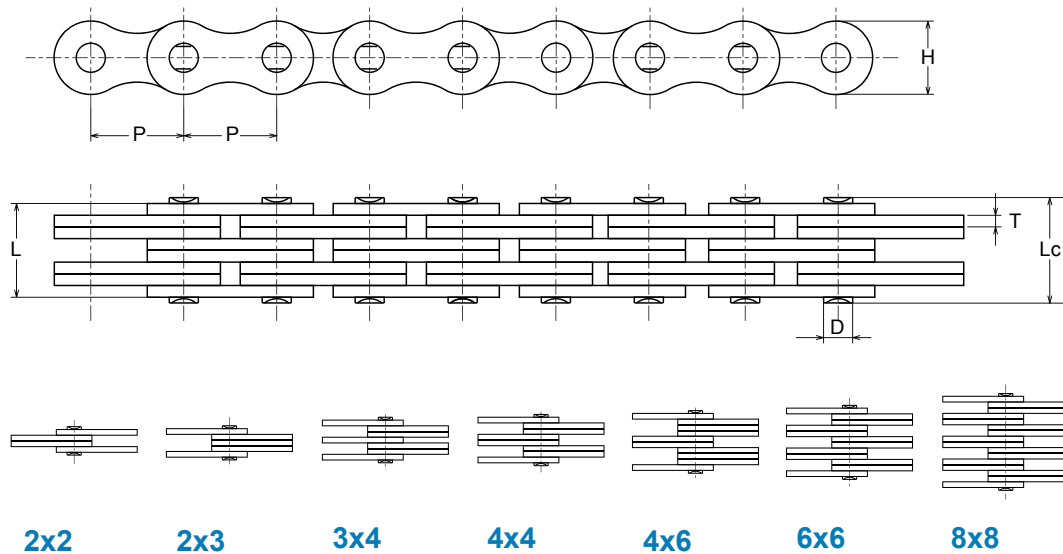

ANSI Chain No.	Pitch P mm	Lacing	Plate Depth h2 min mm	Plate Thickness T mm	Pin Diameter d2 max mm	Pin Length L max mm	Tensile Strength		Weight Per Metre q = kg/m
							Ultimate Q min mm	Average Q0 mm	
AL422	12.70	2 x 2	10.40	1.50	3.96	7.90	14.10	16.90	0.39
AL444		4 x 4				14.40	28.20	35.20	0.74
AL466		6 x 6				20.50	42.30	52.70	1.10
AL522	15.88	2 x 2	12.80	2.06	5.08	10.30	22.00	27.50	0.61
AL544		4 x 4				18.90	44.00	55.00	1.19
AL566		6 x 6				26.90	66.00	82.50	1.79
AL622	19.05	2 x 2	15.60	2.44	5.94	12.40	37.00	44.40	0.86
AL644		4 x 4				22.70	64.00	76.80	1.69
AL666		6 x 6				32.40	101.00	121.20	2.52
AL822	25.40	2 x 2	20.50	3.26	7.92	16.00	56.70	68.60	1.54
AL844		4 x 4				29.40	113.40	135.60	3.00
AL866		6 x 6				42.50	170.00	202.30	4.46
AL1022	31.75	2 x 2	25.60	4.00	9.53	19.60	88.50	107.10	2.37
AL1044		4 x 4				35.90	177.00	203.60	4.68
AL1066		6 x 6				52.30	265.00	315.80	7.00
AL1222	38.10	2 x 2	30.50	4.80	11.10	24.30	127.00	151.10	3.65
AL1244		4 x 4				43.80	254.00	299.70	7.05
AL1266		6 x 6				63.00	381.00	426.30	10.44
AL1422	44.45	2 x 2	36.40	5.65	12.70	28.07	151.23	182.37	4.79
AL1444		4 x 4				51.30	372.70	413.60	10.34
AL1466		6 x 6				74.56	559.00	620.40	15.16
AL1622	50.80	2 x 2	41.60	6.45	14.27	32.94	191.26	231.13	5.98
AL1644		4 x 4				58.06	471.00	522.80	12.98
AL1666		6 x 6				84.46	706.00	783.60	19.41



# LL / EL Series Leaf Chain

LL / EL series (European Light – Leaf Light) chain, manufactured according to ISO4347, DIN8152 and NFE26107, is constructed from roller chain components to European standard. Like AL series chain, EL-LL series chain is a lightweight chain used for light load lifting applications and machine tools.

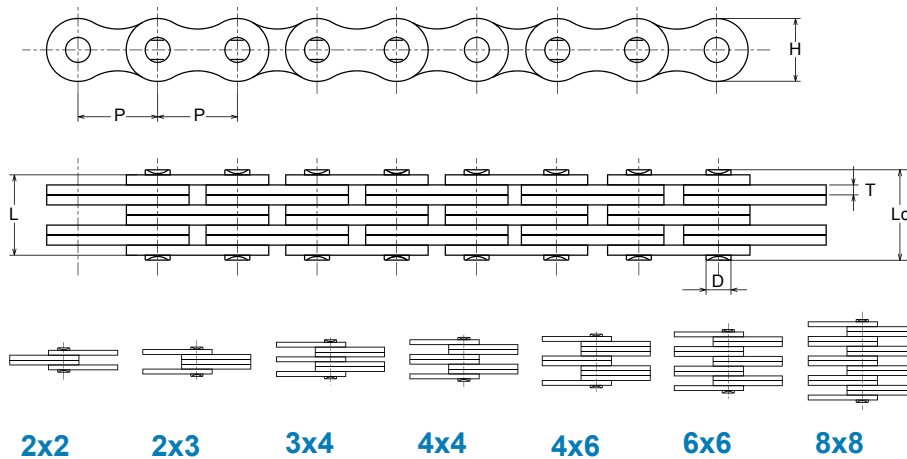

ISO/DIN Chain No.	ANSI Chain No.	Pitch P	Lancing	Plate Thickness		Pin Diameter D max	Pin Length		Ultimate Tensile Strength min kN	Average Tensile Strength kN	Weight Per Metre kg/m
				H max	T max		L max	Lc max			
LL0822	EL0422	12.7	2X2	10.60	1.30	4.45	7.6	9.6	17.8	21.5	0.40
LL0844	EL0444		4X4				13.0	15.0	31.1	36.2	0.80
LL0866	EL0466		6X6				18.2	20.2	44.5	51.2	1.20
LL0888	EL0488		8X8				23.5	25.5	62.2	72.6	1.35
LL1022	EL0522	15.875	2X2	13.70	1.60	5.08	9.2	11.2	22.3	25.6	0.50
LL1044	EL0544		4X4				15.8	17.8	44.5	53.2	1.00
LL1066	EL0566		6X6				22.1	24.1	66.7	78.3	1.50
LL1088	EL0588		8X8				28.8	30.8	89.0	100.3	2.20
LL1222	EL0622	19.05	2X2	16.00	1.85	5.72	10.4	12.9	28.9	35.2	0.70
LL1244	EL0644		4X4				17.9	20.4	57.8	68.0	1.30
LL1266	EL0666		6X6				25.4	27.9	86.7	98.3	2.00
LL1288	EL0688		8X8				32.9	35.4	115.6	135.0	2.88
LL1622	EL0822	25.4	2X2	21.00	3.10	8.28	17.2	20.2	58.0	68.0	1.50
LL1644	EL0844		4X4				29.6	32.6	144.0	166.3	3.00
LL1666	EL0866		6X6				42.4	45.4	200.0	232.8	4.40
LL1688	EL0888		8X8				55.4	58.4	288.0	333.3	5.80
LL2022	EL1022	31.75	2X2	26.40	3.70	10.19	20.1	23.6	95.0	110.8	2.30
LL2044	EL1044		4X4				33.8	37.3	95.0	220.5	4.40
LL2066	EL1066		6X6				50.1	53.6	285.0	325.6	6.60
LL2088	EL1088		8X8				65.4	68.9	380.0	436.2	8.80

LL0822/EL0422 - LL2088/EL1088 Size Chart (mm).

# LL / EL Series Leaf Chain

LL / EL series (European Light – Leaf Light) chain, manufactured according to ISO4347, DIN8152 and NFE26107, is constructed from roller chain components to European standard. Like AL series chain, EL-LL series chain is a lightweight chain used for light load lifting applications and machine tools.

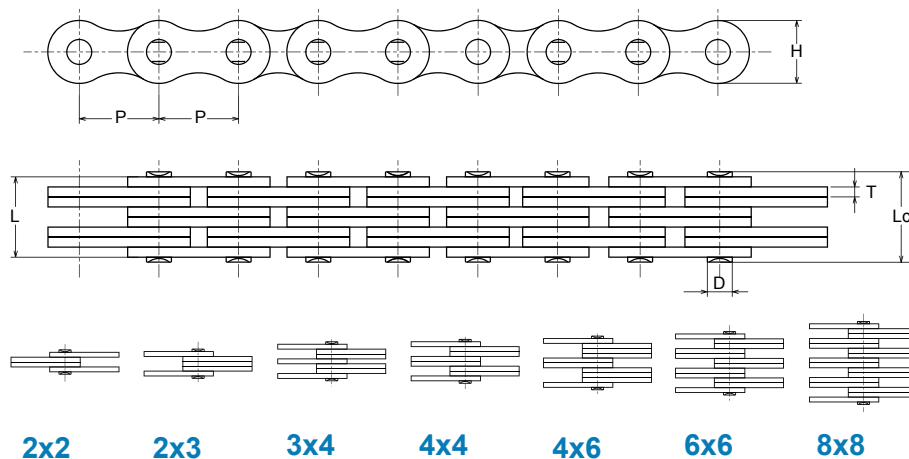

ISO/DIN Chain No.	ANSI Chain No.	Pitch P	Lancing	Plate Thickness		Pin Diameter D max	Pin Length		Ultimate Tensile Strength min kN	Average Tensile Strength kN	Weight Per Metre kg/m
				H max	T max		L max	Lc max			
LL2422	EL1222	38.1	2X2	33.40	5.00	14.63	28.4	33.4	170.0	196.3	4.40
LL2444	EL1244		4X4				46.3	51.3	340.0	380.5	8.50
LL2466	EL1266		6X6				66.4	71.4	510.0	576.8	12.50
LL2488	EL1288		8X8				86.6	91.6	680.0	776.2	17.00
LL2822	EL1422	44.45	2X2	37.08	6.00	15.90	32.2	37.7	200.0	226.2	5.40
LL2844	EL1444		4X4				56.4	61.9	400.0	448.1	10.50
LL2866	EL1466		6X6				80.6	86.1	600.0	675.8	15.50
LL2888	EL1488		8X8				105.2	110.7	800.0	893.8	20.00
LL3222	EL1622	50.8	2X2	42.00	6.00	17.81	33.2	39.2	260.0	298.2	6.20
LL3244	EL1644		4X4				57.4	63.4	520.0	582.5	12.10
LL3266	EL1666		6X6				81.6	87.6	780.0	875.5	18.00
LL3288	EL1688		8X8				105.0	110.0	360.0	432.0	10.33
LL4022	EL2022	63.5	2X2	52.76	8.00	22.89	42.2	48.2	360.0	432.0	10.33
LL4044	EL2044		4X4				74.4	80.4	780.0	936.0	20.03
LL4066	EL2066		6X6				106.6	112.6	1080.0	1300.0	30.05
LL4088	EL2088		8X8				140.0	146.0	1440.0	1730.0	39.13
LL4822	EL2422	76.20	2X2	63.88	10.00	29.24	54.6	64.6	560.0	670.0	18.52
LL4844	EL2444		4X4				92.6	102.6	1120.0	1344.0	35.73
LL4866	EL2466		6X6				133.4	143.4	1680.0	2016.0	53.05
LL4888	EL2488		8X8				174.2	184.2	2240.0	2688.0	70.44

LL2422/EL1222 - LL4888/EL2488 Size Chart (mm).

# BL / LH Series Leaf Chain

BL / LH Series ( Leaf Heavy) leaf chains consist of link plates which are thicker and larger in contour than the AL Series link plates of the same pitch. The link plates have the same thickness as the link plates of the next larger pitch size in ANSI roller chains. The pins have the same diameter as those of ANSI roller chains of the next larger pitch.

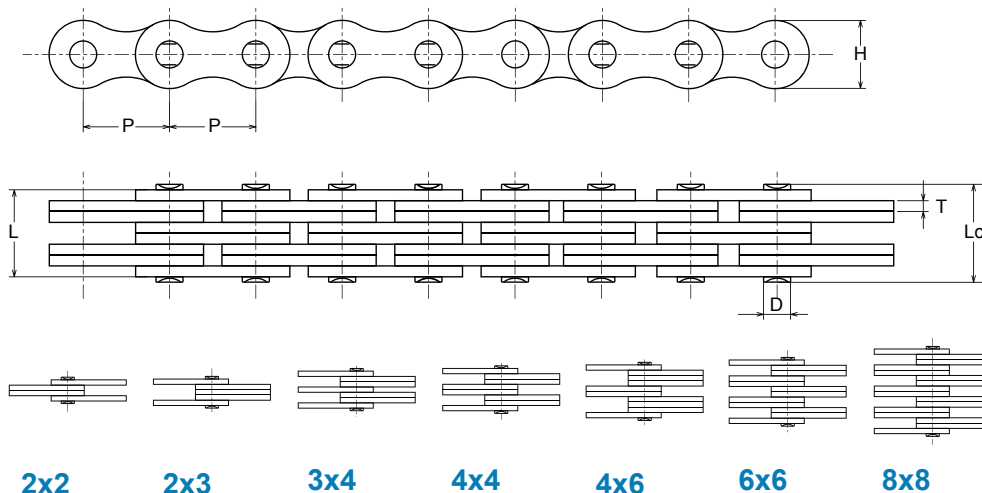

ANSI Chain No.	ISO Chain No.	Pitch P	Lacing	Plate Thickness		Pin Diameter D max	Pin Length		Ultimate Tensile Strength min kN	Average Tensile Strength kN	Weight Per Metre kg/m
				H max	T max		L max	Lc max			
LH0822	BL422	12.7	2X2	12.07	2.08	5.09	11.05	13.05	22.2	28.2	0.64
LH0823	BL423		2X3				13.16	15.16	22.2	28.2	0.80
LH0834	BL434		3X4				17.40	19.40	33.4	42.3	1.12
LH0844	BL444		4X4				19.51	21.51	44.5	58.0	1.28
LH0846	BL446		4X6				23.75	25.75	44.5	58.0	1.60
LH0866	BL466		6X6				27.99	29.99	66.7	82.6	1.92
LH0888	BL488		8X8				36.45	38.45	89.0	110.5	2.56
LH1022	BL522	15.875	2X2	15.09	2.44	5.96	12.90	15.40	33.4	45.2	0.88
LH1023	BL523		2X3				15.37	17.87	33.4	45.2	1.10
LH1034	BL534		3X4				20.32	22.82	48.9	66.8	1.50
LH1044	BL544		4X4				22.78	25.28	66.7	86.8	1.80
LH1046	BL546		4X6				27.74	30.24	66.7	86.5	2.20
LH1066	BL566		6X6				32.69	35.19	100.1	125.5	2.65
LH1088	BL588		8X8				42.57	45.07	133.4	170.5	3.50
LH1222	BL622	19.05	2X2	18.11	3.3	7.94	17.37	20.37	48.9	65.8	1.45
LH1223	BL623		2X3				20.73	23.73	48.9	65.8	1.80
LH1234	BL634		3X4				27.43	30.43	75.6	100.0	2.50
LH1244	BL644		4X4				30.78	33.78	97.9	122.6	2.90
LH1246	BL646		4X6				37.49	40.49	97.9	122.6	3.60
LH1266	BL666		6X6				44.20	47.20	146.8	195.3	4.30
LH1288	BL688		8X8				57.61	60.61	195.7	240.8	5.80

LH0822/BL422 - LH1288/BL688 Size Chart (mm).

BL / LH Series ( Leaf Heavy) leaf chains consist of link plates which are thicker and larger in contour than the AL Series link plates of the same pitch. The link plates have the same thickness as the link plates of the next larger pitch size in ANSI roller chains. The pins have the same diameter as those of ANSI roller chains of the next larger pitch.

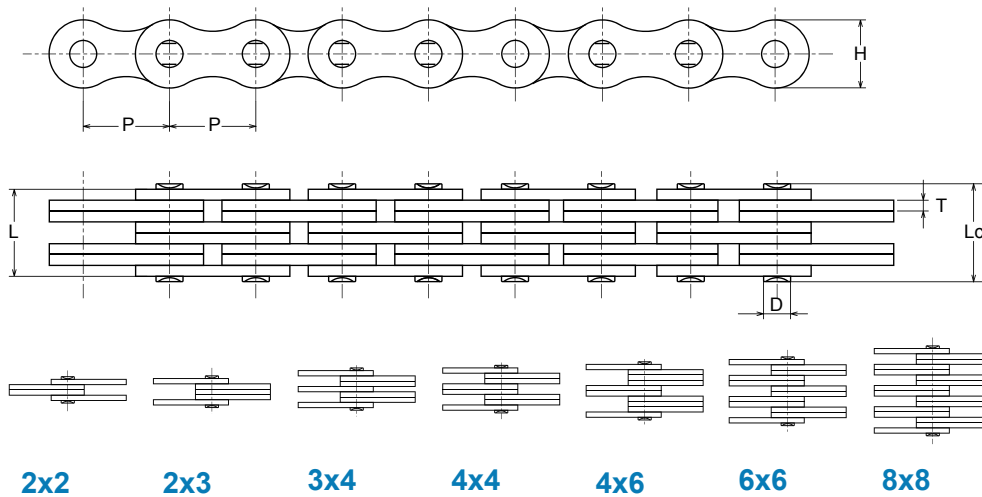

ANSI Chain No.	ISO Chain No.	Pitch P	Lancing	Plate Thickness		Pin Diameter D max	Pin Length		Ultimate Tensile Strength min kN	Average Tensile Strength kN	Weight Per Metre kg/m
				H max	T max		L max	Lc max			
LH1622	BL822	25.4	2X2	24.13	4.09	9.54	21.34	24.84	84.5	110.5	2.20
LH1623	BL823		2X3				25.48	28.98	84.5	110.5	2.70
LH1634	BL834		3X4				33.76	37.26	129.0	175.8	3.80
LH1644	BL844		4X4				37.90	41.40	169.0	220.2	4.30
LH1646	BL846		4X6				46.10	49.68	169.0	220.2	5.40
LH1666	BL866		6X6				54.45	57.96	253.6	326.8	6.50
LH1688	BL888		8X8				71.02	74.52	338.1	438.1	8.60
LH2022	BL1022	31.75	2X2	30.48	4.90	11.11	25.37	29.37	115.6	152.0	3.4
LH2023	BL1023		2X3				30.33	34.33	115.6	152.0	4.3
LH2034	BL1034		3X4				40.23	44.23	182.4	235.2	6.0
LH2044	BL1044		4X4				45.19	49.19	231.3	290.8	6.9
LH2046	BL1046		4X6				55.09	59.09	231.3	290.8	8.6
LH2066	BL1066		6X6				65.00	69.00	347.0	428.6	10.3
LH2088	BL1088		8X8				84.81	88.81	462.6	503.3	13.8
LH2422	BL1222	38.10	2X2	36.55	5.77	12.71	29.62	34.12	151.2	193.8	4.6
LH2423	BL1223		2X3				35.43	39.93	151.2	193.8	5.8
LH2434	BL1234		3X4				47.07	51.57	244.6	316.0	8.1
LH2444	BL1244		4X4				52.88	57.38	302.5	383.0	9.3
LH2446	BL1246		4X6				64.52	69.02	302.5	383.0	11.6
LH2466	BL1266		6X6				76.15	80.65	453.7	545.6	13.9
LH2488	BL1288		8X8				99.42	103.92	605.0	728.0	18.6

LH1622/BL822 - LH2488/BL1288 Size Chart (mm).

# BL / LH Series Leaf Chain

BL / LH Series ( Leaf Heavy) leaf chains consist of link plates which are thicker and larger in contour than the AL Series link plates of the same pitch. The link plates have the same thickness as the link plates of the next larger pitch size in ANSI roller chains. The pins have the same diameter as those of ANSI roller chains of the next larger pitch.

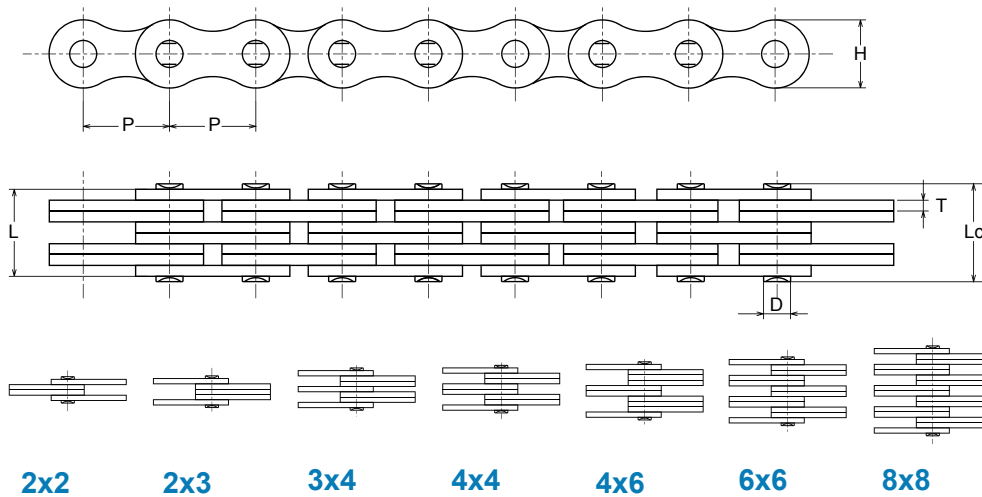

ANSI Chain No.	ISO Chain No.	Pitch P	Lancing	Plate Thickness		Pin Diameter D max	Pin Length		Ultimate Tensile Strength min kN	Average Tensile Strength kN	Weight Per Metre kg/m															
				H max	T max		L max	Lc max																		
LH2822	BL1422	44.45	2X2	42.74	6.55	14.29	33.55	38.55	191.3	226.6	6.1															
LH2823	BL1423		2X3				40.16	45.16				191.3	226.6	7.6												
LH2834	BL1434		3X4				53.37	58.37							315.8	375.5	10.6									
LH2844	BL1444		4X4				59.97	64.97										382.6	453.3	12.2						
LH2846	BL1446		4X6				73.18	78.18													382.6	453.3	15.2			
LH2866	BL1466		6X6				86.39	91.39																578.3	680.8	18.2
LH2888	BL1488		8X8				112.8	117.8																		
LH3222	BL1622	50.8	2X2	48.74	7.52	17.46	39.01	45.01	289.1	343.6	8.0															
LH3223	BL1623		2X3				46.58	52.58				289.1	343.6	10.0												
LH3234	BL1634		3X4				61.72	67.72							440.4	520.8	14.0									
LH3244	BL1644		4X4				69.29	75.29										578.3	682.3	16.0						
LH3246	BL1646		4X6				84.43	90.43													578.3	682.3	20.0			
LH3266	BL1666		6X6				99.57	105.57																857.4	988.6	24.0
LH3288	BL1688		8X8				129.84	135.84																		
LH4022	BL2022	63.5	2X2	60.33	9.91	23.81	51.74	60.0	433.7	520.0	15.9															
LH4023	BL2023		2X3				61.70	69.7				433.7	520.0	20.0												
LH4034	BL2034		3X4				81.61	89.61							649.4	780.0	27.8									
LH4044	BL2044		4X4				91.57	99.57										867.4	1040.5	31.8						
LH4046	BL2046		4X6				111.48	119.5													867.4	1040.5	40.0			
LH4066	BL2066		6X6				131.40	139.4																1301.1	1560.0	47.5
LH4088	BL2088		8X8				171.22	179.22																		

LH2822/BL1422 - LH4088/BL2088 Size Chart (mm).

An earlier style and less commonly used leaf chain. The FL / FLC leaf chain is a light duty that uses single interlacing. It is most commonly used in the UK and to a lesser extent in Europe.

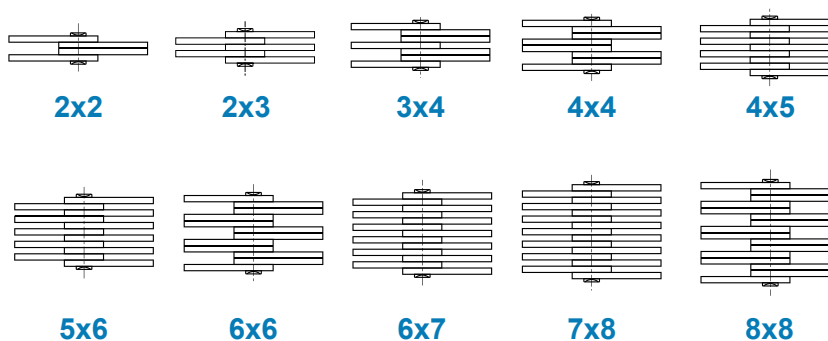
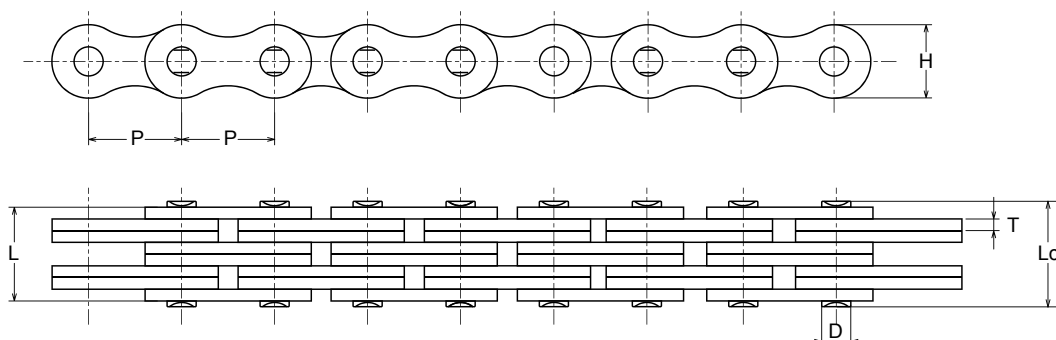

Chain No.	Pitch P mm	Lancing	Plate Depth h2 max mm	Plate Thickness T max mm	Pin Diameter d2 max mm	Pin Length L max mm	Ultimate Tensile Strength Q min kN/LB	Average Tensile Strength Q0 kN mm	Weight Per Metre q kg/m
FL644	5.940	4X4	4.7	0.60	1.85	6.6	6.5/1477	7.8	0.40
FL666		6X6				9.3	9.75/2216	11.8	0.80
FL688		8X8				12.0	13.0/2955	15.6	1.20
FL523	8.000	2X3	6.3	1.00	2.31	6.7	7.00/1575	7.4	0.50
FL844		4X4	6.9	0.73		7.9	10.0/2273	12.1	1.00
FL944	9.525	4X4	8.7	1.04	3.28	10.4	21.0/4724	24.7	0.43
FL945		4X5				11.5	21.00/4724	23.0	0.50
FL966		6X6				14.9	31.0/7045	36.8	0.65
FL988		8X8				19.0	42.00/9450	46.2	0.87
FL1222	12.700	2X2	8.2	1.00	3.58	7.0	11.43/2598	13.6	0.19
FL1223		2X3	10.2	2.03	4.45	12.8	20.0/4545	23.8	0.61
FL1244		4X4	10.2	1.70	4.45	16.7	44.0/10000	52.3	0.83
FLC534	15.875	3X4	12.7	1.85	5.08	15.3	40.4/9181	44.4	0.99
FLC545		4X5				19.2	51.3/12340	59.7	1.27
FLC556		5X6				22.7	67.6/15363	74.3	1.54
FLC567		6X8				26.8	80.80/18176	89.0	1.82
FLC578		7X8				30.8	90.00/20250	99.0	2.10

Named after their inventor André Galle, the Galle chain is the simplest type of steel link chain. They are used for industrial applications where it is necessary transmit high tensile force with a small circumferential velocity such as hoisting and lifting.

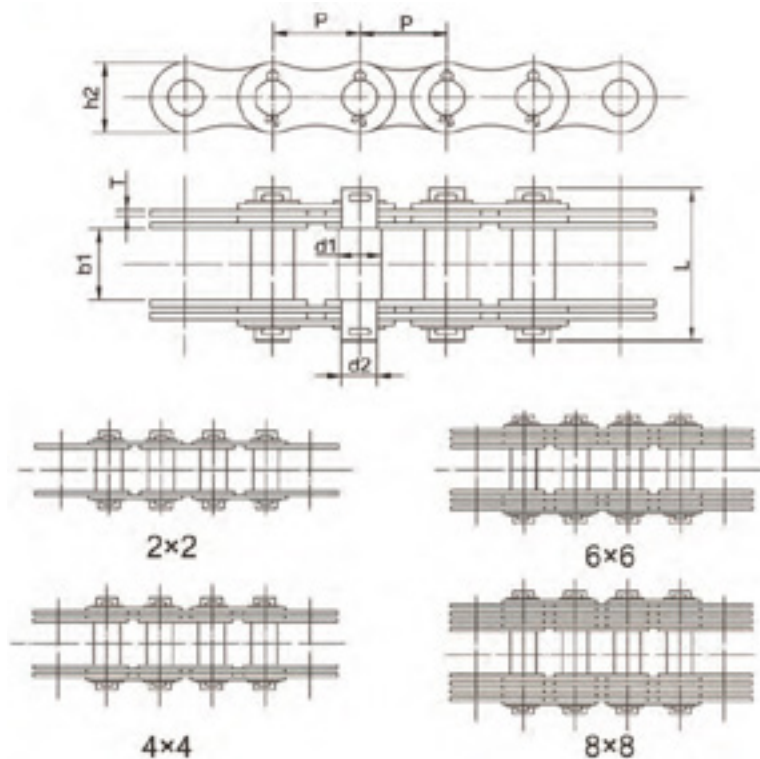

Chain No.	Pitch P mm	Width Between Inner Plates b1 min mm	Lancing	Pin Diameter		Pin Length L max mm	Plate Depth h2 max mm	Plate Thickness T max mm	Ultimate Tensile Strength Q min kN/LB	Weight Per Metre q kg/m
				d1 max mm	d2 max mm					
MP15	15	12	2X2	5	4	28.2	12	2.03	5.0/1125	0.7
MP20	20	15	2X2	8	6	32.0	15	2.03	12.5/2812	1.1
MP25	25	18	2X2	10	8	41.3	18	3.00	25.0/5624	1.8
MP30	30	20	4X4	11	9	57.0	20	3.00	40.0/8999	3.4
MP35	35	22	4X4	12	10	60.0	26	3.00	60.0/13498	4.5
MP40	40	25	4X4	14	12	62.0	32	3.00	80.0/17998	5.0
MP45	45	30	4X4	17	14	72.3	35	3.00	100.0/22497	7.0
MP50	50	35	4X4	22	18	102.0	40	4.50	150.0/33746	11.3
MP55	55	40	4X4	24	21	122.0	42	6.00	200.0/44994	14.5
MP60	60	45	4X4	26	23	129.3	46	6.00	250.0/56243	17.1
MP70	70	50	6X6	32	28	166.6	55	6.00	375.0/84364	34.0
MP80	80	60	6X6	36	32	180.0	60	6.00	500.0/112486	39.0
MP90	90	70	6X6	40	36	208.0	70	7.00	750.0/168728	53.0
MP100	100	80	8X8	45	40	250.6	80	7.00	1000.0/224972	77.0
MP110	110	90	8X8	50	45	266.0	90	7.00	1250.0/281215	90.0
MP120	120	100	8X8	55	50	295.3	100	8.00	1500.0/337458	112.0

## Rollerless Leaf Chain

The rollerless design allows for smaller designs such as 4mm or ANSI 1/4-inch pitch. The rollerless chain is generally used for light loads or those that require only a direct pull.

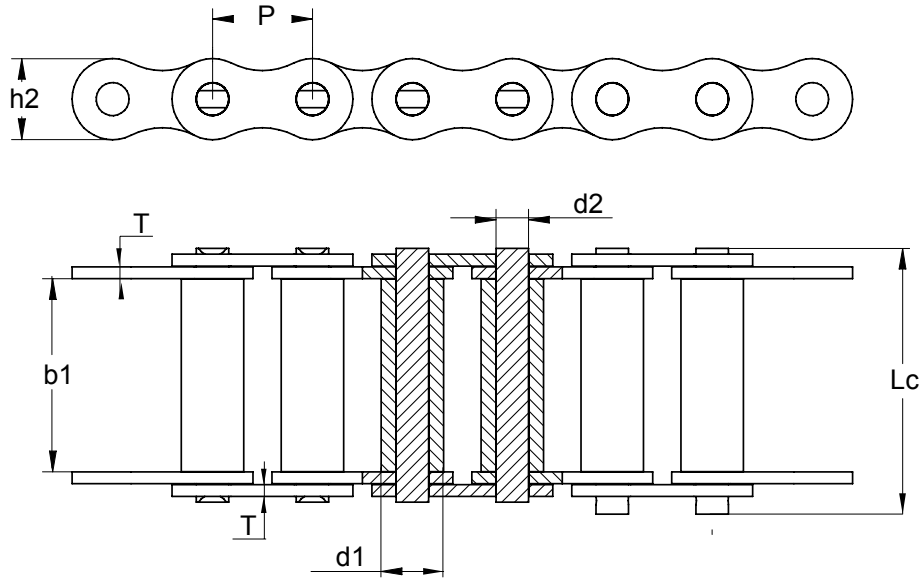

Chain No.	Pitch P mm	Bush Diameter d1 max mm	Width Between Inner Plates b1 max mm	Pin Diameter d2 max mm	Pin Length		Inner Plate Depth h2 max mm	Plate Thickness T max mm	Ultimate Tensile Strength Q min kN	Average Tensile Strength Q0 kN mm	Weight Per Metre q kg/m
					L max mm	Lc max mm					
45-1	12.700	5.63	7.85	3.96	16.60	17.80	12.00	1.50	14.1	17.5	0.54
55-1	15.875	7.03	9.40	5.08	20.70	22.20	15.09	2.03	22.2	29.4	0.83
65-1	19.050	8.33	12.57	5.94	25.90	27.70	18.00	2.42	31.80	41.5	1.22
85-1	25.400	11.10	15.75	7.92	32.70	35.00	24.00	3.25	56.7	69.4	2.16
105-1	31.750	13.60	18.90	9.53	40.40	44.70	30.00	4.00	88.5	109.2	3.31
125-1	38.100	15.60	25.22	11.10	50.30	54.30	35.70	4.80	127.0	156.3	4.97
145-1	44.450	18.00	25.22	12.70	54.40	59.00	41.00	5.60	172.4	212.0	6.50
165-1	50.800	20.00	31.55	14.27	64.80	69.60	47.80	6.40	226.8	278.9	8.70



# Engineered Conveyor Chains

Engineered conveyor chains are designed for applications that require reliable and efficient material handling. These chains are engineered to withstand high loads, operate smoothly, and provide precise control over the movement of materials. They are commonly used in industries such as mining, manufacturing, packaging, food processing, and logistics.

With their robust construction, advanced design features, and extensive range of configurations, conveyor and engineered chains ensure optimal performance and productivity in industrial material handling operations.

## Our range

- ▶ BS Conveyor
- ▶ M Series
- ▶ FV Series
- ▶ SC Series
- ▶ FM Series
- ▶ Solid Pin
- ▶ High Side Plate
- ▶ Hollow Pin
- ▶ Bush Steel
- ▶ Cast Iron
- ▶ Steel Pintel
- ▶ Welded Steel



BS Solid Pin Conveyor Chain

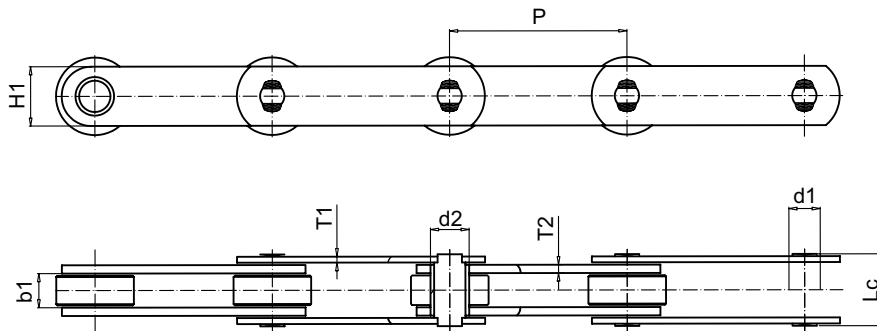

BS Solid Pin Conveyor Chain with Deep Plates

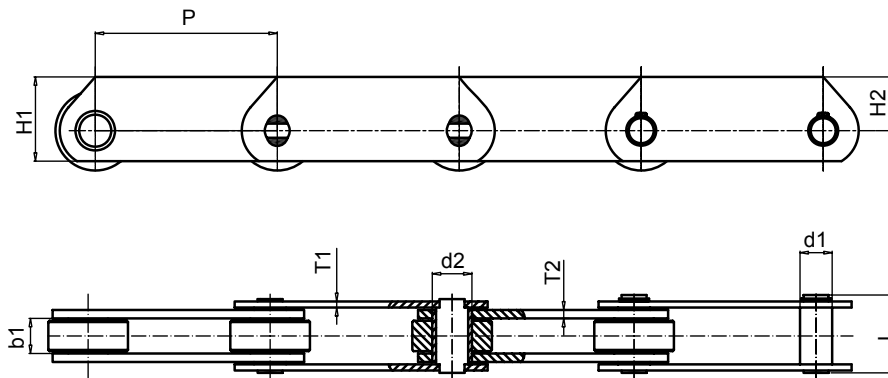

Load Newtons kN	Pitch P		Bush Dia. d2 Max mm	Hollow Bearing Pin Bore Dia. d3 Min mm	Inside Width Inner b1 Min mm	Pin		Plate			
	Min mm	Max mm				Dia. d1 Min mm	Len L Max mm	Height H1 mm	Height H2 mm	Width Outer T1 mm	Width Inner T2 mm
13	25.4	114.3	8.6	—	11.7	5.7	21.8	18.0	16.0	1.8	1.8
33	38.1	152.4	18.0	—	15.0	14.0	38.0	25.4	26.0	3.8	3.8
67	50.8	228.6	23.6	—	19.0	19.0	46.0	38.1	32.0	3.8	5.1
134	88.9	304.8	33.2	—	25.4	26.9	60.0	51.0	45.0	5.1	7.1
200	127.0	457.2	38.1	—	38.1	31.8	82.0	61.0	—	7.6	8.9
367	152.4	457.2	38.1	—	38.1	23.0	80.0	61.0	—	7.6	8.9
400	152.4	609.6	38.1	—	38.1	29.4	94.0	63.5	—	10.0	13.0

BS Conveyor Chain Solid Pin - Chain Size Chart.

**BS Hollow Pin Conveyor Chain**

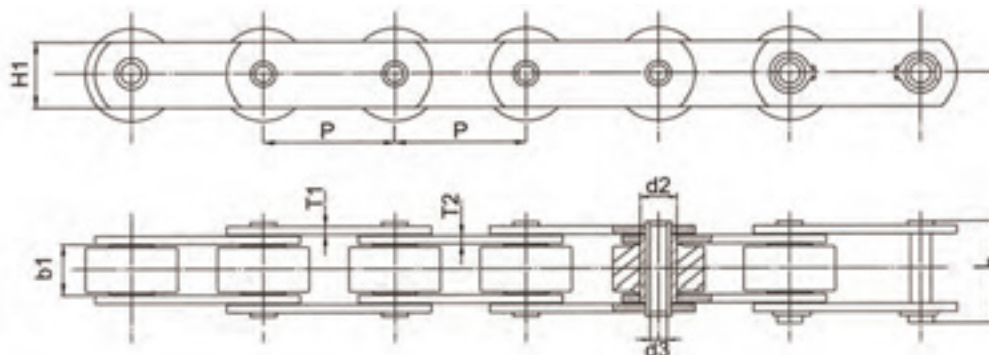

**BS Hollow Pin Conveyor Chain with Deep Plates**

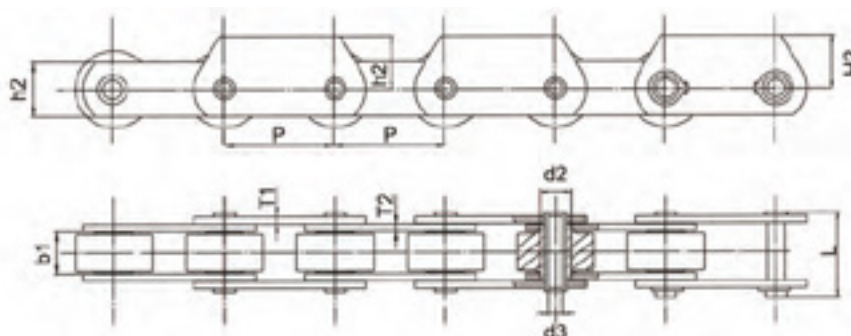

Load Newtons kN	Pitch P		Bush Dia. d2 Max mm	Hollow Bearing Pin Bore Dia. d3 Min mm	Inside Width Inner b1 Min mm	Pin		Plate			
	Min mm	Max mm				Dia. d1 Min mm	Len L Max mm	Height H1 mm	Height H2 mm	Width Outer T1 mm	Width Inner T2 mm
20	38.1	76.2	12.1	6.6	12.7	9.5	24.6	19.1	—	1.8	2.3
27	38.1	152.4	18.0	10.1	15.0	14.0	36.5	25.4	26.0	3.8	3.8
54	50.8	228.6	23.6	13.2	19.0	19.0	44.0	38.1	32.0	3.8	5.1
107	88.9	304.8	33.2	20.1	25.4	26.9	57.0	51.0	45.0	5.1	7.1
160	127.0	457.2	38.1	23.1	38.1	31.8	79.5	61.0	—	7.6	8.9

BS Conveyor Hollow Pin Chain Size Chart.

Rollers

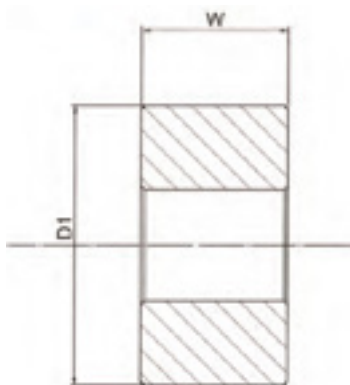

R - Standard Plain

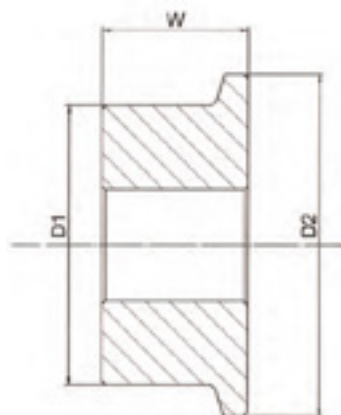

F - Standard Flange

Standard Roller Breaking Load			Standard Plain (R)		Standard Flange (F)			
Hollow Pins kN	Solid Pins kN	Pitch P mm	Tread Diameter D1 mm	Roller Width W mm	Pitch P mm	Tread Diameter D1 mm	Flange Diameter D2 mm	Roller Width W mm
—	13	25.4	12.1	11.4	—	—	—	—
27	33	50.8	31.8	14.0	63.5	31.8	41.3	14.0
54	67	76.2	47.6	17.8	88.9	47.6	60.3	17.8
107	134	101.6	66.7	24.0	114.3	66.7	85.7	24.0
16	200	127.0	88.9	36.8	152.4	88.9	114.3	36.8
—	267	127.0	88.9	36.8	152.4	88.9	114.3	36.8
—	400	152.4	88.9	36.8	165.1	88.9	114.3	36.8

Standard Roller Breaking Load			Standard Plain (R)		Standard Flange (F)			
Hollow Pins kN	Solid Pins kN	Pitch P mm	Tread Diameter D1 mm	Roller Width W mm	Pitch P mm	Tread Diameter D1 mm	Flange Diameter D2 mm	Roller Width W mm
—	13	38.1	25.4	11.4	—	—	—	—
20	—	38.1	25.4	11.4	—	—	—	—
160	200	203.2	127.0	36.8	228.6	127.0	152.4	36.8
—	267	203.2	127.0	36.8	228.6	127.0	152.4	36.8
—	400	203.2	127.0	36.8	228.6	127.0	152.4	36.8

Connecting Links

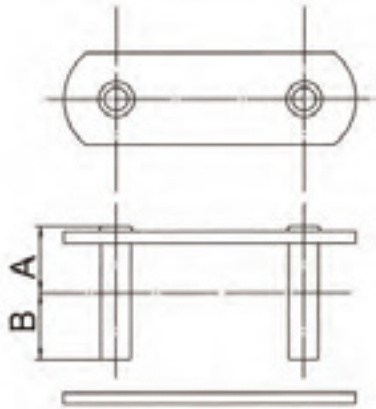

Riveting Link

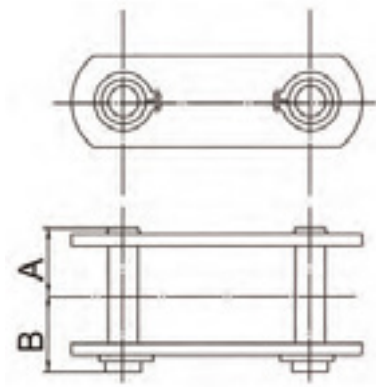

Soft Circlip Link

Standard Roller Breaking Load		Riveting Link		Soft Circlip		Spring Clip Link Both Sides		Link with nuts	
Hollow Pins kN	Solid Pins kN	Hollow Pins A&B mm	Solid Pins A&B mm	A mm	B mm	A mm	B mm	A mm	B mm
—	13	—	11.0	11.0	13.0	—	—	11.0	17.0
20	—	12.3	—	—	—	13.8	13.8	—	—
27	33	18.3	19.0	19.0	22.0	—	—	19.0	30.0
54	67	22.0	23.0	23.0	25.0	—	—	23.0	36.0
107	134	28.5	30.0	—	—	—	—	30.0	46.0
160	200	39.8	41.0	—	—	—	—	41.0	62.0
—	267	—	40.0	—	—	—	—	40.0	56.0
—	400	—	47.0	—	—	—	—	47.0	68.0

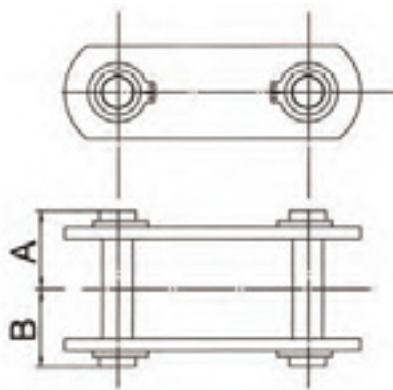

Spring Clip Link Both Sides

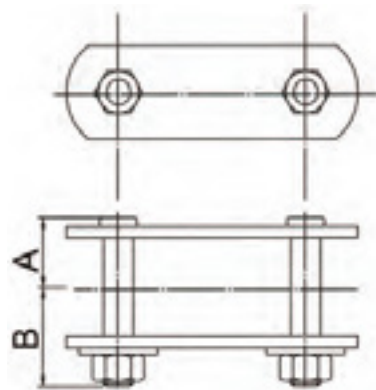

Link with Nuts

# BS Conveyor Chain Attachments

## Integral

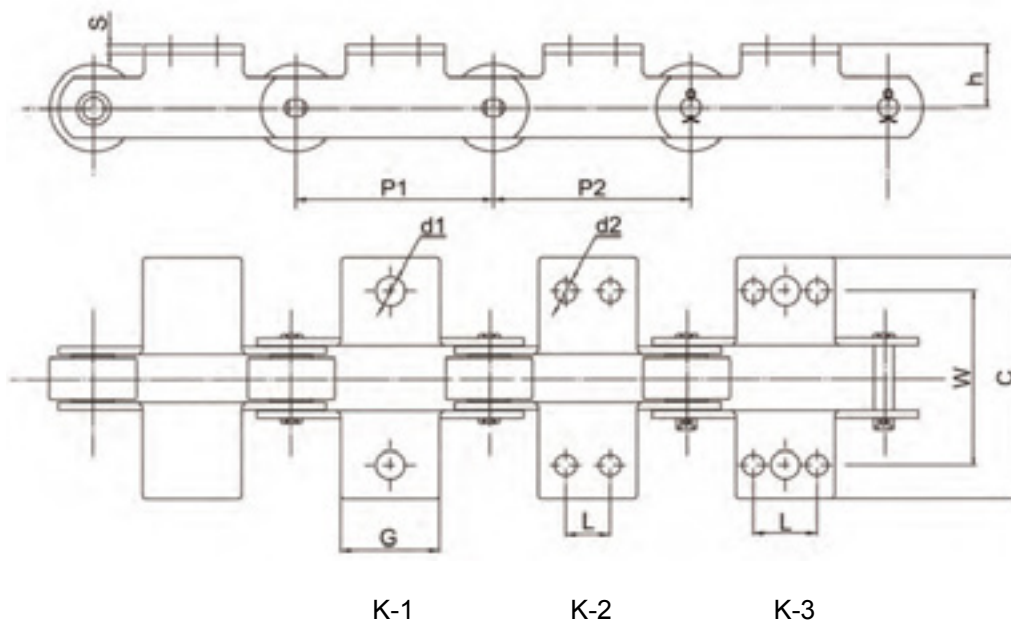

Breaking Load lbf kN	Attachment Face Height h mm	Transverse Pitch W mm	Width Over Attachment Inner/Outer C mm	Attachment Thickness S mm	Attachment Type Inner/Outer	Minimum Pitch		Centre Hole Diameter		Attachment Hole Pitch L mm	Platform Length G mm	Mass kg mm
						Outer Plate P1 mm	Inner Plate P2 mm	d1 mm	d2 mm			
3000	16.5	44.5	66 / 70	1.8	K1	38.1	38.1	9.2	—	—	19.0	0.009
					K3	50.8	50.8	9.2	7.4	25.4	44.5	0.018
						76.2	76.2	9.2	7.4	25.4	44.5	0.018
						101.6	101.6	9.2	7.4	25.4	70.0	0.027
6000 / 7500	19.0	76.2	106 / 115	3.8	K3	76.2	76.2	10.5	9.2	22.2	43.0	0.045
						101.6	101.6	10.5	9.2	31.8	64.0	0.077
						127.0	127.0	10.5	9.2	57.2	89.0	0.109
						152.4	152.4	10.5	9.2	57.2	114.0	0.141
12000 / 15000	31.8	88.9	130 / 136	5.1 / 3.8	K3	76.2	76.2	13.7	10.5	31.8	63.5	0.127
						101.6	101.6	13.7	10.5	31.8	63.5	0.127
24000 / 30000	38.0	108.0	146 / 157	7.1 / 5.7	K3	152.4	152.4	13.7	10.5	57.2	114.5	0.24
					K1	101.6	101.6	15.3	—	—	56.0	0.172
					K2	101.6	101.6	—	12.2	31.8	56.0	0.172
36000 / 45000	50.8	146.0	202 / 198	8.9 / 7.6	K3	152.4	152.4	15.3	12.2	57.2	107.0	0.318
					K2	152.4	152.4	—	13.7	63.5	74.0	0.31
						203.2	203.2	—	13.7	88.9	125.0	0.42

# BS Conveyor Chain Attachments

## Welded

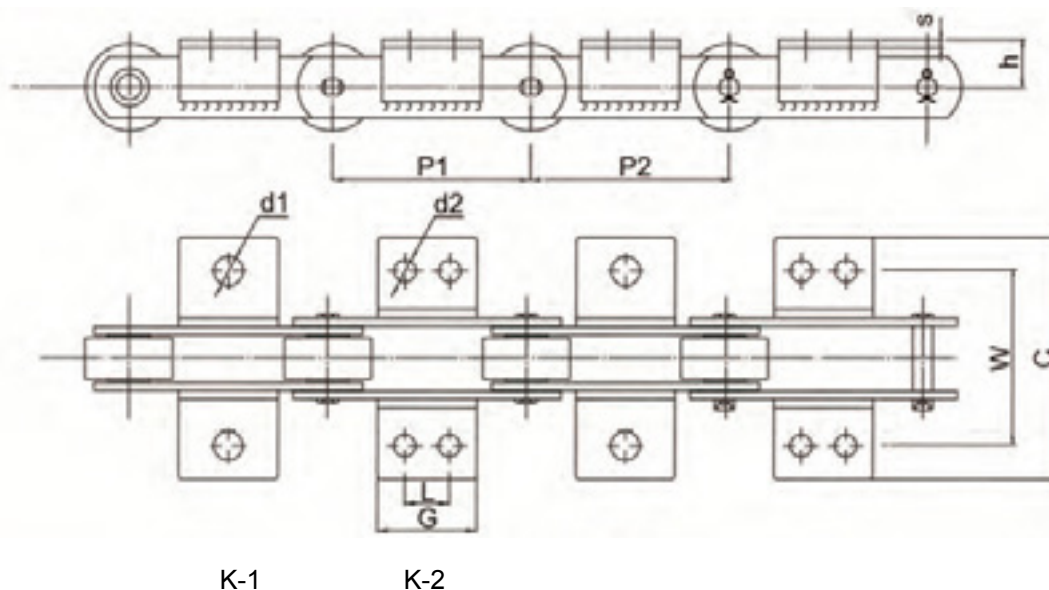

Breaking Load lbf kN	Attachment Face Height h mm	Transverse Pitch W mm	Width Over Attachment Inner/Outer C mm	Attachment Thickness S mm	Attachment Type Inner/Outer	Minimum Pitch		Centre Hole Diameter			Platform Length G mm	Mass kg mm
						Outer Plate P1 mm	Inner Plate P2 mm	d1 mm	d2 mm	L mm		
6000 / 7500	19.0	76.2	102 / 118	4.0	K1	50.8	63.5	10.6	—	—	19.0	0.028
						63.5	76.2	10.6	—	—	28.0	0.054
						76.2	76.2	9.2	7.4	25.4	44.5	0.018
					K2	88.9	101.6	10.6	—	—	56.0	0.104
						88.9	101.6	—	9.2	31.8	56.0	0.104
12000 / 15000	31.8	88.9	125 / 136	5.0	K1	76.2	88.9	13.7	—	—	35.0	0.119
						88.9	101.6	13.7	—	—	56.0	0.193
					K2	88.9	101.6	—	10.5	31.8	56.0	0.193
						114.3	152.4	—	10.5	57.2	84.0	0.289
						152.4	177.8	—	10.5	88.9	127.0	0.443
24000 / 15000	38.0	108.0	145 / 159	6.0	K1	127.0	127.0	15.3	—	—	56.0	0.299
						127.0	127.0	—	12.2	31.8	56.0	0.299
					K2	152.4	152.4	—	12.2	57.2	84.0	0.449
						177.8	177.8	—	12.2	69.9	108.0	0.581
						203.2	203.2	—	12.2	88.9	127.0	0.685
						228.6	228.6	—	12.2	133.4	168.0	0.907
24000 / 30000 / 60000	51.0	146.0	182 / 200	8.0	K1	152.4	152.4	16.9	—	—	70.0	0.581
						152.4	152.4	—	13.7	38.1	70.0	0.581
					K2	203.2	203.2	—	13.7	76.2	112.0	0.930
						228.6	228.6	—	13.7	88.9	152.0	1.27
						304.8	304.8	—	13.7	165.1	229.0	1.905

# BS Conveyor Chain Attachments

## Welded F1

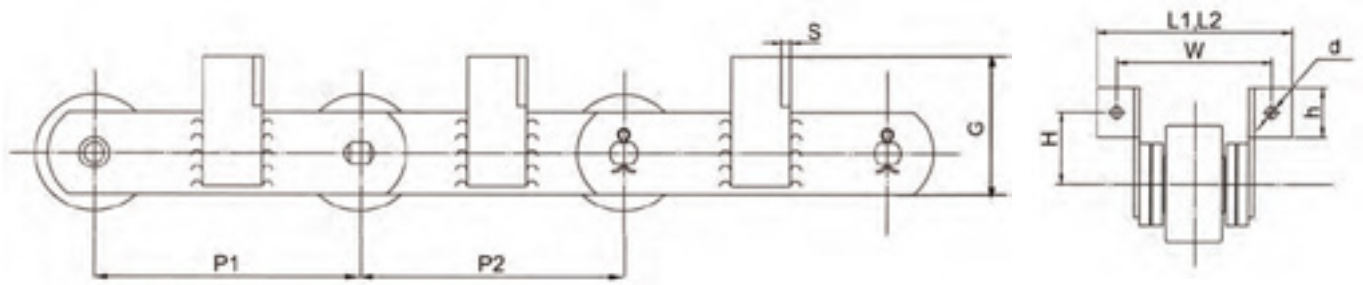

Breaking Load bf kN	Minimum Pitch		Transverse Pitch W mm	Attachment Hole Size d mm	Width Over Attachment		Attachment Thickness S mm	Attachment Face Height h mm	Total Height of Attachment G mm	Attachment Hole Distance From Chain Centreline H mm	Mass kg
	Inner Plate P1 mm	Outer Plate P2 mm			Outer Plate L1 mm	Inner Plate L2 mm					
3000	50.8	38.1	44.5	7.4	74.0	70.0	3.0	19.0	44.5	26.0	0.054
6000 / 7500	69.9	57.2	76.2	9.2	118.0	108.0	4.0	25.4	56.0	32.4	0.082
12000 / 15000	101.6	82.6	88.9	10.5	136.0	125.0	5.0	31.8	84.0	51.4	0.163
24000 / 30000	139.7	114.3	108.0	12.2	159.0	145.0	6.0	44.5	108.0	63.5	0.435
36000 / 45000	165.1	133.4	146.0	13.7	200.0	182.0	8.0	63.5	152.0	88.9	0.954
60000	165.1	133.4	146.0	13.7	200.0	182.0	8.0	63.5	152.0	88.9	0.950
90000	190.5	152.4	171.5	19.5	252.0	229.0	10.0	63.5	152.0	88.9	1.530

## Welded F2

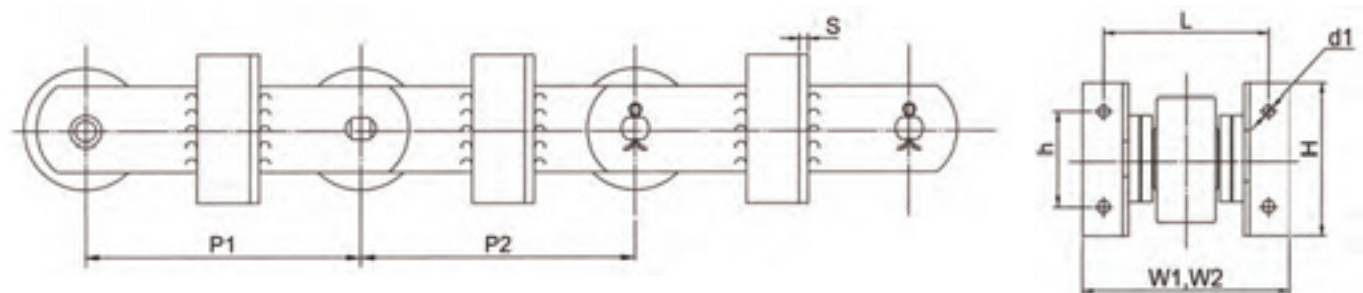

Breaking Load bf kN	Minimum Pitch		Transverse Pitch L mm	Attachment Hole Size d1 mm	Width Over Attachment		Attachment Thickness S mm	Attachment Face Height H mm	Pitch of Attachment Holes h mm	Mass kg
	Inner Plate P1 mm	Outer Plate P2 mm			Outer Plate W1 mm	Inner Plate W2 mm				
3000	50.8	38.1	44.5	7.4	74.0	70.0	3.0	44.5	25.4	0.068
6000 / 7500	69.9	57.2	76.2	9.2	118.0	108.0	4.0	56.0	31.8	0.104
12000 / 15000	101.6	82.6	88.9	10.5	136.0	125.0	5.0	84.0	57.2	0.231
24000 / 30000	139.7	114.3	108.0	12.2	159.0	145.0	6.0	108.0	69.9	0.580
36000 / 45000	165.1	133.4	146.0	13.7	200.0	182.0	8.0	152.0	88.9	1.270
60000	165.1	133.4	146.0	13.7	200.0	182.0	8.0	152.0	88.9	1.270
90000	190.5	152.4	171.5	19.5	252.0	229.0	10.0	152.0	88.9	1.810



# BS Conveyor Chain Attachments

## L Attachment (scraper Chain)

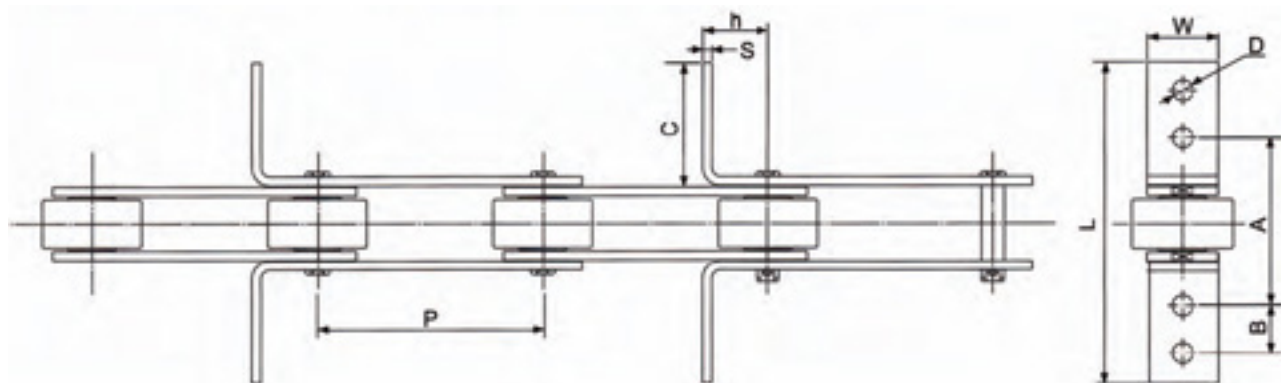

Breaking Load bf kN	Type	Transverse Pitch A mm	Pitch of Attachment Holes B mm	Attachment Face Length C mm	Width Over Attachment Outer L mm	Attachment Hole Diameter D mm	Height of Attachment W mm	Attachment Thickness S mm	Distance of Pitch Point to Attachment Face h mm	Box Width mm	Mass kg
3000	L0	—	—	28.7	74.2	—	18.0	1.8	16.0	76.2	0.007
	L0	—	—	41.4	99.6	—	18.0	1.8	16.0	101.6	0.010
	L0	—	—	54.1	125.0	—	18.0	1.8	16.0	127.0	0.013
	L0	—	—	66.8	150.4	—	18.0	1.8	16.0	152.4	0.016
	L0	41.4	—	25.4	67.6	7.4	18.0	1.8	16.0	—	0.954
	L0	41.4	19.0	41.4	100.0	7.4	18.0	1.8	16.0	—	0.950
6000/7500	L0	—	—	48.3	123.5	—	25.4	3.8	19.0	127.0	0.041
	L0	—	—	61.0	148.9	—	25.4	3.8	19.0	152.4	0.051
	L0	—	—	86.4	199.7	—	25.4	3.8	19.0	203.2	0.071
	L0	—	—	111.8	250.5	—	25.4	3.8	19.0	254.0	0.091
	L0	—	—	137.2	301.3	—	25.4	3.8	19.0	304.8	0.000
	L1	58.5	—	31.8	107.0	9.2	25.4	3.8	19.0	—	0.025
	L2	58.5	21.6	48.3	123.0	9.2	25.4	3.8	19.0	—	0.041
12000/15000	L0	—	—	44.5	122.0	—	38.1	3.8	25.4	127.0	0.058
	L0	—	—	57.2	147.4	—	38.1	3.8	25.4	152.4	0.072
	L0	—	—	82.6	198.2	—	38.1	3.8	25.4	203.2	0.101
	L0	—	—	108.0	249.0	—	38.1	3.8	25.4	254.0	0.130
	L0	—	—	133.4	299.8	—	38.1	3.8	25.4	304.8	0.160
	L1	73.2	—	36.8	106.8	10.5	38.1	3.8	25.4	—	—
	L2	73.2	24.0	57.2	148.6	10.5	38.1	3.8	25.4	—	—
24000/30000	L0	—	—	128.5	300.0	—	51.0	5.1	35.0	320.0	0.267
36000/45000	L0	—	—	135.2	330.0	—	61.0	7.6	42.0	350.0	0.479
60000	L0	—	—	135.2	330.0	—	61.0	7.6	42.0	350.0	0.479

# BS Conveyor Chain Attachments

## Solid Pin Holed Link Plates

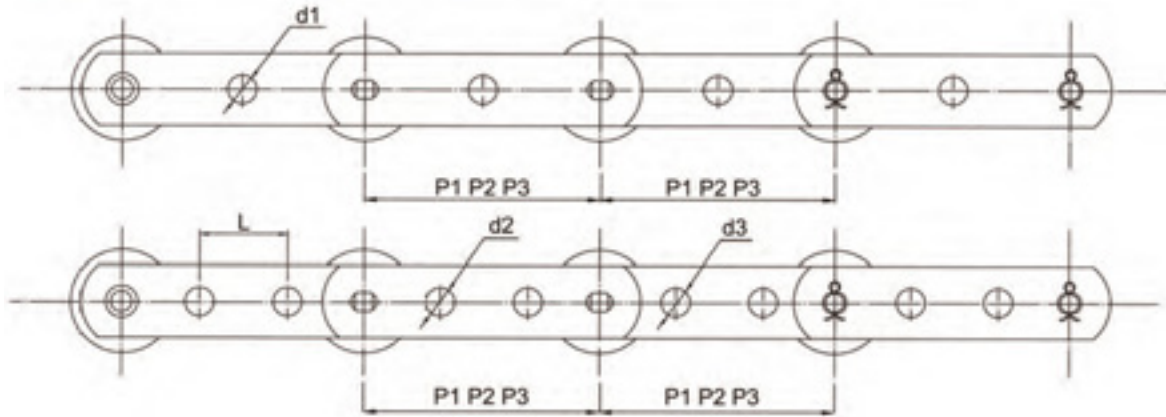

Breaking Load bf kN	One Hole				Two Holes			
	Minimum Pitch Bush Chain P1 mm	Minimum Pitch Small Roller P2 mm	Minimum Pitch Large Roller P3 mm	Hole Diameter d1 mm	Minimum Pitch* mm	Attachment Hole Pitch L mm	Hole Diameter d2 mm	Cone Diameter d3 mm
3000	50.8	50.8	76.2	6.65	—	—	—	—
6000	—	95.3	—	9.9	95.3	38.1	8.3	14.7
7500	—	95.3	—	9.9	127.0	63.5	8.3	14.7
12000 / 15000	—	—	133.35	13.1	101.6	25.4	9.9	17.8
					108.0	34.9	9.9	17.8
					139.7	60.3	9.9	17.8
					177.8	101.6	9.9	17.8
24000 / 30000	—	—	190.5	19.4	127.0	34.9	9.9	17.8
					152.4	60.3	9.9	17.8
					171.5	82.6	9.9	17.8
					190.5	101.6	9.9	17.8
36000 / 45000	241.3	241.3	317.5	22.6	228.6	139.7	9.9	17.8
					152.4	44.5	11.5	20.8
					190.5	190.5	11.5	20.8
					228.6	228.6	11.5	20.8
60000	241.3	241.3	317.5	22.6	304.8	304.8	11.5	20.8
					152.4	152.4	11.5	20.8
					190.5	82.6	11.5	20.8
					222.3	114.3	11.5	20.8
90000	279.4	279.4	330.2	29.0	298.5	190.5	11.5	20.8
					177.8	50.8	16.7	30.5
					228.6	108.0	16.7	30.5
					304.8	184.2	16.7	30.5

Extended Bearing Spigot Pins

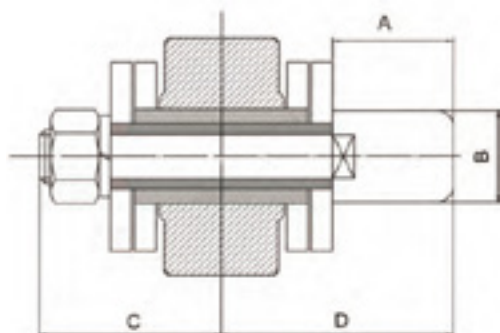

Type A

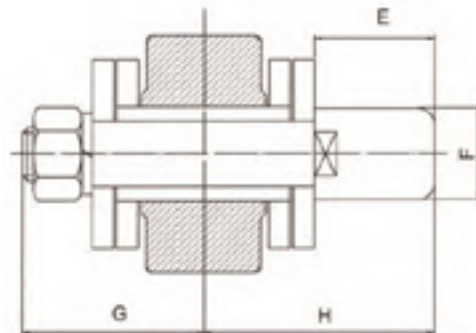

Type B

Breaking Load lbf	A mm	B mm	C mm	D mm	E mm	F mm	G mm	H mm	Mass kg
3000	—	—	—	—	25.4	11.0	17.0	35.0	0.036
6000	38.1	16.0	31.0	57.0	38.1	16.0	29.2	56.0	0.012
7500	—	—	—	—	38.1	16.0	29.2	56.0	0.012
12000	44.5	19.0	36.3	66.3	44.5	19.0	34.3	64.8	0.200
15000	—	—	—	—	44.5	19.0	34.3	64.8	0.200
24000	57.2	28.6	48.0	85.3	57.2	28.6	45.7	83.8	0.560
30000	—	—	—	—	57.2	28.6	45.7	83.8	0.560
36000	70.0	31.8	61.0	109.0	70.0	31.8	58.5	107.0	0.900
45000	—	—	—	—	70.0	38.1	58.5	107.0	0.900
60000	—	—	—	—	70.0	38.1	58.5	107.0	0.900
90000	—	—	—	—	70.0	38.0	71.0	113.0	1.490

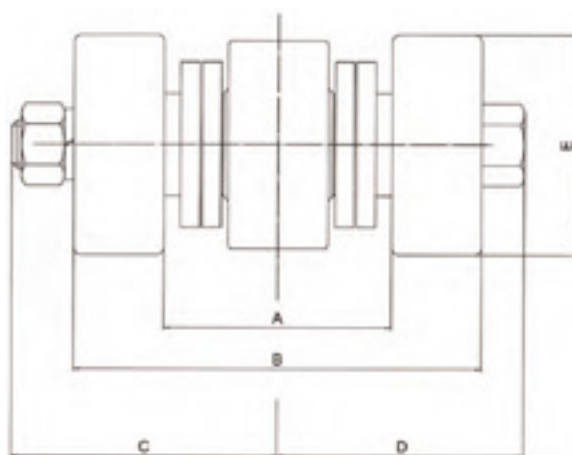

Breaking Load lbf	A mm	B mm	C mm	D mm	E mm	Mass kg	Roller Lead Per Pitch Point kg
6000	44.45	75.0	55.6	46.5	33.3	0.26	165
12000	50.80	88.9	68.5	57.0	50.8	0.73	290
24000	60.00	118.0	86.6	75.7	69.9	1.94	545
36000	94.00	171.5	113.5	106.0	92.1	4.74	725

## Solid Pin

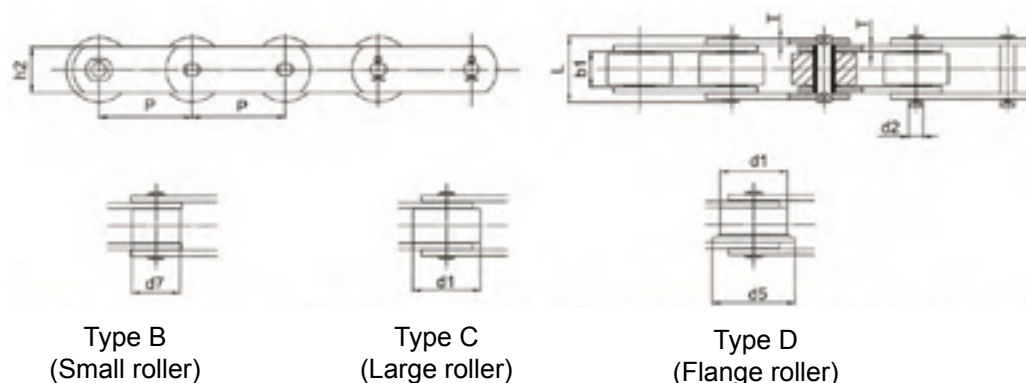

Chain No.	Q kN	Pitch P											Roller Diameter			Pin Diameter d2 max	Pin Length L max	Width Between Inner Plates b1 min	Plate Depth h2 max	Plate
		50	63	80	100	125	160	200	250	315	400	500	d7	d1	d5					
M20	20		√	√	√	√	√						12.5	25	32	6.0	35	16	19	3.0
M28	28		√	√	√	√	√	√					15	30	36	7.0	40	18	21	3.5
M40	40		√	√	√	√	√	√					18	36	42	8.5	45	20	26	4.0
M56	56			√	√	√	√	√	√				21	42	50	10.0	52	24	31	4.5
M80	80			√	√	√	√	√	√	√			25	50	60	12.0	62	28	36	5.0
M112	112				√	√	√	√	√	√	√		30	60	70	15.0	73	32	41	6.0
M160	160					√	√	√	√	√	√		36	70	85	18.0	85	37	51	7.0
M224	224						√	√	√	√	√		42	85	100	21.0	98	43	62	8.0
M315	315							√	√	√	√		50	100	120	25.5	112	48	72	10.0
M450	450								√	√	√		60	120	140	30.0	135	56	82	12.5
M630	630									√	√		70	140	170	36.0	154	66	103	14.5

# M Series Conveyor Chain

## Hollow Pin

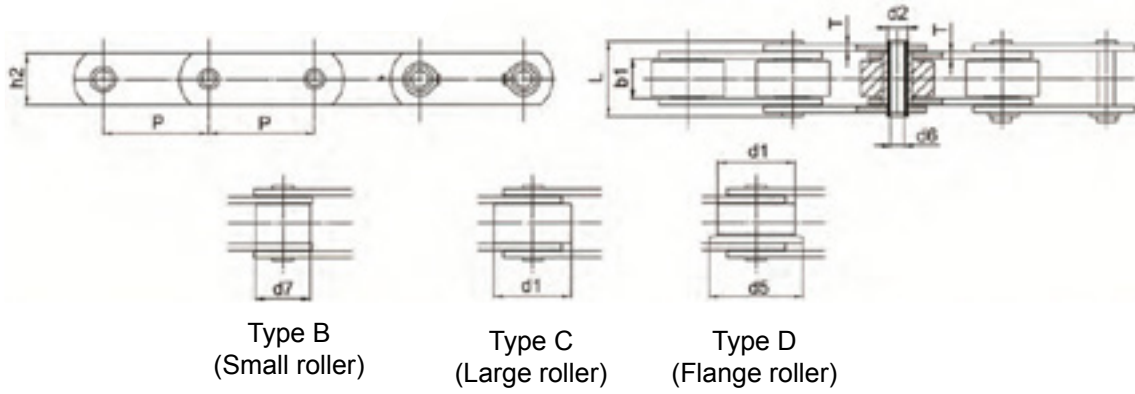

Chain No.	Q kN	Pitch P											Roller Diameter			Pin Diameter		Pin Length L max	Width Between Inner Plates b1 min	Plate Depth h2 max	Plate
		50	63	80	100	125	160	200	250	315	400	500	d7	d1	d5	d2 max	d6 max				
MC28	28	√	√	√	√	√	√						25	36	42	13	8.2	42	20	26	3.5
MC56	56		√	√	√	√	√	√					30	50	60	15.5	10.2	48	24	36	4.5
MC112	112			√	√	√	√	√	√	√			42	70	85	22	14.0	67	32	51	6.0
MC224	224							√	√	√	√	√	60	100	120	31	20.3	90	43	72	8.0

## Attachments

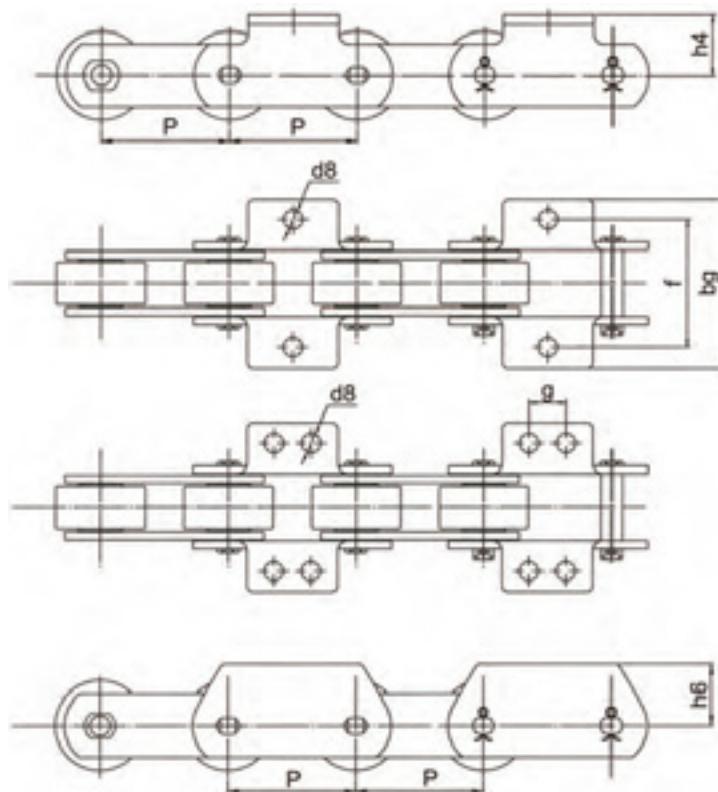

Chain No.	K attachment				P mm	g	P mm	g	P mm	g	H Type h6
	d8	h4	f	b9 max							
M20	6.6	16	54	84	63	20	80	35	100	50	16
M28	9	20	64	100	80	25	100	40	125	65	20
M40	9	25	70	112	80	20	100	40	125	65	22.5
M56	11	30	88	140	100	25	125	50	160	85	30
M80	11	35	96	160	125	50	160	85	200	125	32.5
M112	14	40	110	184	125	35	160	65	200	100	40
M160	14	45	124	200	160	50	200	85	250	145	45
M224	18	55	140	228	200	65	250	125	315	190	60
M315	18	65	160	250	200	50	250	100	315	155	65
M450	18	75	180	280	250	85	315	155	400	240	80
M630	24	90	230	380	315	100	400	190	500	300	90
M900	30	110	280	480	315	65	400	155	500	240	120
MC28	9	25	70	112	80	20	100	40	125	65	22.5
MC56	11	35	88	152	125	50	160	85	200	125	32.5
MC112	14	45	110	192	160	50	200	85	250	145	45
MC224	18	65	140	220	200	50	250	100	315	155	65

**Solid Pin**

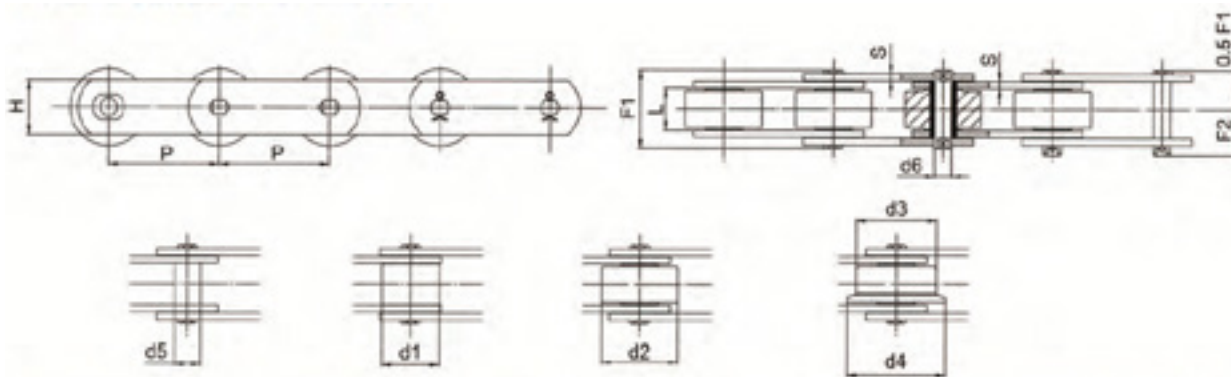

**Type A**  
(Bush type)

**Type B**  
(Small roller)

**Type C**  
(Large roller)

**Type D**  
(Flange roller)

Chain No.	Pitch P										Width Between Inner Plates L min	Roller Diameter					Pin Diameter d6 max	Plate Depth H max	Plate Thickness S max	Pin Length		Average Tensile Strength kN
	50	63	80	100	125	160	200	250	315	400		d1	d2	d3	d4	d5				F1	F2	
FV40	√	√	√	√	√	√					18	20	32	40	50	15	10	25	3	35	21	47
FV63		√	√	√	√	√	√				22	26	40	50	63	18	12	30	4	40	26	75
FV90		√	√	√	√	√	√				25	30	48	63	78	20	14	35	5	45	30	115
FV112			√	√	√	√	√	√			30	32	55	72	90	22	16	40	6	52	35	170
FV140			√	√	√	√	√	√	√		35	36	60	80	100	26	18	45	6	62	38	180
FV180				√	√	√	√	√	√	√	45	42	70	100	125	30	20	50	8	85.3	49	250
FV250					√	√	√	√	√	√	55	50	80	125	155	36	26	60	8	85	55	300
FV315						√	√	√	√	√	65	60	90	140	175	42	30	70	10	98	70	480

**Hollow Pin**

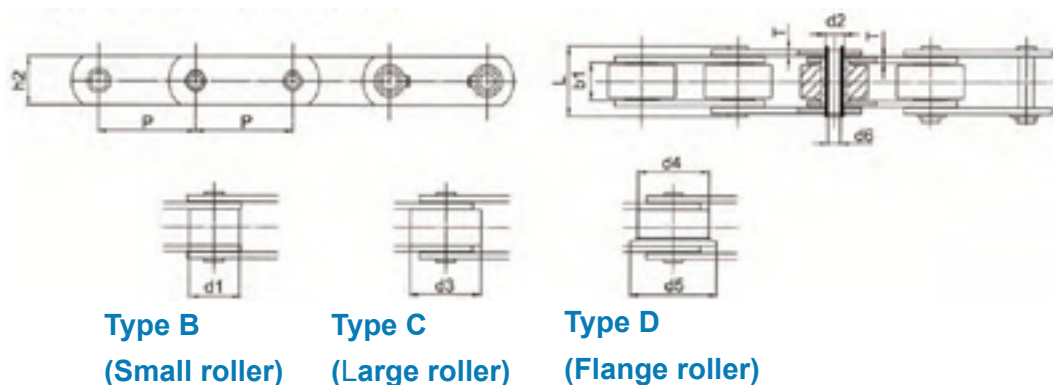

Chain No.	Q kN	Pitch P								Roller Diameter				Pin Diameter		Pin Length L max	Width Between Inner Plates		Plate Depth h2 max	Plate Thickness T max
		63	80	100	125	160	200	250	315	400	d1	d2	d3	d4	d2 max		d6 max	b1 min		
FVC63	46	√	√	√	√	√					26	40	50	63	12	8	45	22	30	4
FVC90	73	√	√	√	√	√	√	√			30	48	63	78	14	10	53	25	35	5
FVC112	90			√	√	√	√	√			32	55	72	90	16	11	62	30	40	6
FVC140	110			√	√	√	√	√			36	60	80	100	18	12	67	35	45	6
FVC180	145				√	√	√	√	√		42	70	100	125	20	14	86	45	50	8
FVC250	215					√	√	√	√	√	50	80	125	155	26	18	97	55	60	8
FVC315	295					√	√	√	√	√	60	90	140	175	30	20	113	65	70	10



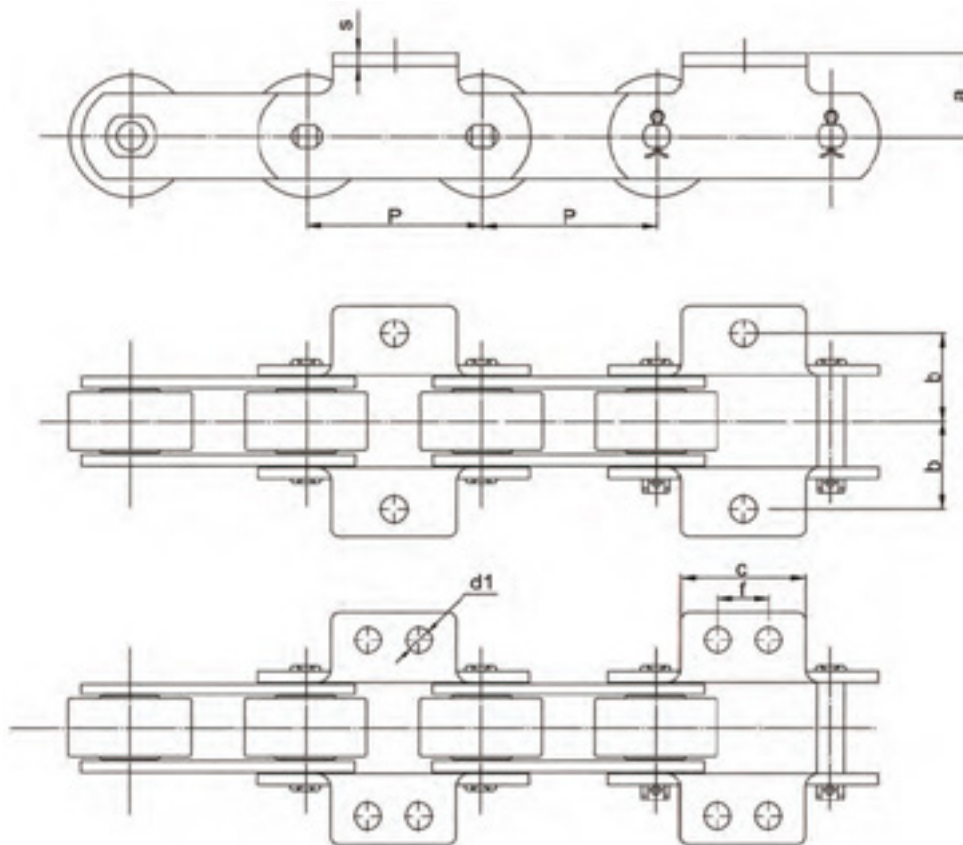

Chain No.	C mm							a mm	b mm	d1 mm	f mm
FV40	31	45	50	60	—	—	—	20	25	6.5	25 / 30
FV63	40	45	50	60	70	—	—	30	34	8.4	25 / 30 / 40 / 50
FV90	30	45	50	60	70	80	85	35	40	8.4	25 / 30 / 40 / 50 / 60 / 65
FV112	50	65	75	90	105	—	—	40	50	11	30 / 40 / 50 / 65 / 80
FV140	55	65	75	90	105	—	—	45	50	11	30 / 40 / 50 / 65 / 80
FV180	63	80	95	110	130	—	—	45	64	13	35 / 50 / 65 / 80 / 100
FV250	80	95	110	130	—	—	—	55	69	14	50 / 65 / 80 / 100
FV315	50	95	110	130	—	—	—	60	85	14	65 / 80 / 100

# SC/HC Series Conveyor Chain

## SC Series Solid Pin

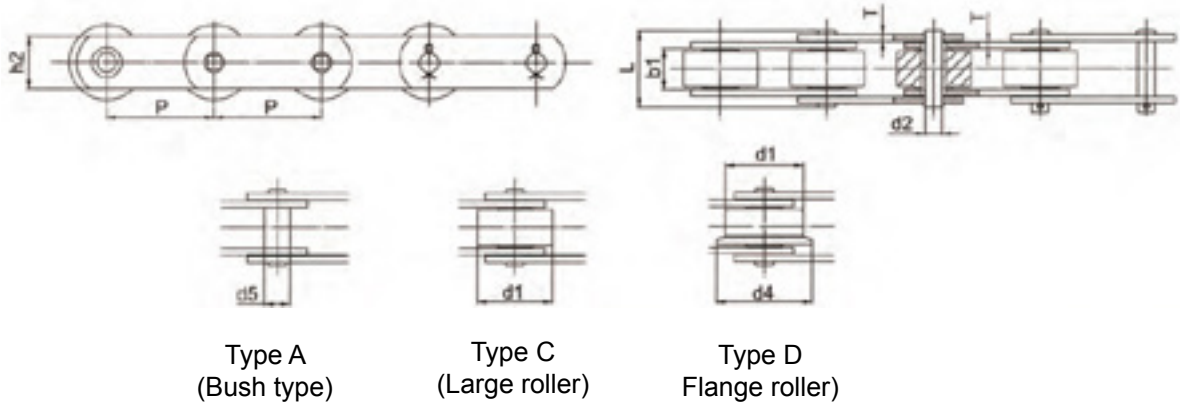

Chain No.	Q lbf	Pitch P												Roller Diameter			Pin Diameter d2 max	Pin Length L max	Width Between Inner Plates b min	Plate Depth h2 max	Plate Thickness T max
		2	2.5	3	3.5	4	5	6	7	8	9	10	12	d5	d1	d4					
SC75	7500	✓	✓	✓	✓	✓	✓	✓						17	31.75	40	14	37	15	25	4
SC150	15000			✓	✓	✓	✓	✓	✓	✓				23	47.5	60	19	45	19	40	5
SC300	30000					✓	✓	✓	✓	✓	✓	✓		33	66.7	82	26.9	58	26	50	7
SC600	60000							✓	✓	✓	✓	✓	✓	38	88.9	114	32	84	38	60	10

## HC Series Hollow Pin

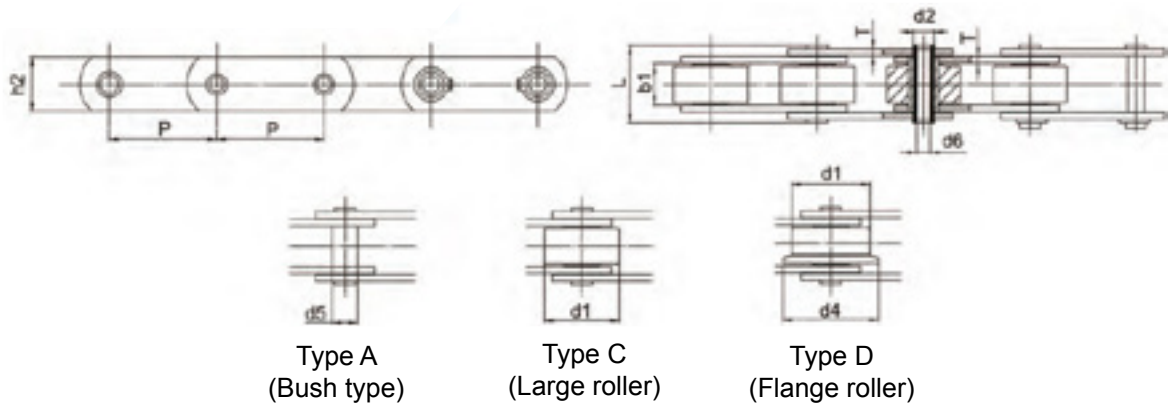

Chain No.	Q lbf	Pitch P												Roller Diameter			Pin Diameter		Pin Length L max	Width Between Inner Plates b min	Plate Depth h2 max	Plate Thickness T max
		1.52	2	2.5	3	3.5	4	5	6	7	8	9	10	12	d5	d1	d4	d2 max				
HC63	4500	✓	✓	✓	✓									11	25.4	—	9	6.5	26	12.7	18	2.5
HC60	6000		✓	✓	✓	✓	✓	✓	✓					17	31.75	40	14	10.2	36.4	15	25	4
HC120	12000				✓	✓	✓	✓	✓	✓	✓			23	47.5	60	19	13.2	45	19	40	5
HC240	24000				✓	✓	✓	✓	✓	✓	✓	✓		33	66.7	82	26.9	20.2	58	26	50	7
HC360	36000					✓	✓	✓	✓	✓	✓	✓	✓	38	88.9	114	32	22.5	83	38	60	10

# SC Series Conveyor Chain Attachments

## Solid Pin

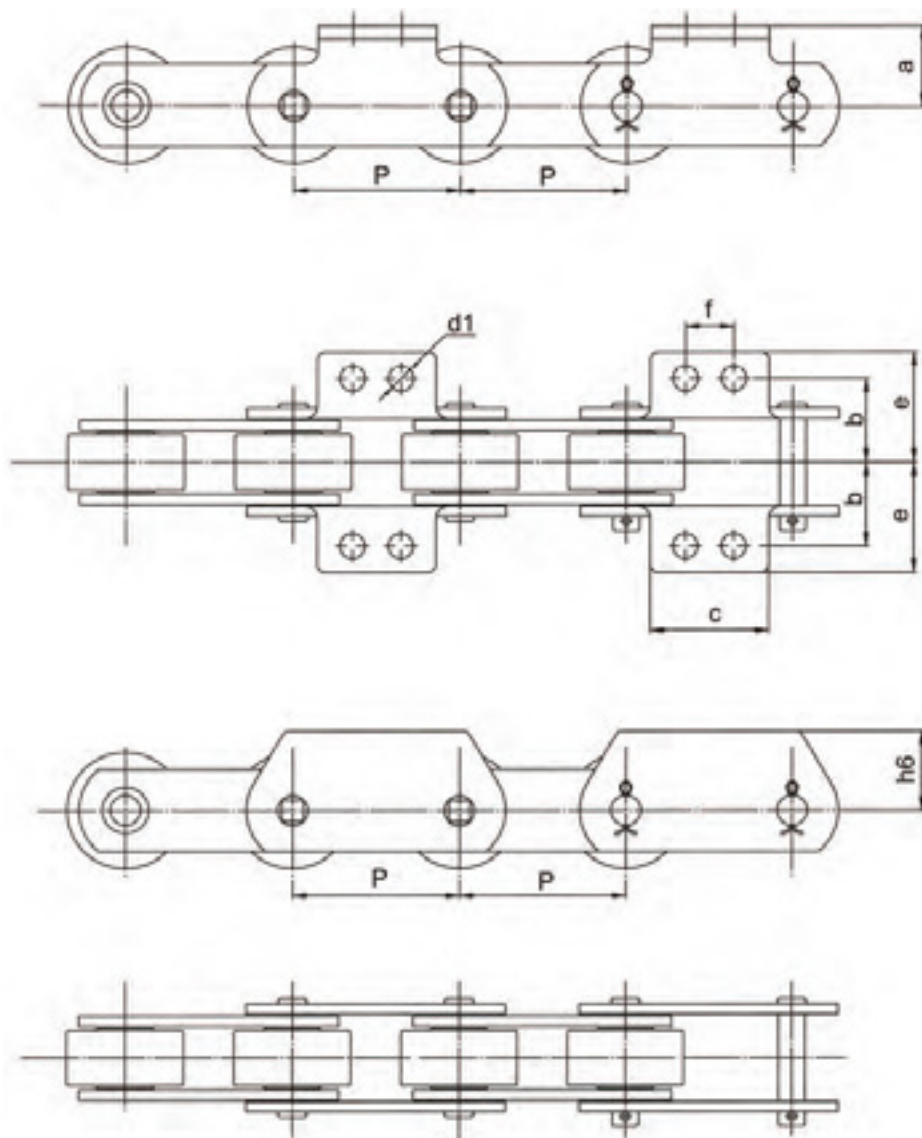

Chain No.	A Type						H Type h6
	a	d1	c	f	b	e	
SC75	19	9.3	43, 45, 50, 64, 84	43, 45, 50, 64, 84	38.1	55, 56, 64.5, 65	27
SC150	32	10.5	30, 64, 84, 114.5, 110	31.8, 57.2, 80	44.45	65	30
SC300	38	12.3	35, 56, 84, 150, 170	31.7, 57.2, 100, 135	54	77	45
SC600	51	14	70, 100, 152.4, 225	38.1, 76.2, 90, 190	73	100	60

**R Roller**

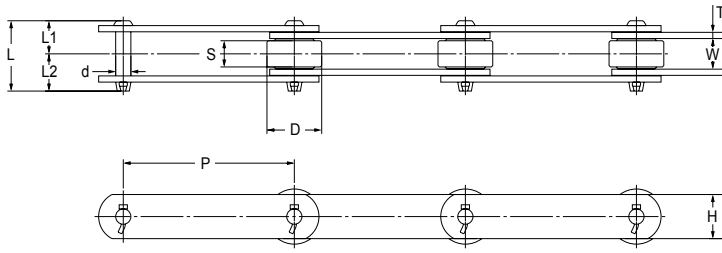

**F Roller**

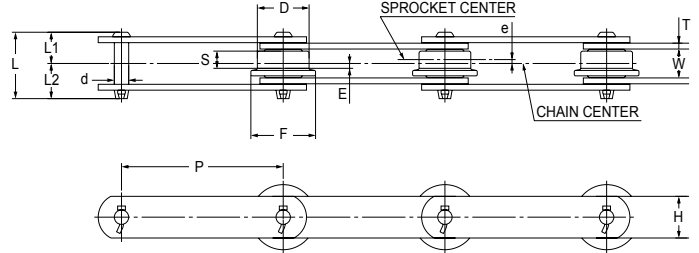

Chain No.	Roller Type	Average Tensile Strength				R Roller		F Roller		
		FM.FE		FMH.FEH		Pitch P	D	S	D	S
		kN	kgf	kN	kgf					
FM.FMH3075	R.F.S	29.41	3,000	60.78	6,000	75	30 (31.8)	15.5	38 (42)	12
FM.FMH3100						100				
FM.FMH3125						125				
FM.FMH3150						150				
FM.FMH5075	R.F.S	68.64	7,000	138.24	14,100	75	40	19	50	14
FM.FMH5100						100				
FM.FMH5125						125				
FM.FMH5150						150				
FM.FMH7100	R.F.S	84.31	8,600	171.57	17,500	75	45	21.5	60	16
FM.FMH7125						100				
FM.FMH7150						125				
FM.FMH7175						150				
FM.FMH7200						200				
FM.FMH 10100	R.F.S.M	112.75	11,500	225.49	23,000	75	50	26.5	65	20
FM.FMH 10125						100				
FM.FMH 10150						125				
FM.FMH 10200						150				
FM.FMH 12200	R.F.S.M	186.32	19,000	277.45	28,300	250	65	32	85	24
FM.FMH7200						200				
FM.FMH 17200						200				
FM.FMH 17250	R.F.S.M	245.10	25,000	392.16	40,000	250	80	45.8	105	34
FM.FMH 17300						300				

## R Roller

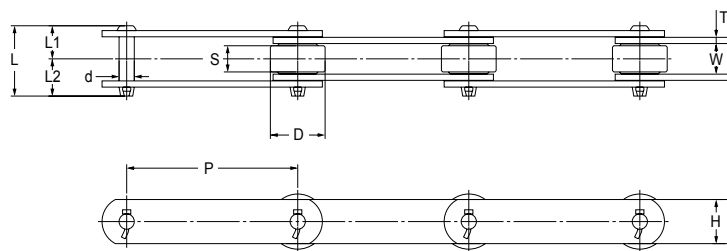

## F Roller

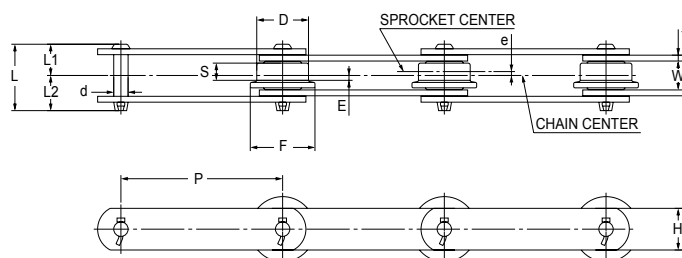

Chain No.	Roller Type	Average Tensile Strength				Pitch P	R Roller		F Roller	
		FM.FE		FMH.FEH			D	S	D	S
		kN	kgf	kN	kgf					
FM.FMH 20200	R.F.S	205.88	21,000	411.18	45,000	200	75	40.5	100	30
FM.FMH 20250						250				
FM.FMH 26250						250				
FM.FMH 26300	R.F.S.M	279.41	28,500	529.41	54,000	300	100	50	130	38
FM.FMH 26450						450				
FM.FMH 36250	R.F.S.M	475.49	48,500	686.42	70,000	250	125	56	160	42
FM.FMH 36300						300				
FM.FMH 36450						450				
FM.FMH 36600						600				
FM.FMH 52450	R.F.S	539.22	55,000	1078.43	110,000	450	140	65	180	49
FM.FMH 52600						600				
FM.FEH7100	R.F.S	539.22	5,500	98.04	10,000	101.60	38.1	18.7	50	13
FM.FEH5400	R.F.S.M	53.92	8,500	132.35	13,500	101.60	44.45	23.5	60	21.5
FM.FEH5600						152.40			65	20
FE.FEH9400	R.F.S.M	83.33	14,000	274.57	28,000	101.60	44.45	27.5	60	19.5
FM.FEH12600	R.F.S.M	186.32	19,000	274.57	28,000	152.40	57.2	31.5	75	25
FM.FEH17600	R.F.S.M	205.88	21,000	392.16	40,000	152.40	69.9	31.5	90	23.5
FE.FEH5261	S	83.33	8,500	132.35	13,500	66.27	—	—	—	—
FE.FEH7400	S	98.04	10,000	166.71	17,000	101.60	—	—	—	—
FE.FEH9307	S	117.65	12,000	225.49	23,000	78.11	—	—	—	—

## S (M)

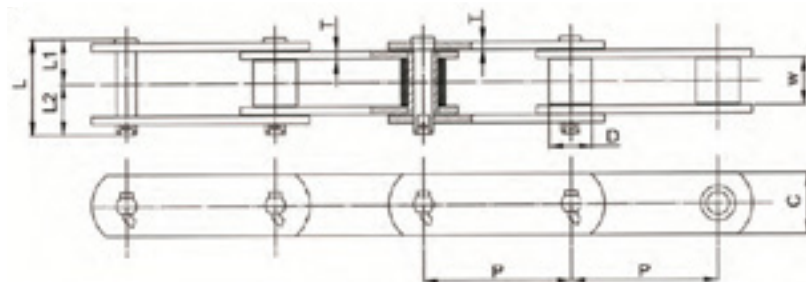

F Roller			S Roller	M Roller	Inner Width	Side Plate		Pin				Side Plate			
D	F	S	D	D	W	C	T	d	L	L1	L2	R	F	S	M
30 (31.8)	38 (42)	12	19.05 (15.9)	—	18 (16.1)	22	3.2	7.49	38 (36.4)	18 (17.1)	20 (19.3)	2.5	2.7	2.0	—
												2.2	2.3	1.8	—
												2.0	2.1	1.6	—
												1.9	2.0	1.4	—
40	50	14	22.2	—	22.5	32	4.5	11.11	51	25	27	5.6	5.8	5.4	—
												5.0	5.2	4.8	—
												4.5	4.7	4.3	—
												4.1	4.3	3.9	—
45	60	16	27	—	25	32	60	12.7	61.5	29	32.5	6.8	7.2	6.0	—
												6.1	6.5	5.5	—
												5.5	5.8	5.0	—
												5.0	5.4	4.5	—
50	65	20	30	31.8	30	38	6.3 *(6.0)	14.29	68	32	36	10.0	10.2	9.4	9.8
												8.7	8.9	8.1	8.5
												7.5	7.7	6.9	7.2
												6.5	6.7	5.9	6.2
65	85	24	34.93	38.8	36.5	45	7.9 *(8.0)	15.88	85.5	39.5	46	11.6	12.2	8.4	8.7
												10.4	10.9	7.8	8.0
80	105	34	40.08	44.5	50.8	50.8	9.5 *(9.0)	19.05	110.5	51	59.5	19.7	20.7	12.0	13.0
												17.2	18.2	11.1	12.2
												15.8	16.6	10.5	11.5

## S(M)

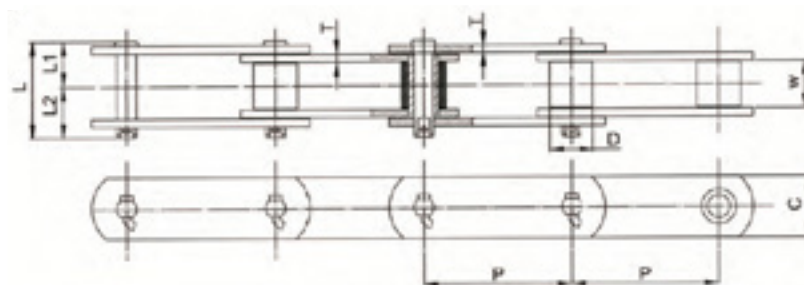

F Roller			S Roller	M Roller	Inner Width	Side Plate		Pin				Side Plate			
D	F	S	D	D	W	C	T	d	L	L1	L2	R	F	S	M
75	100	30	40	—	45	50.8	9.5 *(9.0)	20.64	103	47.5	55.5	16.8	17.8	—	—
												14.8	15.7	—	—
100	130	38	44.45	50.8	56.6	63.5	9.5 *(9.0)	22.23	118	54	62	26.2	27.8	14.7	16.0
												23.4	24.7	13.8	15.0
												18.7	19.6	12.4	14.5
125	160	42	50.8	57.2	66	76.2	12.7 *(12.0)	25.4	141	65.5	75.5	45.7	47.6	24.0	25.0
												40.4	42.0	22.9	24.0
												31.8	33.3	20.2	21.0
												27.8	29.0	19.0	20.0
140	180	49	57.1	—	76	90	16.0	32.0	169	79	90	45.8	48.0	26.2	—
												39.8	41.8	24.2	—
38.1	50	13	20.1	—	22.2	25.4	4.8, *(4.5)	9.53	51	24	27	4.3	4.7	3.0	—
44.45	60	21.5	22.2	25.4	27	28.6	6.3, *(6.0)	11.11	63	30	33	6.7	6.9	4.6	4.9
50.8	65	20	25.8		30	38		11.11	66	31.5	34.5	7.8	8.1	5.0	
44.45	60	19.5	31.75	34.9	31	38	7.9, *(8.0)	15.88	78.5	37	41.5	10.4	10.7	8.7	9.1
57.2	75	25	34.93	38.1	36.5	45	7.9, *(8.0)	15.88	86	40	46	12.1	12.4	9.3	9.6
69.9	90	23.5	40.08	44.4	36.5	50.8	9.5 *(9.0)	19.05	94	43.5	50.5	17.1	17.6	12.6	13.0
—	—	—	22.2	—	27	28.6	6.3, *(6.0)	11.11	63	30	33	—	—	5.6	—
—	—	—	25	—	28.6	38	6.3, *(6.0)	12.7	66	31	35	—	—	6.5	—
—	—	—	31.75	—	36.5	38	7.9, *(8.0)	14.29	81.5	39	42.5	—	—	10.3	—

**A2**

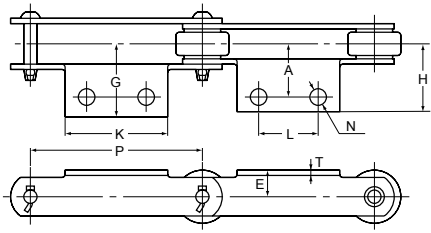

**SA2**

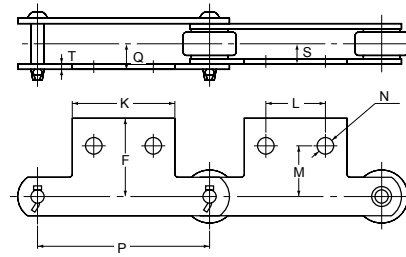

**K2**

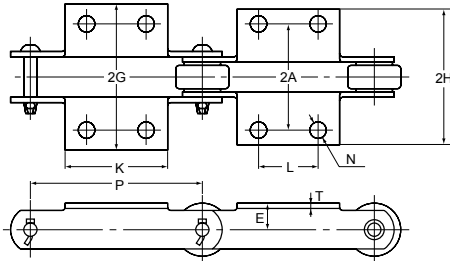

**SK2**

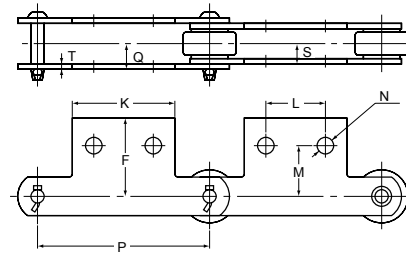

Chain No.	Pitch P	Side Plate		A-2, K-2 Attachment					SA-2 · SK-2 Attachment					Weight Per Attachment	
		T	K	N	L	A	E	G	H	M	F	S	Q	A-2(kg)	K-2(kg)
FM 3075-R · F · S	75	3.2	60(55)	10	35(30)	30	15 (20)	46	42.4	30	42	12.2	15.8	0.05	0.10
FM3100-R · F · S	100		65		40									0.06	0.12
FM3125-R · F · S	125		75		50									0.06	0.12
FM3150-R · F · S	150		85		60									0.07	0.14
FM5075-R · F · S	75	4.5	58	10	35	35	22	56.5	51.6	40	54	15.6	20.5	0.07	0.14
FM5100-R · F · S	100		65		40									0.08	0.16
FM5125-R · F · S	125		75		50									0.09	0.18
FM5150-R · F · S	150		85		60									0.10	0.20
FM7100-R · F · S	100	6.0	70	12	40	40	25	63	56.6	45	58	18.5	24.9	0.20	0.40
FM7125-R · F · S	125		80		50									0.22	0.44
FM7125-R · F · S	150		90		60									0.25	0.50
FM7175-R · F · S	175		100		70									0.28	0.56
FM10100-R · F · S · M	100	6.3	70	12	40	50	28	74	67.2	50	69	21.3	28.1	0.18	0.36
FM10125-R · F · S · M	125		80		50									0.23	0.46
FM10150-R · F · S · M	150		90		60									0.28	0.56
FM10200-R · F · S · M	200		120		80									0.37	0.74
FM12200-R · F · S · M	200	7.9	120	15	80	60	38	85	78.5	60	82.5	26.2	34.7	0.42	0.84
FM12250-R · F · S · M	250		170		125									0.58	1.16
FM17200-R · F · S · M	200	9.5	120	15	80	75	45	108	97.7	70	100.6	34.9	45.2	0.80	1.60
FM17250-R · F · S · M	250		170		125									1.11	2.22
FM26250-R · F · S · M	250	9.5	170	15	125	80	55	111.2	101.2	80	111.3	37.8	48.1	1.17	2.34
FE3400-R · F · S	101.60	4.8	70	11	40	40	22	59	53.9	40	55.3	15.9	21	0.15	0.30
FE5400-R · F · S · M	101.60	6.3	70	11	40	50	28	74	67.3	50	70.7	19.8	26.5	0.20	0.40
FE5600-R · F · S · M	152.40	6.3	70	11	60	50	32	72	65.2	50	71	21.3	28.1	0.25	0.50
FE9400-R · F · S · M	101.60	7.9	80	15	40	55	35	84	75.6	60	81	23.4	31.8	0.30	0.60
FE12600-R · F · S · M	152.40	7.9	100	15	60	60	38	85	76.5	60	82.5	26.2	34.7	0.40	0.80
FE17600-R · F · S · M	152.40	9.5	100	15	60	65	45	94.5	94.6	70	94.6	27.8	38	0.55	1.10



G-2

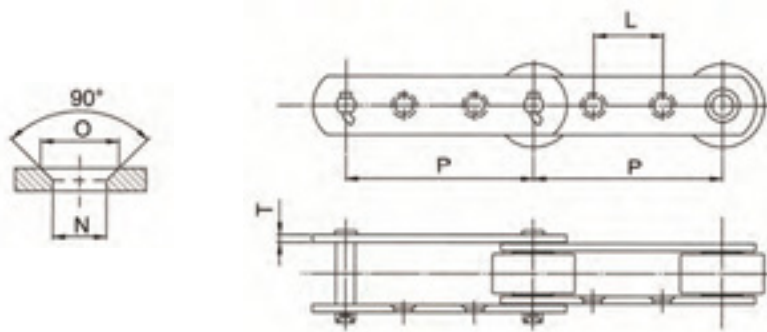

Chain No.	Pitch P	Side Plate T	G-2 Attachment			Max Length of Bolt	
			N	O	L	Pin Link	Roller Link
FM3075-R · S	75	3.2	8	13	30	27	20
FM 3100-R · F · S	100				40		
FM 5100-R · S	100	4.5	9.5	17	40	35	25
FM5150-R · F · S	150				60		
FM 10100-S	100	6.3	11	22	30	49	35
FM 10150-R · F · S · M	150				60		
FM 12200-R · F · S · M	200	7.9	15	27	80	63	45
FM 12250-R · F · S · M	250				125		
FM 17200-R · F · S · M	200	9.5	15	27	80	80	60
FM 17250-R · F · S · M	250				110		
FM 17300-R · F · S · M	300				150		
FM 26300-R · F · S · M	300	9.5	15	27	140	86	64
FM 26450-R · F · S · M	450				220		
FM36450-R · F · S · M	450	12.7	19	32	220	105	78
FM 36600-R · F · S · M	600				300		
FM 52450-R · F · S	450	16.0	22	38	220	124	89
FM 52600-R · F · S	600				300		
FE5600-R · F · S	152.40	6.3	11	22	60	48	34
FE12600-R · F · S	152.40	9.5	15	27	50	62	44

# FM Series Attachments

G-4

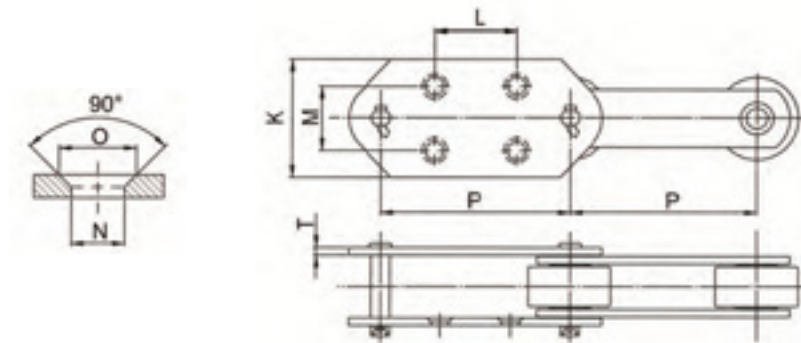

Chain No.	Pitch P	Side Plate T	G-4 Attachment					Weight Per Pc	Weight at Every 2nd Link (kg/m)			
			N	O	L	M	K		R Roller	F Roller	S Roller	Bush Type
FM 5150-R · F · S	150	4.5	9.5	17	75	70	100	0.43	5.5	5.7	5.3	4.4
FM 10150-R · F · S · M	150	6.3	11	22	75	70	110	0.61	9.5	9.7	8.9	7.7
FM 12200-R · F · S · M	200	7.9	15	27	100	80	130	0.94	14.0	14.6	10.8	—
FM 12250-R · F · S · M	250				140	100	150	1.45	13.3	13.8	10.7	—
FM 17200-R · F · S · M	200	9.5	15	27	100	80	130	1.12	22.5	23.5	14.8	—
FM 17250-R · F · S · M	250				140	100	150	1.69	20.6	21.6	14.5	—
FM 17300-R · F · S · M	300				180	120	170	2.39	19.8	20.6	14.5	—
FM 26300-R · F · S · M	300	9.5	15	27	180	120	170	2.24	27.1	28.4	17.5	—
FM26450-R · F · S · M	450				250	140	190	3.98	23.1	24.0	16.8	—
FM 36250-S	250	12.7	15	27	140	100	150	1.98	—	—	27.9	—
FM 36300-S	300				180	100	150	2.38	—	—	26.8	—
FE 5600-R · F · S · M	152.40	6.3	11	22	75	70	110	0.50	9.4	9.7	7.6	—
FE12600-R · F · S · M	152.40	7.9	15	27	75	70	120	0.53	13.8	14.1	11.0	—

# Solid Pin Conveyor Chain

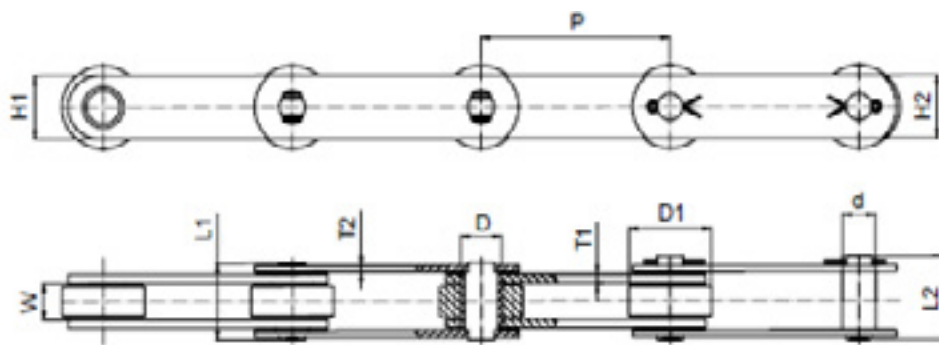

Minimum Breaking Load (lbs)	Pitch P		Roller Width W mm	Roller Diameter d1 mm	Bush Diameter D mm	Solid Pin Diameter d mm	Solid Pin Length L1 (max) mm	Connecting Pin Length L2 (max) mm	Inner Plate		Outer Plate		Average Wt/ ft kg
	inch	metric							H1 mm	T1 mm	H2 mm	T2 mm	
7500	2.0	50.80	15.24	31.75	18.00	14.27	40.6	50.8	25.0	5.0	25.0	5.0	1.3
	3.0	76.20											1.2
	4.0	101.60											1.0
	6.0	152.40											0.9
15000	3.0	76.20	19.05	47.62	23.8	19.05	48.26	57.0	40.0	6.0	40.0	6.0	2.3
	4.0	101.60											2.0
	5.0	127.00											1.8
	6.0	152.40											1.6
	8.0	203.20											1.4
30000	4.0	101.60	25.40	66.67	33.0	27.0	61.98	74.0	50.0	8.0	50.0	6.0	4.3
	5.0	127.00											3.7
	6.0	152.40											3.4
	7.0	177.80											3.1
	8.0	203.20											2.9
	9.0	228.60											2.9
	10.0	254.00											???
	12.0	304.80											2.5
45000	6.0	152.40	38.10	88.90	38.10	31.75	84.13	110.5	65.0	10.0	65.0	8.0	7.1
	8.0	203.20											5.9
	9.0	228.60											5.5
	12.0	304.80											4.6
60000	6.0	152.40	38.10	88.90	38.10	31.75	84.13	110.5	65.0	10.0	65.0	8.0	7.1
	9.0	228.60											5.6
	12.0	304.80											4.6
85000	6.0	152.40	38.10	88.90	38.10	31.75	82.86	118.4	65.0	12.0	65.0	10.00	9.7
	9.0	228.60											8.3
	12.0	304.80											7.1

# Hollow Pin Conveyor Chain

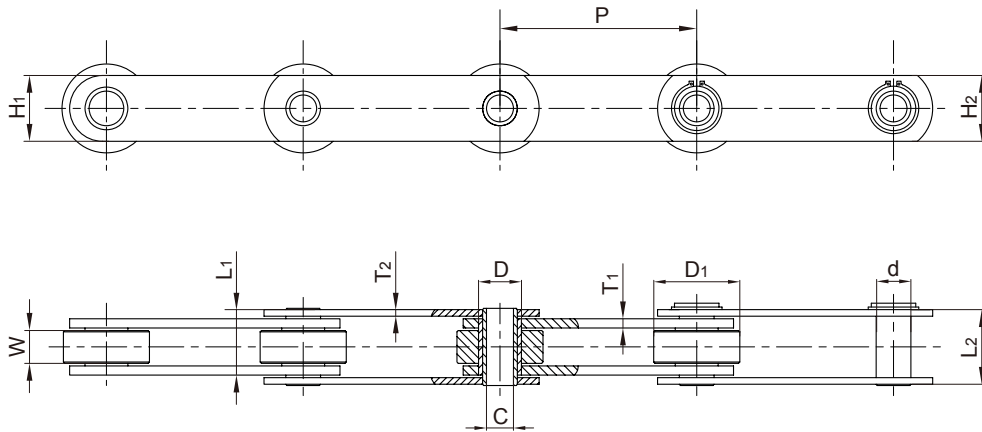

Minimum Breaking Load (lbs)	Pitch P		Roller Width W mm	Roller Diameter D1 mm	Bush Diameter D mm	Hollow Pin Bore Diameter C (min) mm	Hollow Pin Bore Diameter min mm	Hollow Pin Length L1 mm	Connecting Pin Length L2 mm	Inner Plate		Outer Plate	
	inch	metric								H1 mm	T1 mm	H2 mm	T2 mm
6000	2.0	50.80	15.24	31.75	18.00	10.0	14.27	40.2	40.6	25.0	5.0	23.0	5.0
	3.0	76.20											
	4.0	101.60											
	6.0	152.40											
12000	3.0	76.20	19.05	47.62	23.8	13.21	19.05	46.2	49.1	40.0	6.0	40.0	5.0
	4.0	101.60											
	5.0	127.00											
	6.0	152.40											
	8.0	203.20											
24000	4.0	101.60	27.0	66.67	33.0	20.2	27.0	61.2	63.8	50.0	8.0	50.0	6.0
	5.0	127.00											
	6.0	152.40											
	7.0	177.80											
	8.0	203.20											
	9.0	228.60											
	10.0	254.00											
36000	6.0	152.40	38.10	88.90	38.10	23.4	31.75	82.8	86.0	65.0	10.0	65.0	8.0
	8.0	203.20											
	9.0	228.60											
	12.0	304.80											

# High Side Plate Conveyor Chain

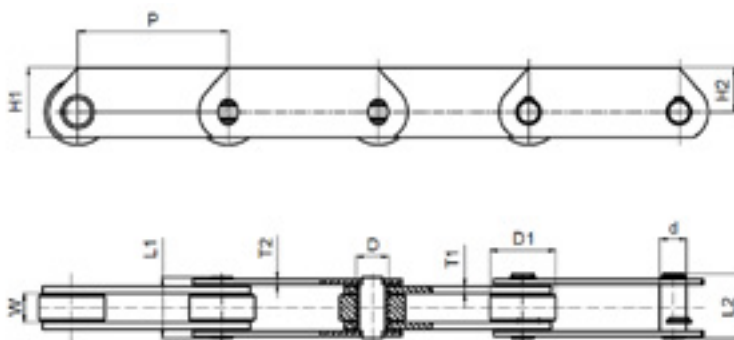

Minimum Breaking Load (lbs)	Pitch P		Roller Width W mm	Roller Diameter d1 mm	Bush Diameter D mm	Solid Pin Diameter d mm	Solid Pin Length L1 (max) mm	Connecting Pin Length L2 (max) mm	Inner Plate		Outer Plate		Average Wt/ft kg
	inch	metric							H1 mm	T1 mm	H2 mm	T2 mm	
7500	2.0	50.80	15.24	31.75	18.00	14.27	40.6	50.8	25.0	5.0	25.0	5.0	2.0
	3.0	76.20											1.7
	4.0	101.60											1.6
	6.0	152.40											1.4
15000	3.0	76.20	19.05	47.62	23.8	19.05	48.26	57.0	40.0	6.0	40.0	6.0	2.7
	4.0	101.60											2.5
	5.0	127.00											2.2
	6.0	152.40											2.0
	8.0	203.20											1.9
30000	4.0	101.60	25.40	66.67	33.0	27.0	61.98	74.0	50.0	8.0	50.0	6.0	5.1
	5.0	127.00											4.5
	6.0	152.40											4.1
	7.0	177.80											3.8
	8.0	203.20											3.3
	9.0	228.60											3.4
	10.0	254.00											???
	12.0	304.80											3.2
45000	6.0	152.40	38.10	88.90	38.10	31.75	84.13	110.5	65.0	10.0	65.0	8.0	8.2
	8.0	203.20											—
	9.0	228.60											—
	12.0	304.80											—
60000	6.0	152.40	38.10	88.90	38.10	31.75	84.13	110.5	65.0	10.0	65.0	8.0	8.1
	9.0	228.60											6.6
	12.0	304.80											5.5
85000	6.0	152.40	38.10	88.90	38.10	31.75	82.86	118.4	65.0	12.0	65.0	10.00	10.7
	9.0	228.60											???
	12.0	304.80											8.3

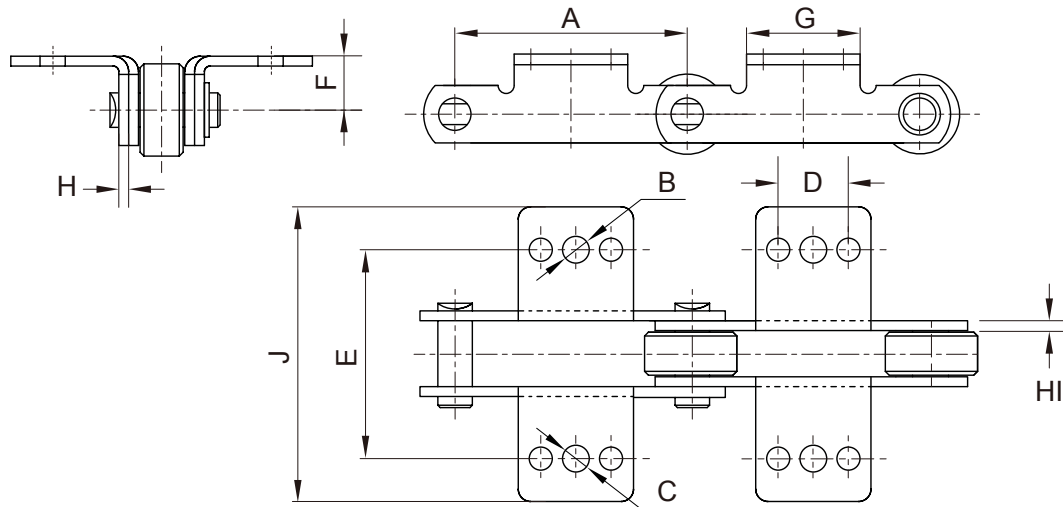

Chain Breaking Load		Attachment Holes						Platform Details					Extra Weight Link/kg
Hollow Pin	Solid Pin	Pitch A	Number Holes	Diameter		Centres		Height F	Length G	Thick		Clearance J	
				B	C	D	E			H	HI		
6,000	7,500	2	1	10.7	—	—	76.2	19	35.7	5	5	102.8	0.04
6,000	7,500	3	3	10.7	9.2	31.7	76.2	19	51.5	5	5	102.8	0.05
6,000	7,500	4	3	10.7	9.2	32.1	76.2	19	61.3	5	5	102.8	0.08
6,000	7,500	6	3	10.7	9.2	57.1	76.2	19	76.5	5	5	102.8	0.14
12,000	15,000	3	3	13.8	10.7	31.7	88.9	31.7	69.8	5	6	127.0	0.10
12,000	15,000	4	3	13.8	10.7	31.7	88.9	31.7	67.8	5	6	152.4	0.12
12,000	15,000	6	3	13.8	10.7	56.1	88.9	31.7	102.7	5	6	152.4	0.18
24,000	30,000	6	3	13.8	12.3	56.1	107.9	38.1	83.8	6	8	171.4	0.23
24,000	30,000	9	2	—	12.3	114.3	107.9	38.1	152.4	6	8	171.4	0.52

# Bush Steel Conveyor Chain

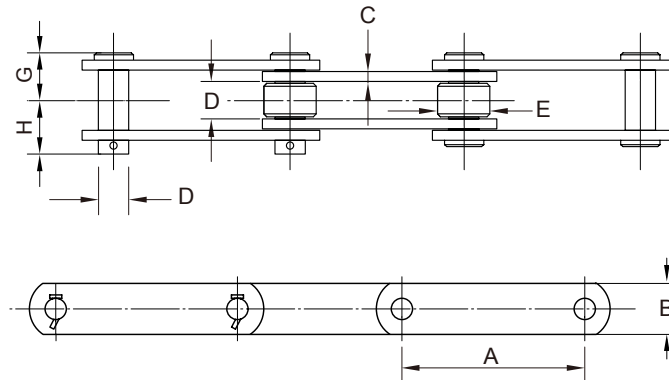

Chain No.	Pitch	Plate Height						
	A	B	C	D	E	F	G	h
S188	66.27	28.50	6.00	12.70	22.30	25.40	34.30	36.80
S131	78.11	40.00	10.00	15.90	31.75	32.30	45.70	48.30
S102B	101.60	40.00	10.00	15.90	25.40	54.00	59.70	62.20
S102B	120.90	45.00	10.00	19.00	36.50	66.70	66.00	68.60
S102B	152.40	40.00	10.00	15.90	31.75	54.00	55.90	58.40

## Bush Steel Conveyor Chain Attachments

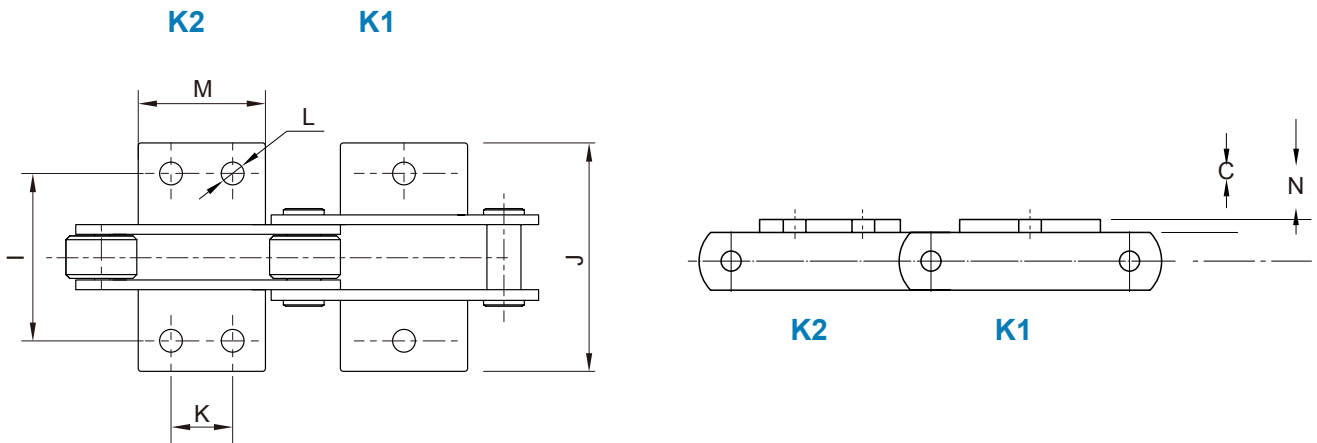

Chain No.	Pitch						
	A	I	J	K	L	M	N
S188	66.27	106.38	146	31.75	9.5	55.1	20.6
S131	78.11	104.78	137	38.1	14.3	65	24.5
S102B	101.60	134.95	171.5	44.5	11.1	74.9	25.4
S111	120.90	158.75	213.4	58.8	13.4	89	28.6
S110	152.40	134.95	177.8	44.5	11.1	74.9	25.4

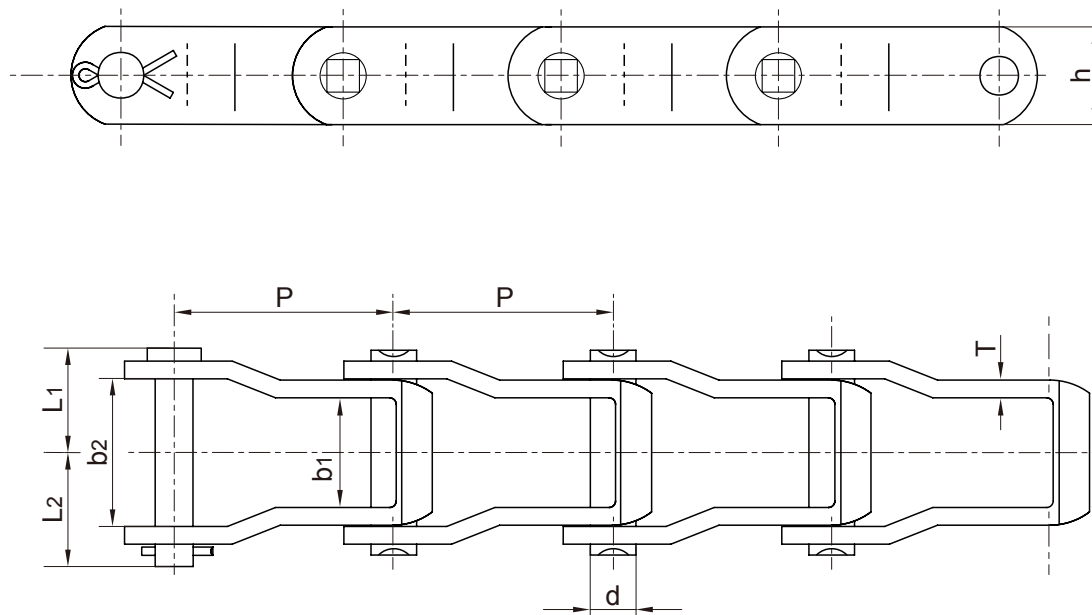

Chain No.	Pitch P mm	Pin Diameter d2 mm	Width Between Inner Plates b1 mm	Pin Length		Inner Plate Depth h2 max mm	Plate Thickness T mm	Ultimate Tensile Strength Q min kN	Weight Per Metre q kg/m
				L max mm	L1 max mm				
205	31.75	5.08	9.80	21.20	24.20	12.20	2.06	12.50	0.64
662	42.27	7.15	23.2	40.35	44.00	18.30	3.20	37.80	1.71
667H	58.75	7.92	25.6	43.05	47.00	22.23	3.20	42.30	1.85
667J	57.15	9.53	27.00	49.65	54.50	23.80	4.30	62.28	2.27
667K	57.15	11.1	27.80	54.50	58.85	26.80	5.10	89.00	3.88
667X	57.15	11.1	27.00	50.00	54.80	23.80	4.30	66.70	2.96
88K	66.27	11.1	27.80	54.50	58.85	26.80	5.10	89.00	3.64
667XH	57.15	11.9	27.80	57.40	61.25	26.80	5.70	124.6	4.44



# Cast Iron Chains

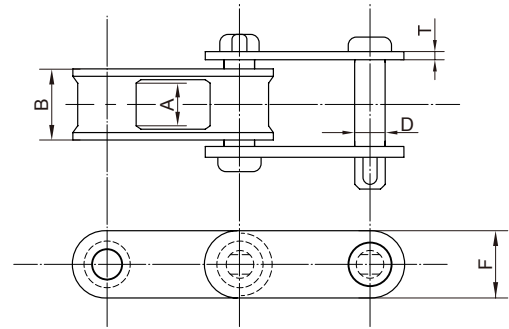

Chain No.	Average Pitch		Max Allow Load Lbs.	Average Ultimate Tensile Strength Lbs.	Nos. of Chain Per 10 Feet	Average Weight kg/ft.	Dimensions (mm)				
	in.	mm					A	B	D	F	T
C55	1.631	41.4274	1110	9000	74	0.97	17.5	32	9.5	19	4.8
C55L	1.631	41.4274	1110	9000	74	1.25	17.5	32	10	19	4.8
C77	2.308	58.6232	1360	11000	52	1.03	17.5	32	11.1	22	4.8
C188	2.609	66.2686	1950	14000	46	1.60	23.8	39.6	12.7	29	5.8
C188L	2.609	66.2686	1950	14000	46	1.60	23.8	39.6	14.3	29	5.8
C102B	4.000	101.6	4000	24000	30	2.85	50.8	73	16	38	9.0
C111	4.760	120.904	5950	36000	26	5.60	60	86	19	44	9.0
C131	3.075	78.105	3220	24000	40	3.30	28.5	52	16	38	9.0
C132	6.000	152.4	8330	50000	20	6.57	73	111	25.4	50.8	12

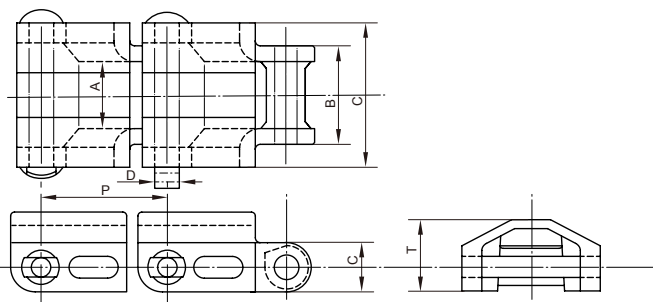
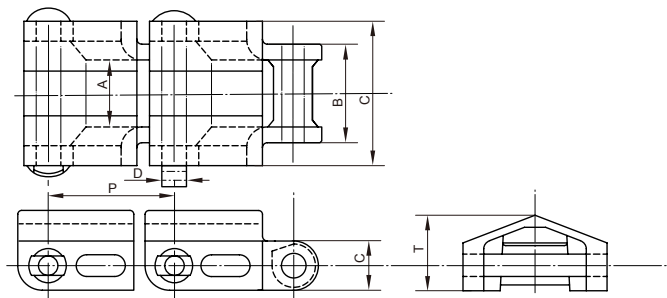

Chain No.	Style	Average Pitch		Max Allow Load Lbs.	Average Ultimate Tensile Strength Lbs.	Nos. of Chain Per 10 Feet	Average Weight kg/ft.	Dimensions (mm)					
		in.	mm					A	B	C	D	E	F
H78A	A	2.609	66.2686	2200	12600	46	2.72	28.6	47	71	12.7	25.4	43
H78B	B	2.609	66.2686	2200	12600	46	2.85	28.6	47	71	12.7	25.4	43
H130	A	4.000	101.6	2500	15000	30	2.52	25.4	43	71	12.7	25.4	43
H138	B	4.000	101.6	2500	15000	30	2.67	25.4	43	71	12.7	25.4	43

Pintel Chains

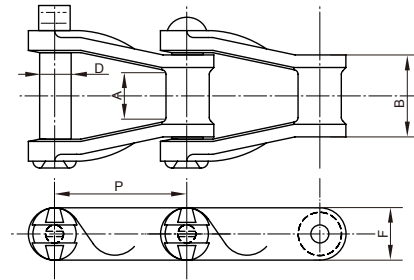

Chain No.	Average Pitch		Max Allow Load Lbs.	Average Ultimate Tensile Strength Lbs.	Nos. of Chain Per 10 Feet	Average Weight kg/ft.	Dimensions (mm)			
	in.	mm					A	B	D	F
H60	2.308	58.6232	1170	7000	52	0.96	19	38	8	19
H78	2.609	66.2686	2100	12600	46	1.84	28.5	76.7	12.7	28.5
H82	3.075	78.105	2700	17000	39	2.45	32	55	14	32
H110	6.000	152.4	4200	24500	20	5.90	235	270	19	38

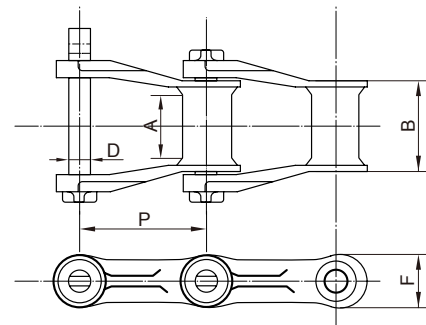

Chain No.	Average Pitch		Max Allow Load Lbs.	Average Ultimate Tensile Strength Lbs.	Nos. of Chain Per 10 Feet	Average Weight kg/ft.	Dimensions (mm)			
	in.	mm					A	B	D	F
462	1.634	41.5036	1400	9000	73	1.19	22	36.5	11.1	22
477	2.308	58.6232	1200	9600	52	1.03	17.5	32	11.1	25.4
488	2.609	66.2686	1600	11000	46	1.33	24	41	11.1	24
4103	3.075	78.105	3200	22000	39	2.59	28.5	47.6	19	38
720	6.000	152.4	3200	22000	20	1.90	28.5	47.6	17.5	38
720S	6.000	152.4	3300	29000	20	2.35	28.5	47.6	19	38
730	6.000	152.4	3500	30000	20	3.0	28.5	50	19	44

Offset Siderbar

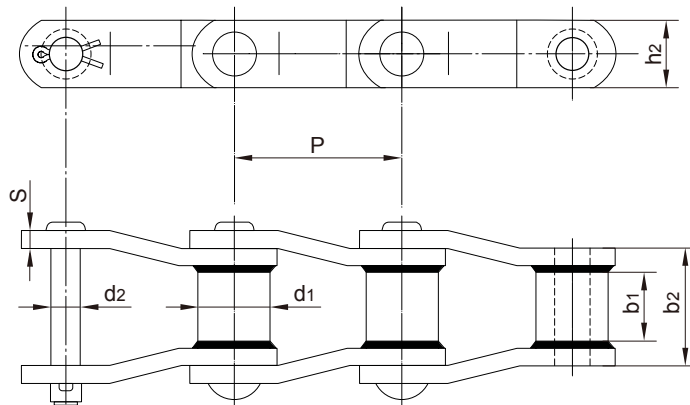

Chain No.	Pitch P mm	Outside Barrel Diameter d1 (max) mm	Pin Diameter d2 (max) mm	Side Bar Height h2 (max) mm	Approx. Tooth Face at Pitch Line b1 (max) mm	Length of Bearing b2 (max) mm	Plate Thickness S (max) mm	Breaking Load Q mm	Weight Approx. q mm
WR78	66.27	22.23	12.70	28.40	31.75	51.00	6.40	93.4	1.9
WH78	66.27	22.23	12.70	28.40	31.75	51.00	6.40	146	1.9
WR82	78.10	26.97	14.35	31.80	38.10	57.40	6.40	100.1	2.28
WH82	78.10	26.97	14.35	31.80	38.10	57.40	6.40	132	2.28
WR124	101.60	31.75	19.05	38.10	41.28	70.30	9.70	169.0	3.62
WH124	101.60	31.75	19.05	38.10	41.28	70.30	9.70	307	3.62
WR111	120.90	31.75	19.05	44.45	57.15	86.20	9.70	169.0	4.17
WH111	120.90	31.75	19.05	44.45	57.15	86.20	9.70	266.7	4.17
WR106	152.40	31.75	19.05	38.10	38.10	69.85	9.70	169.0	3.0
WH106	152.40	31.75	19.05	38.10	38.10	69.85	9.70	250	3.0
WR110	152.40	31.75	19.05	38.10	38.10	69.85	9.70	169.0	3.0
WH110	152.40	31.75	19.05	38.10	38.10	69.85	9.70	250	3.0
WR132	153.67	44.45	25.40	50.80	73.00	111.0	12.70	275.8	6.43
WH132	153.67	44.45	25.40	50.80	73.00	111.0	12.70	511	6.43
WR150	153.67	44.45	25.4	63.50	73.0	111.0	12.70	620	7.74
WH150	153.67	44.45	25.4	63.50	73.0	111.0	12.70	620	7.74
WR155	153.67	44.45	28.57	63.50	73.0	117.48	15.88	820	9.0
WH155	153.67	44.45	28.57	63.50	73.0	117.48	15.88	820	9.0
WR157	153.67	44.45	28.57	63.50	76.2	117.48	15.88	820	9.1
WH157	153.67	44.45	28.57	63.50	76.2	117.48	15.88	820	9.1

**Straight Siderbar**

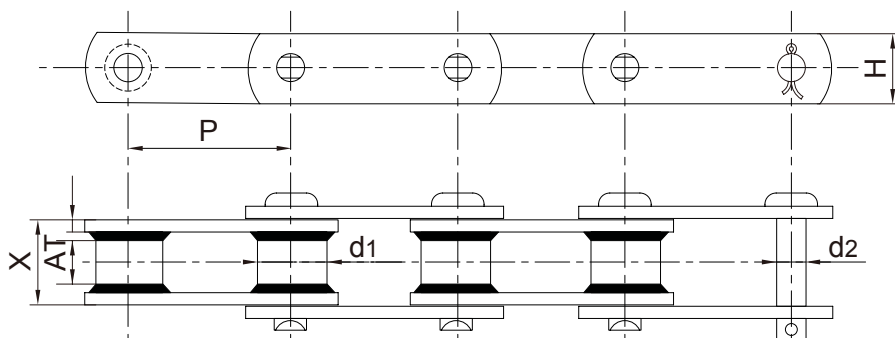

Chain No.	Pitch P mm	Outside Barrel Diameter d1 (max) mm	Pin Diameter d2 (max) mm	Side Bar Height h2 (max) mm	Approx. Tooth Face at Pitch Line b1 (max) mm	Length of Bearing b2 (max) mm	Plate Thickness S (max) mm	Breaking Load Q mm	Weight Approx. q mm
WRC-131	78.10	31.75	19.05	57.15	28.58	38.10	9.70	224	3.83
WHC-131	78.10	31.75	19.05	57.15	28.58	38.10	9.70	255	3.60
WRC-124	101.60	32.00	19.05	71.00	43.00	40.00	10.00	225	4.13
WRC-111	120.90	31.75	19.05	86.20	57.15	44.45	9.70	224	3.20

**Straight Siderbar**

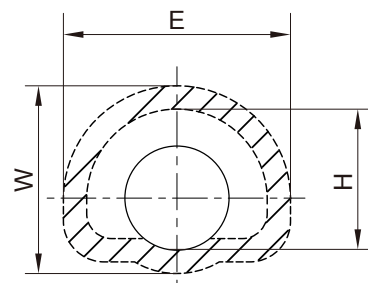
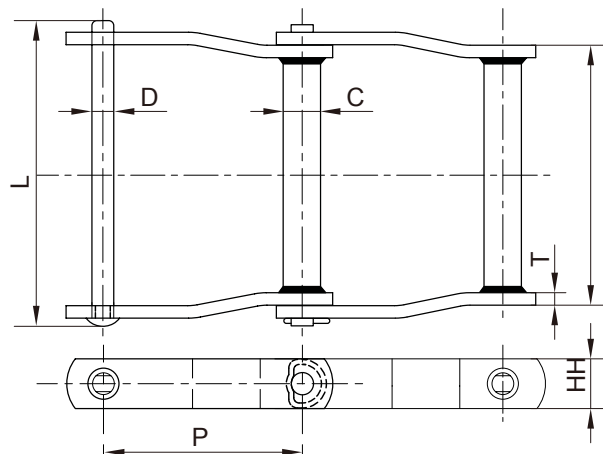

Chain No.	Pitch P mm	Outside Barrel Dia. C mm	Side Bar Height H mm	Plate Thickness T mm	Maximum Sprocket Bearing A (min) mm	Length of Bearing X (max) mm	Pin Dimensions		Barrel Sectional Dimensions			Breaking Load Q mm	Weight Approx. q mm
							D mm	L mm	B mm	E mm	W mm		
WD102	127	38.1	38.1	9.7	162	197.1	19.05	233	19.7	38.1	31.7	226	5.47
WDH104	152.4	38.1	38.1	9.7	104.8	136.53	19.05	173	19.7	38.1	31.7	226	4.56
WD110	152.4	38.1	38.1	9.7	235	264	19.05	296	19.7	38.1	31.7	250	5.75
WD112	203.2	38.1	38.1	9.7	228.6	260.5	19.05	296	19.7	38.1	31.7	170	4.7
WD113	152.4	38.1	38.1	12.7	228.6	270.2	22.23	311	22.8	38.1	33.2	297	7.0
WD116	203.2	44.45	44.45	9.7	330.2	358.8	19.05	395	23.65	44.45	36.65	250	6.72
WD480	203.2	50.8	50.8	12.7	280	323.85	22.23	367	28.5	50.8	44.5	311	9.07

Extra Heavy Duty

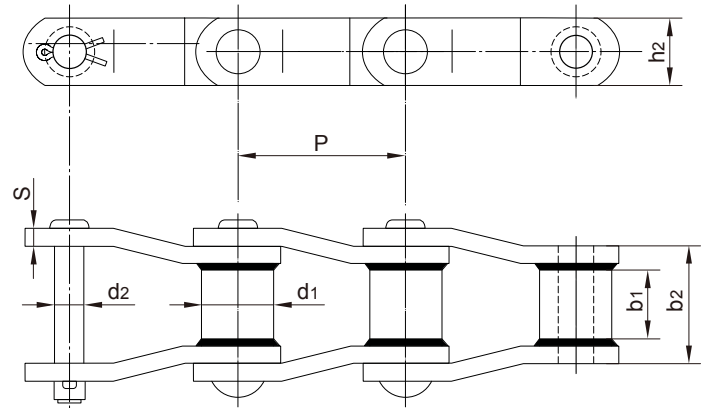

Chain No.	Pitch P mm	Outside Barrel Diameter d1 (max) mm	Pin Diameter d2 (max) mm	Side Bar Height h2 (max) mm	Approx. Tooth Face at Pitch Line b1 (max) mm	Length of Bearing b2 (max) mm	Plate Thickness S (max) mm	Breaking Load Q mm	Weight Approx. q mm
WR78XHD	66.95	25.4	14.29	31.75	25.4	50.8	9.5	133	2.82
WH78XHD	66.95	25.4	14.29	31.75	25.4	50.8	9.5	160	2.82
WR82XHD	78.1	31.75	19.05	38.1	28.6	60.9	9.7	144.8	3.85
WH82XHD	78.1	31.75	19.05	38.1	28.6	60.9	9.7	253	3.85
WR124XHD	103.2	44.45	25.4	50.8	38.1	76.2	12.7	378	6.73
WH124XHD	103.2	44.45	25.4	50.8	38.1	76.2	12.7	542	6.73
WR106XHD	153.67	44.45	25.4	50.8	38.1	76.2	12.7	378	5.52
WH106XHD	153.67	44.45	25.4	50.8	38.1	76.2	12.7	542	5.52
WR132XHD	153.67	44.45	25.4	50.8	76.2	118.6	15.88	534	7.49
WH132XHD	153.67	44.45	25.4	50.8	76.2	118.6	15.88	543	7.49

# Specialised Engineered Chains

Specialised engineered conveyor chains are highly advanced and purpose-built chains designed to meet the demanding requirements of various industrial applications. These chains are specifically engineered to provide exceptional performance, reliability, and longevity.

Specialised engineered conveyor chains cater to the unique requirements of various industries, ensuring efficient and reliable material handling. These chains are designed with specific features and materials to withstand challenging operating conditions, improve productivity, and prolong service life in their respective applications.



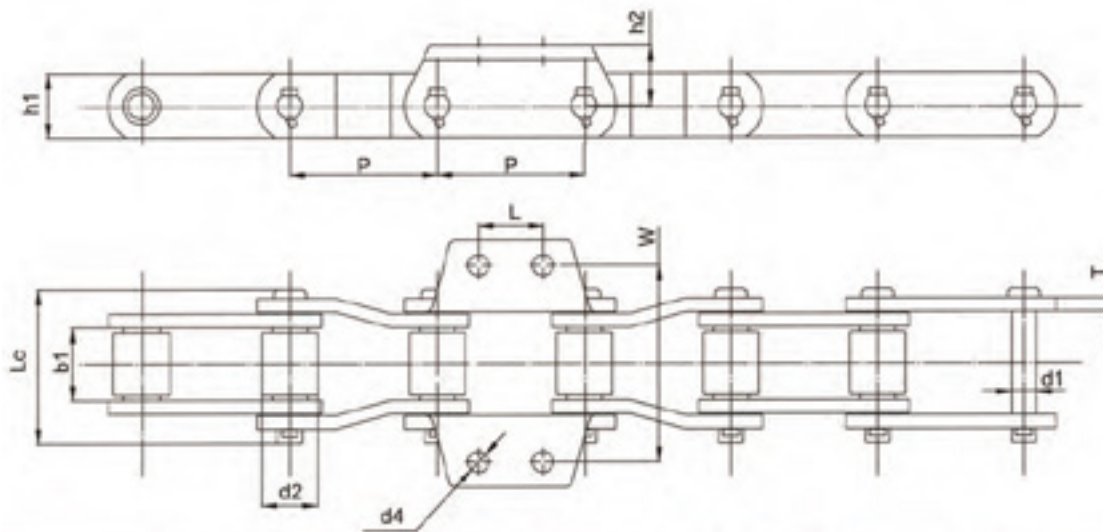

Chain No.	Pitch	Width Between Inner Plates	Roller Diameter	Pin Diameter	Pin Length	Plate Depth	Plate Thickness	Plate Dimensions				Ultimate Tensile Strength
	P	b1	d2	d1	Lc	h1	T	d4	W	h2	L	Q
	mm	mm	mm	mm	mm	mm	mm	mm	mm	mm	mm	kN
P15491	101.6	50.4	38.1	17.5	108	44.5	9.5	14.2	134.9	41.4	44.5	290
S2035	131.78	58.8	50.8	22.23	117	63.5	9.5	14.3	158.8	50.8	58.7	320

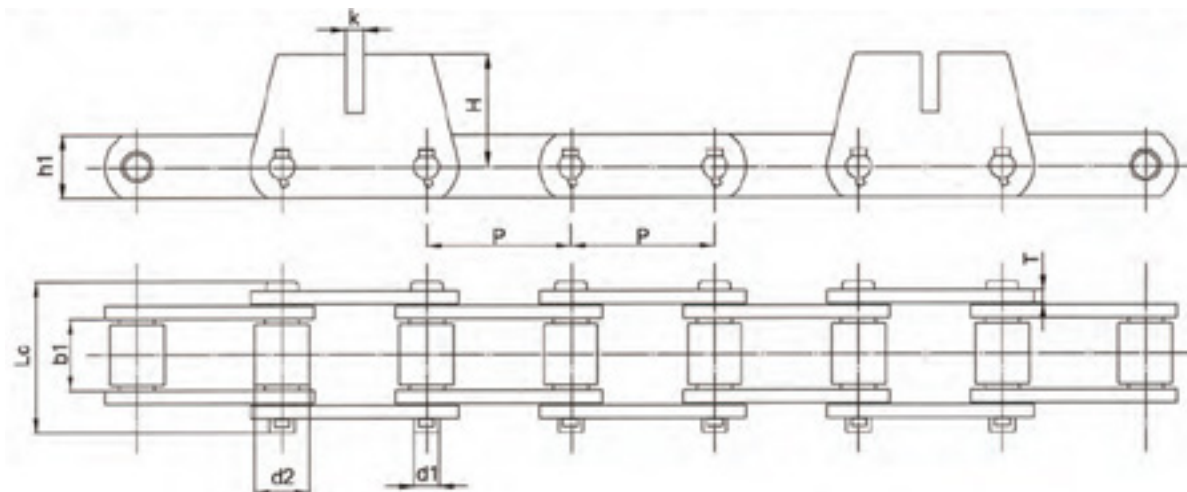

Chain No.	Pitch P	Width Between Inner Plates	Roller Diameter	Pin Diameter	Pin Length	Plate Depth	Plate Thickness	Attachment Dimensions		Ultimate Tensile Strength
	mm	b1 mm	d2 mm	d1 mm	Lc mm	h1 mm	T mm	H mm	K mm	Q kN
P15517	78.1	37.8	31.75	15.88	93.4	38.1	9.5	63.55	12.5	266.7
P15582	101.6	50.4	38.1	17.5	121	44.5	12.7	79.35	16.5	355.6
C9856M2	152.4	76.2	69.85	25.4	152	63.5	12.7	120.6	20.6	622.3
C9856M1	152.4	76.2	69.85	25.4	152	63.5	12.7	95.2	20.6	622.3



The S / MR Series and CA Series agricultural chains are available with a diverse selection of attachments, coatings, materials, slats, and pushers to meet various agricultural needs.

## S / MR type (Waisted Side Plate)

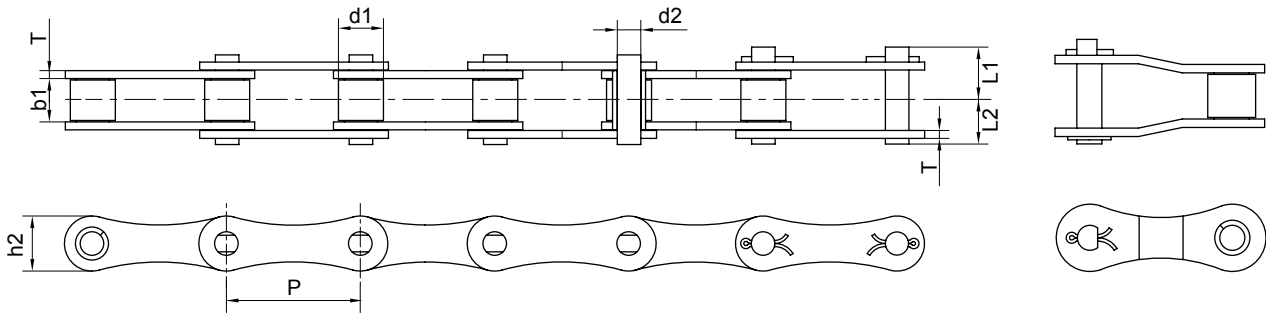

## CA type (Straight Side Plate)

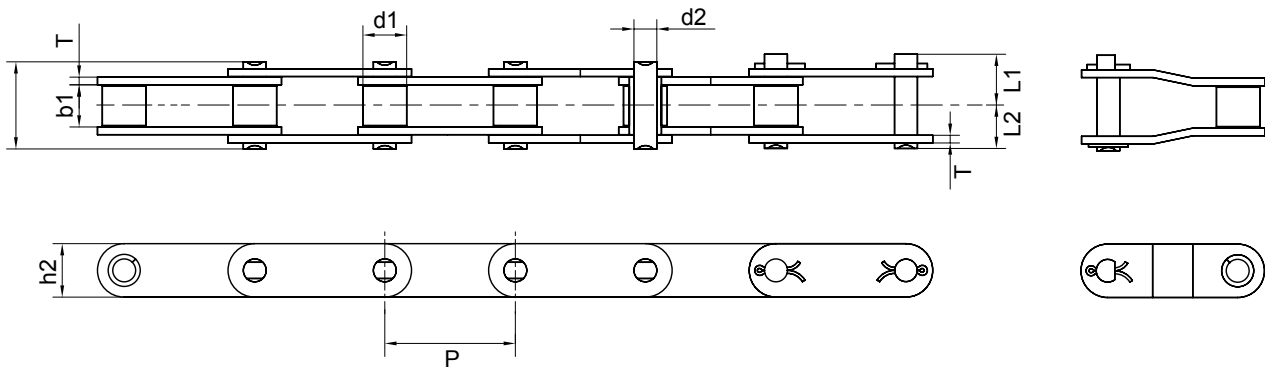

Chain No.	Pitch P mm	Roller Diameter d1 mm	Width Between Inner Plates b1 mm	Pin			Plate		Ultimate Tensile Strength Q min kgf	Weight Per Metre q = kg/m
				d2 mm	L1 mm	L2 mm	T mm	h2 mm		
S32 / MR32	29.21	11.43	15.9	4.44	14.45	13.05	1.5	12.8	900	0.75
S42 / MR42	34.93	14.27	19.1	7.00	19.05	16.85	2.5	19.0	3000	1.61
S52 / MR52	38.10	15.24	22.2	5.72	20.80	18.40	2.5	16.4	2000	1.57
S55 / MR55	41.40	17.78	22.2	5.72	20.80	18.40	2.5	16.6	2000	1.64
S45 / MR45	41.40	15.24	22.2	5.72	20.80	18.40	2.5	16.6	2000	1.44
S62 / MR62	41.91	19.05	25.4	5.72	20.75	20.05	2.5	16.8	2900	1.87
S77 / MR77	58.34	18.26	22.23	8.90	27.8	21.6	4.0	26.2	4590	2.65
S88 / MR88	66.27	22.86	28.58	8.90	28.1	24.9	4.0	26.2	4590	3.25
CA550	41.40	16.80	20.2	7.15	20.85	17.35	2.7	20.0	5100	1.95
CA557	41.4	17.79	20.2	6.0	22.2	18.7	3.2	23.1	5560	2.2
CA620	42.01	17.68	25.0	7.15	24.15	21.05	3.2	20.0	5100	2.38

# Agricultural Chain Attachments

The agricultural roller chain offers exceptional versatility with a wide range of attachments, making it ideal for use in harvesters, balers, and various agricultural equipment.

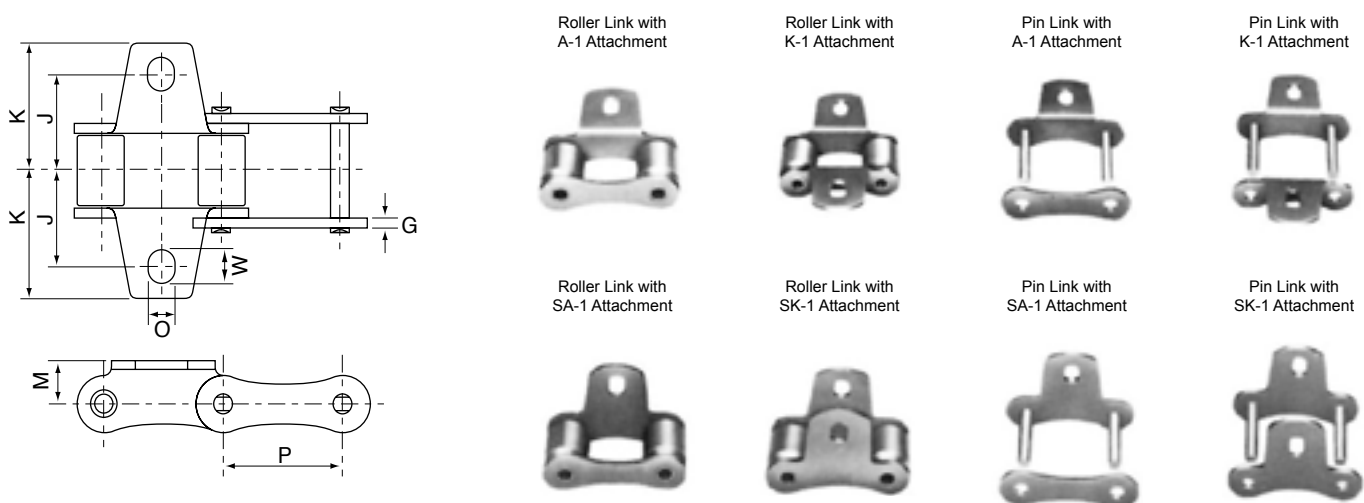

Chain No.	Pitch P mm	G mm	J mm	K mm	M mm	O mm	W mm
S32	29.21	1.80	21.50	30.50	8.60	5.30	6.90
S42	34.93	2.80	27.00	37.45	14.00	8.30	11.50
S45	41.40	2.80	27.00	37.50	11.40	8.50	11.70
S52	38.10	2.80	29.40	39.00	11.40	8.30	9.90
S55	41.40	2.80	27.00	37.50	11.40	8.50	11.70
S62	41.91	2.50	33.40	47.70	11.40	6.50	13.00
S77	58.34	4.00	38.10	50.80	20.80	8.40	11.70
S88	66.27	4.00	48.50	59.70	20.80	8.40	10.00

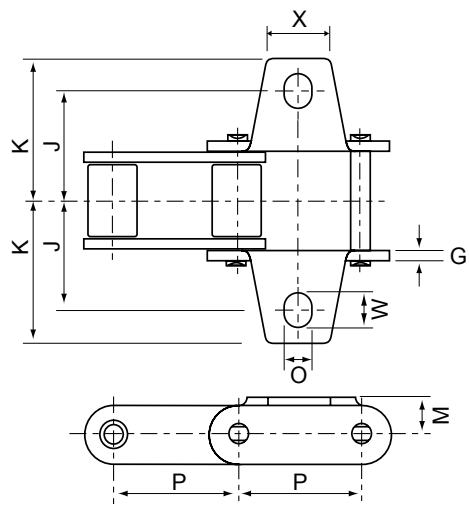

Chain No.	P mm	G mm	J mm	K mm	M mm	O mm	w mm	X mm
CA550K1	41.40	2.80	26.25	38.10	12.70	8.30	10.00	22.00
CA557K1	41.40	3.10	25.40	36.00	15.90	8.70	-	-

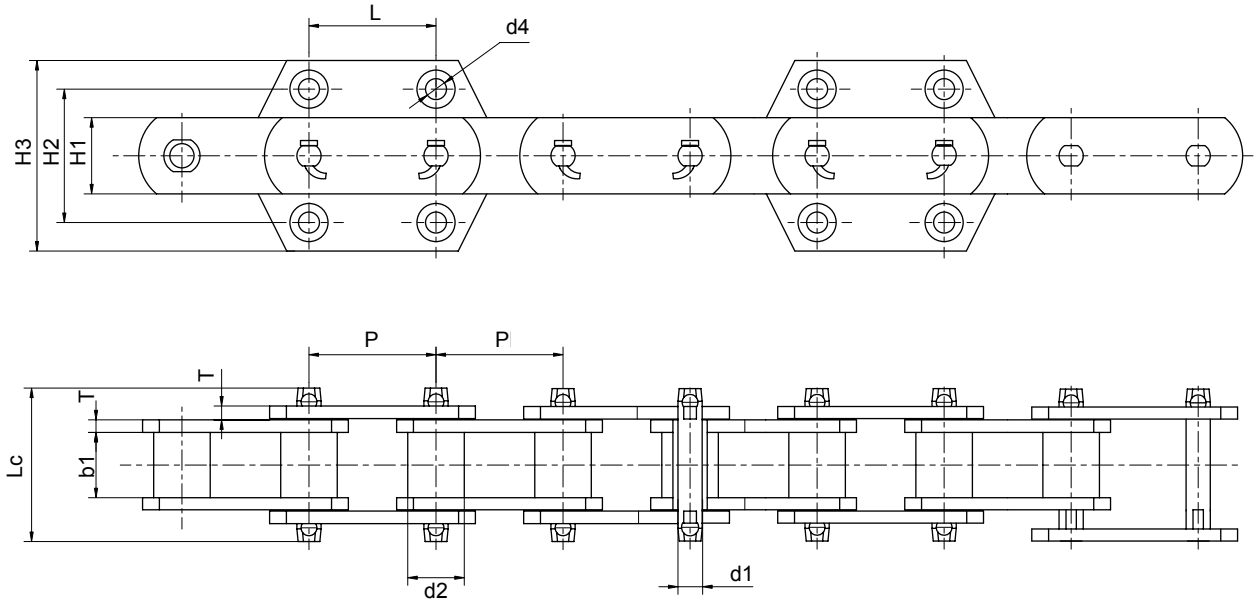

Conveyor Type	Chain No.	Pitch P mm	Roller Diameter d2 mm	Width Between Inner Plates b1 mm	Pin Diameter d1 mm	Pin Length Lc mm	Plate Depth H1 mm	Plate Thickness T mm	Attachment Dimension				Weight Per Metre Q min kN
									H3 mm	H2 mm	L mm	d4 mm	
—	P100F112.04	100.0	44.5	52.0	19.30	120.0	60.0	10.0	150	105	100	18.5	350.0
	P100F107.04	100.0	50.8	58.0	25.40	120.0	75.0	10.0	150	105	100	18.5	550.0
NE15	P101.6F92	101.6	26.5	27.0	11.50	70.0	35.0	6.0	90	40	12.0	100.0	12.90
NE30	P152F119	152.4	36.0	36.5	15.50	90.0	50.0	8.0	120	60	14.0	240.0	11.20
NES0	P152F120	152.4	36.0	36.5	15.50	90.0	50.0	8.0	110	70	75	14.0	240.0
—	P152F126	152.4	34.9	37.1	15.80	88.0	44.5	7.9	110	70	75	15.0	186.2
NE100	P200F64	200.0	44.5	51.8	19.10	120.0	60.0	10.0	125	80	100	18.0	380.0
NE150	P200F65	200.0	48.5	57.6	22.20	120.0	75.0	10.0	125	80	100	18.0	550.0
—	P200F63	200.0	48.5	57.6	22.20	125.0	75.0	10.0	125	80	100	18.5	315.0
NE200	P250F42	250.0	63.5	67.4	31.75	143.0	90.0	12.0	150	100	140	18.0	750.0
NE300	P250F43	250.0	63.5	67.4	31.75	146.0	90.0	12.0	150	100	140	18.0	750.0
NE400	P300F9	300.0	70.0	75.0	35.00	170.0	100.0	16.0	180	125	170	22.0	1065.0

# Car Parking Chain

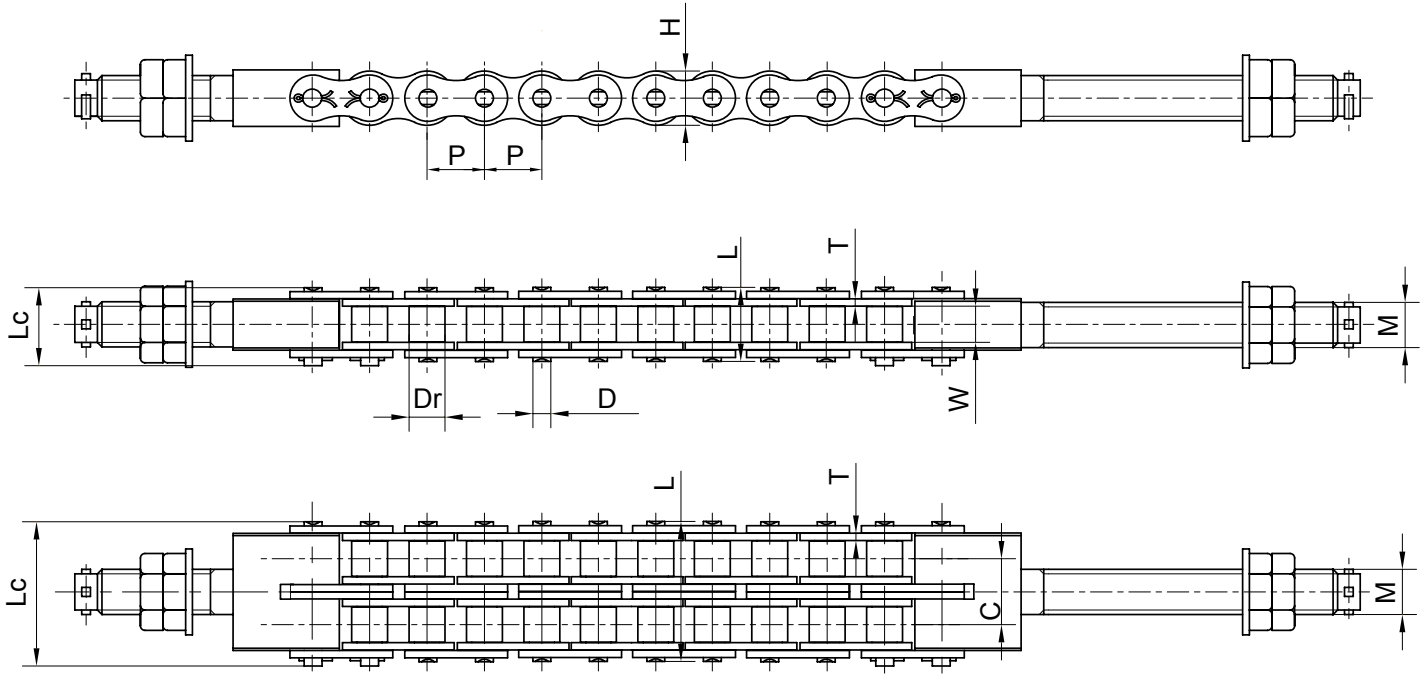

Chain No.	Pitch P mm	Roller Diameter max Dr mm	Width Between Inner Plates min W mm	Pin Diameter max D mm	Plate Thickness max T mm	Inner Plate Depth max H mm	Pin Length		Type of Bolt M mm	Transverse Pitch C mm	Average Tensile Strength kN	Tensile Strength min kN	Weight Per Metre kg/m
							L max mm	Lc max mm					
16ALT-1	25.4	15.88	15.75	7.94	3.25	24.13	33.5	36.0	M20	29.29	72.0	55.6	2.7
16ALT-2							62.7	65.25	M20		142.0	111.2	5.32
20ALT-1	31.75	19.05	18.9	9.54	4.00	30.18	41.1	43.4	M24	35.76	110.2	86.7	4.0
20ALT-2							77.0	79.3	M24		220.4	173.5	7.87
24ALT-1	38.1	22.23	25.22	11.11	4.80	36.2	50.8	54.3	M30	45.44	157.2	124.6	5.65
24ALT-2							96.3	99.75	M30		314.4	249.1	11.73

# Coupling Chain

A coupling chain is characterised by the use of a common chain between two couplings. This meshes with two parallel sprockets, making it suitable for high-speed and heavy-duty power transmission. Some couplings also include buffers and reductions to address vibration and improve the dynamic performance of the shaft system.

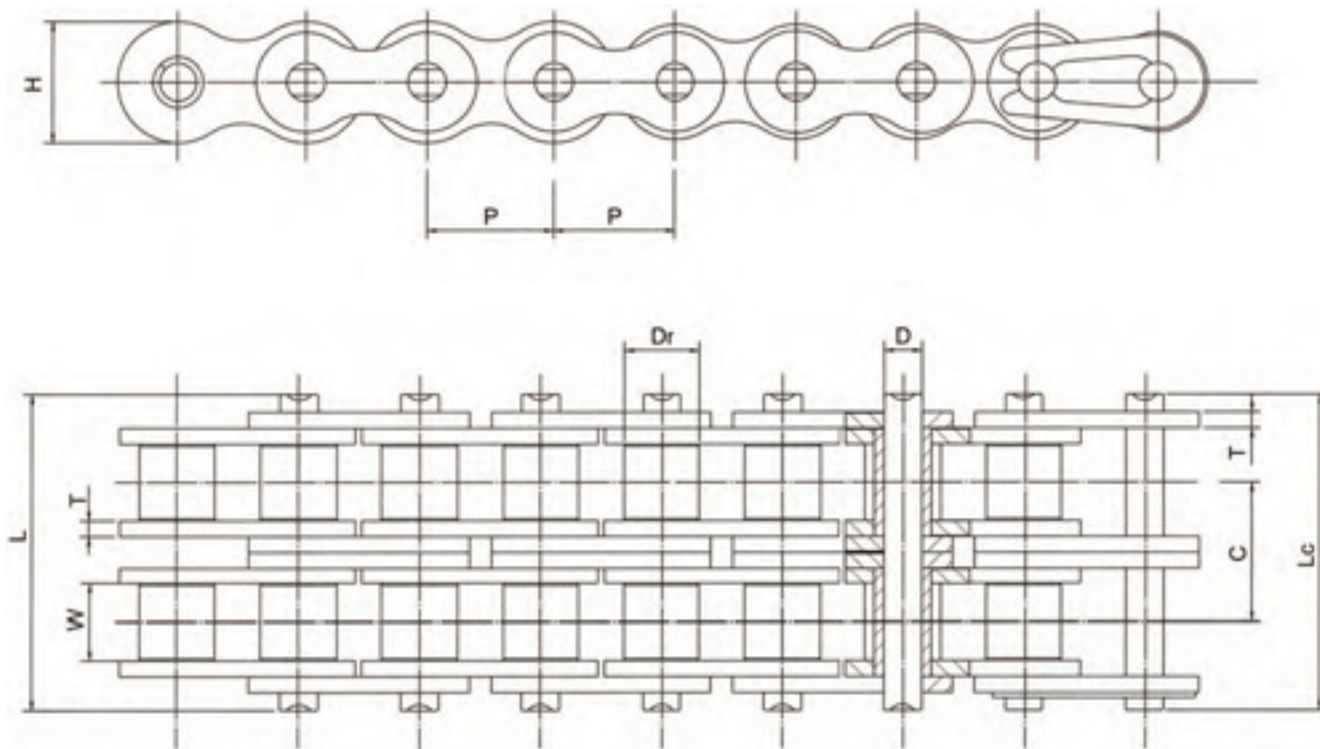

Chain No.	Pitch P mm	Roller Diameter max Dr max mm	Width Between Inner Plates min W min mm	Pin Diameter max D max mm	Plate Thickness max T max mm	Inner Plate Depth max H max mm	Pin Length		Transverse Pitch C mm	Average Tensile Strength kN	Tensile Strength min kN	Weight Per Metre kg/pc
							L max mm	Lc max mm				
4012	12.7	7.92	7.85	3.98	1.5	12.07	32.30	33.30	14.38	35.60	27.60	0.19
4014												0.22
4016												0.26
5014	15.875	10.16	9.40	5.09	2.03	15.09	39.90	41.10	18.11	58.40	43.60	0.44
5016												0.51
5018												0.57
6018	19.05	11.91	12.57	5.96	2.42	18.08	49.80	51.15	22.78	83.20	62.30	1.04
6020												1.16
6022												1.28
8020	25.40	15.88	15.75	7.94	3.25	24.13	62.70	65.25	29.29	142.00	111.20	2.70
8022												2.97
8024												3.24
10022	31.75	19.05	18.90	9.54	4.00	30.18	77.00	82.10	35.76	220.40	173.50	5.49
12018	38.10	22.23	25.22	11.11	4.80	36.20	96.30	103.55	45.44	314.40	249.10	8.04
12022												9.83

# Mesh Belt Furnace Hoisting Chain

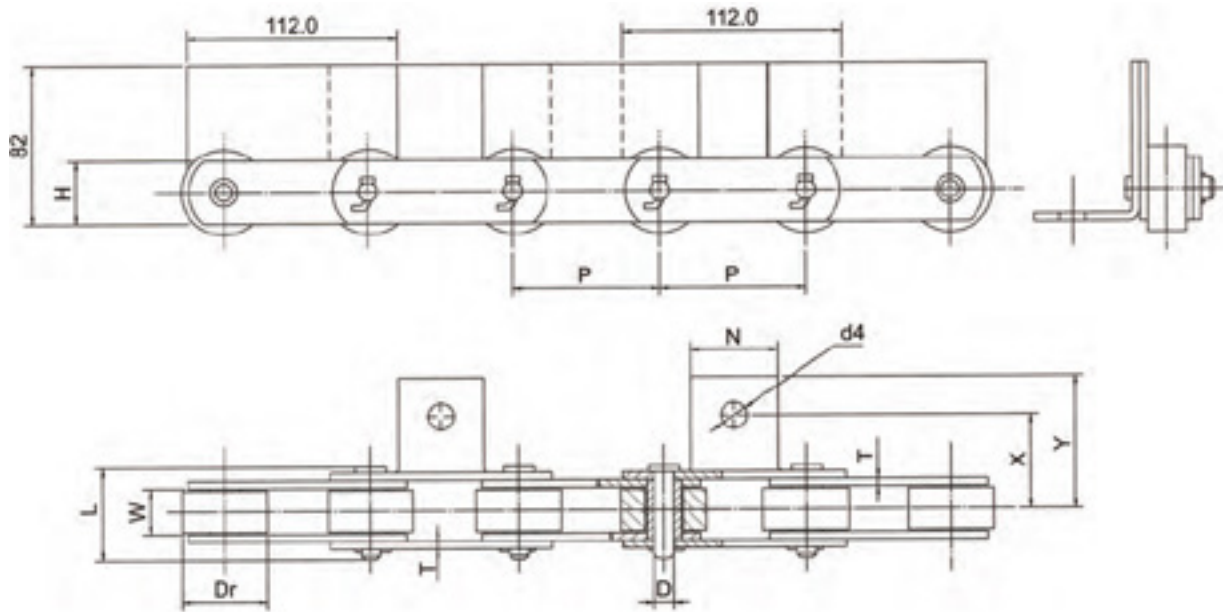

Chain No.	Pitch P mm	Roller Diameter Dr max mm	Width Between Inner Plates W min mm	Pin Diameter D max mm	Pin Length L max mm	Inner Plate Depth H max mm	Plate Thickness T max mm	P Attachment Dimensions				Ultimate Tensile Strength min kN
								N mm	X mm	Y mm	Y mm	
F752240S1	75.00	40.00	22.00	11.05	52.6	32.60	4.50	44.50	48.75	68.75	10.00	98.00
F752240A1	75.00	40.00	22.00	11.05	52.6	32.60	4.50	55.00	34.75	52.25	10.00	98.00

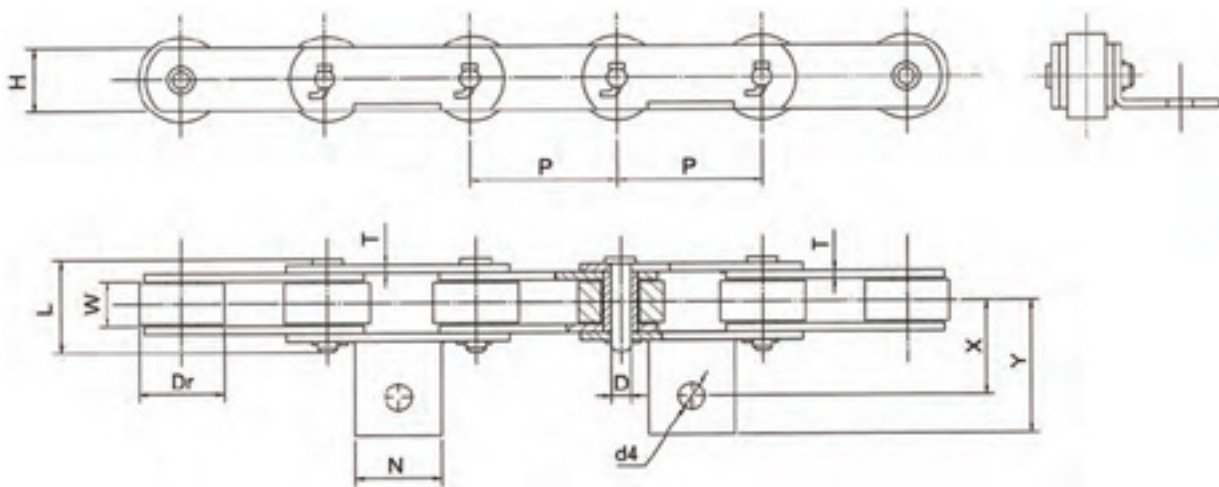

Our oil field chain is a robust, high-quality chain designed for extreme conditions in oil and gas operations. Designed for drilling rigs, wellheads, and pumping units, it's built to endure heavy loads and resist wear, ensuring safe and efficient oil extraction and production.

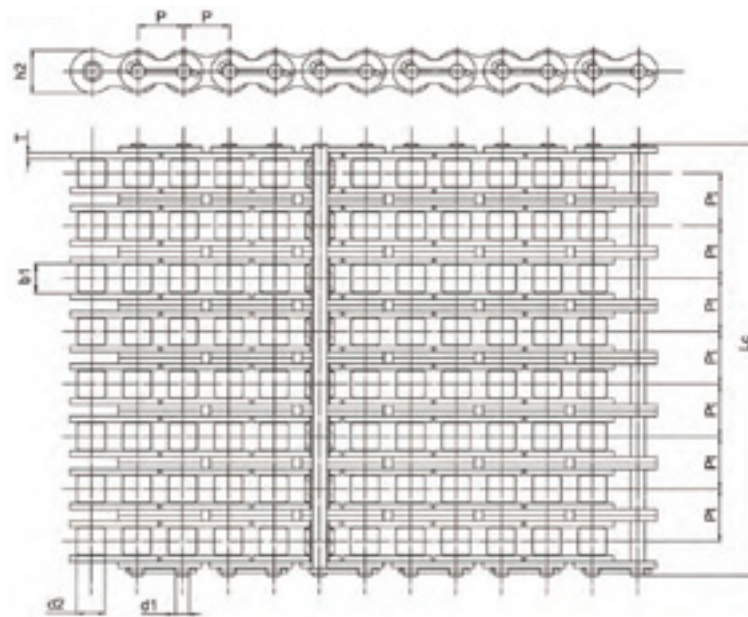

ANSI Chain No.	Type	Pitch P mm		Roller Diameter d2 max mm	Width Between Inner Plates b1 max mm	Pin Diameter d1 max mm	Pin Length Lc max mm	Inner Plate Depth h2 max mm	Plate Thickness T max mm	Transverse Pitch Pt mm	Ultimate Tensile Strength Q min kN	Weight Per Metre q kg/m
80-4	16S-4	25.40	1	15.88	15.75	7.92	122.9	24.1	3.25	29.29	222.4	10.24
100-4	20S-4	31.75	1 1/4	19.05	18.90	9.53	151.5	30.1	4.00	35.76	347.48	15.39
120-4	24S-4	38.10	1 1/2	22.23	25.22	11.10	190.6	36.2	4.80	45.44	500.4	22.19
140-4	28S-4	44.45	1 3/4	25.40	25.22	12.70	205.7	42.2	5.60	48.87	681.08	29.63
160-4	32S-4	50.80	2	28.58	31.55	14.27	245.2	48.2	6.40	58.55	889.6	39.94
200-4	40S-4	63.50	2 1/2	39.68	37.85	19.85	302.0	60.3	8.00	71.55	1390.0	63.60
80-5	16S-5	25.40	1	15.88	15.75	7.92	152.2	24.1	3.25	29.29	278.0	12.79
100-5	20S-5	31.75	1 1/4	19.05	18.90	9.53	187.8	30.1	4.00	35.76	434.35	19.22
120-5	24S-5	38.10	1 1/2	22.23	25.22	11.10	236.1	36.2	4.80	45.44	625.5	27.71
140-5	28S-5	44.45	1 3/4	25.40	25.22	12.70	254.6	42.2	5.60	48.87	851.35	39.20
160-5	32S-5	50.80	2	28.58	31.75	14.27	303.3	48.2	6.40	58.55	1112.0	52.40
80-6	16S-6	25.40	1	15.88	15.75	7.92	181.5	24.1	3.25	29.29	333.6	15.34
100-6	20S-6	31.75	1 1/4	19.05	18.90	9.53	223.6	30.1	4.00	35.76	521.22	23.05
120-6	24S-6	38.10	1 1/2	22.23	25.22	11.10	281.6	36.2	4.80	45.44	750.6	33.24
140-6	28S-6	44.45	1 3/4	25.40	25.22	12.70	303.4	42.2	5.60	48.87	1021.62	44.38
160-6	32S-6	50.80	2	28.58	31.55	14.27	362.3	48.2	6.40	58.55	1334.4	59.86
200-6	40S-6	63.50	2 1/2	39.68	37.85	19.85	445.0	60.3	8.00	71.55	2085.0	95.23
80-8	16S-8	25.40	1	15.88	15.75	7.92	240.1	24.1	3.25	29.29	444.8	20.44
100-8	20S-8	31.75	1 1/4	19.05	18.90	9.53	295.1	30.1	4.00	35.76	694.96	30.71
120-8	24S-8	38.10	1 1/2	22.23	25.22	11.10	372.4	36.2	4.80	45.44	1000.8	44.28
140-8	28S-8	44.45	1 3/4	25.40	25.22	12.70	401.1	42.2	5.60	48.87	1362.16	62.21



# Palm Oil Conveyor Chain

## R type

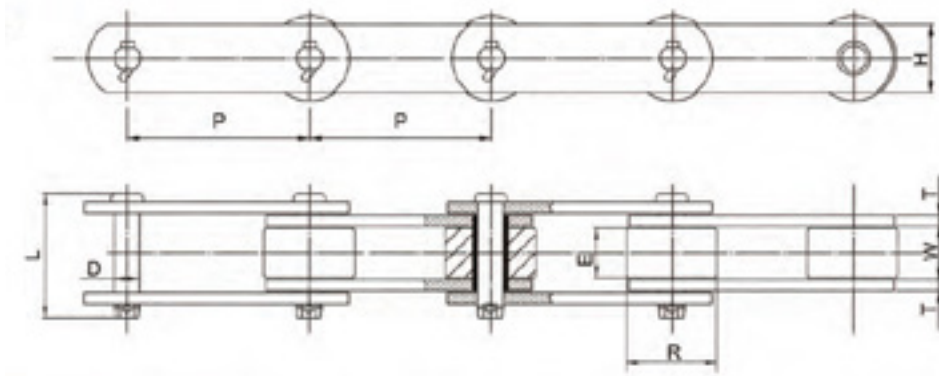

Chain No.	Pitch P	Roller		Inner Width W	Link Plate		Pin		Approx. Weight kg/m	Minimum Break Load	
		Contact E	Diameter R		Height H	Thick T	Dia. D	Length L		kN	kg (lb)
FC90R	101.6	19.5	19.5	22.4	32	4.5	11.1	51.4	5.8	95	9,683 (21,304)
FC94R	101.6	27.5	27.5	30	38.1	6.4	14.3	68.7	9.88	159	16,208 (35,658)
FC604R	152.4	27.5	27.5	30	38.1	6.4	14.3	68.7	7.85	159	16,208 (35,658)
FC05100R	100	19	19	22	32	4.5	11.3	53.2	5.11	75	7,645 (16,820)
FC6205R	152.4	32.3	32.3	37.1	44.5	8	15.9	85	11.87	186	18,960 (41,712)

## F type

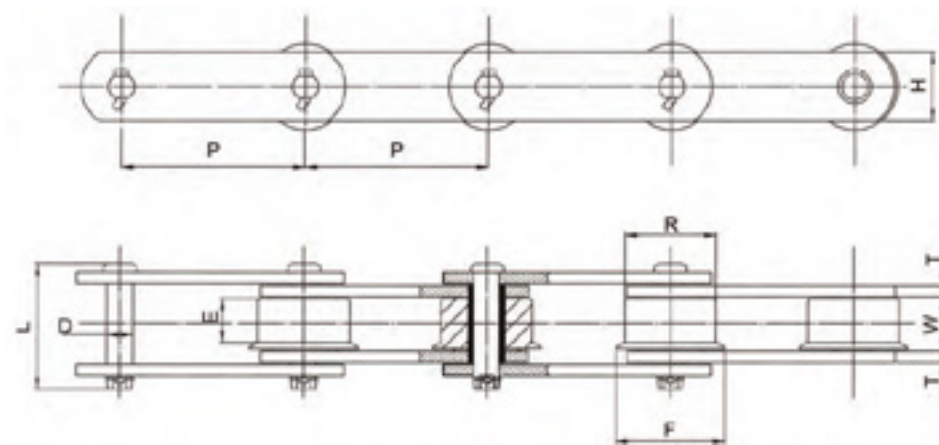

Chain No.	Pitch P	Roller			Inner Width W	Link Plate		Pin		Approx. Weight kg/m	Minimum Break Load	
		Contact E	Diameter R	F		Height H	Thick T	Dia. D	Length L		kN	kg (lb)
FC90R	101.6	14.5	47.6	55	22.4	32	4.5	11.1	51.4	6.05	95	9,683 (21,304)
FC604F	152.4	20.6	50.8	65	30	38.1	6.4	14.3	68.7	8.3	159	16,208 (35,658)



## S type

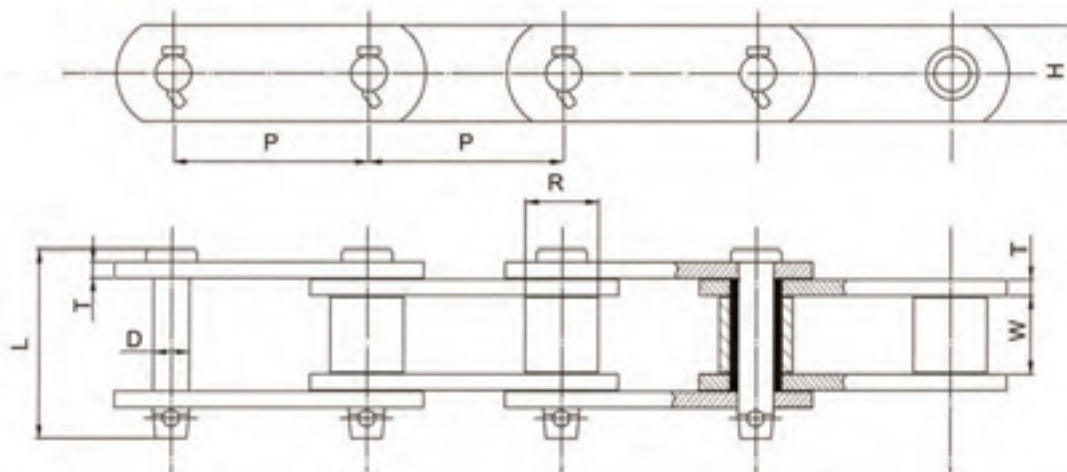

Chain No.	Pitch P	Roller		Inner Width W	Link Plate		Pin		Approx. Weight kg/m	Minimum Break Load	
		Contact E	Dia. R		Height H	Thick T	Dia. D	Length L		kN	kg (lb)
FC9503S	76.7	29.8	29	31	38.1	6.4	14.1	74.6	10.7	155	15,800 (34,760)
FC05100S	100	21	22.2	22	32	4.5	11.3	53.2	3.76	75	7,645(16,820)
FC6205S	152.4	36.3	34.9	37.1	44.5	8	15.9	85	9.15	186	18,960 (41,712)

## SA2

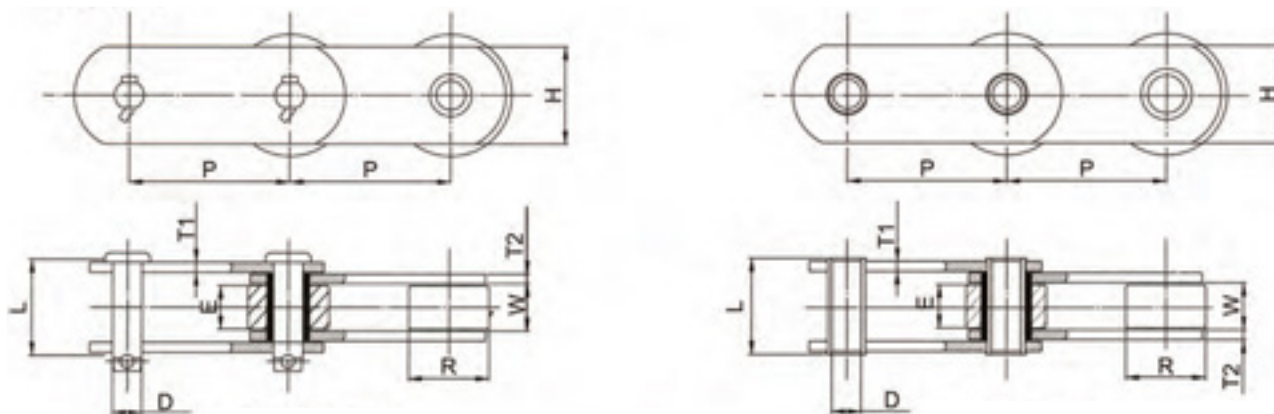

Solid Pin Type

Hollow Pin Type

Chain No.	Type	Pitch P	Roller		Inner Width W	Link Plate		Pin		Approx. Weight kg/m	Minimum Break Load	
			Contact E	Dia. R		Height H	Thick T1/T2	Dia. D	Length L		kN	kg (lb)
4SP21T	Rivet	101.4	29.8	47.6	19.1	38.1	5.1/5.1	19:1	53.2	6.99	95	9,684 (21,305)
6S960T	T pin	152.4	21	66.7	25.4	50.8	8.0/9.0	26.9	83.8	14.16	267	27,217 (59,878)
FC5289	T pin	152.4	36.3	66.8	25	50.8	6.4/6.4	22.1	67.6	11.4	223	22,732 (50,010)

Chain No.	Type	Pitch P	Roller		Inner Width W	Link Plate		Pin		Approx. Weight kg/m	Minimum Break Load	
			Contact E	Dia. R		Height H	Thick T1/T2	Dia. D	Length L		kN	kg (lb)
4HP21T	Rivet	101.4	18.8	47.6	19.1	39.4	5.1/5.1	19:1	53.2	6.99	95	9,684 (21,305)
6HP40T	Rivet	152.4	24.6	66.7	25.4	50.8	6.4/7.8	26.9	83.8	14.16	267	27,217 (59,878)

Every effort has been taken to ensure that the data listed in this catalogue is correct. TransDrive will not accept liability for any damage or loss caused as a result of the data in this catalogue.

## K1

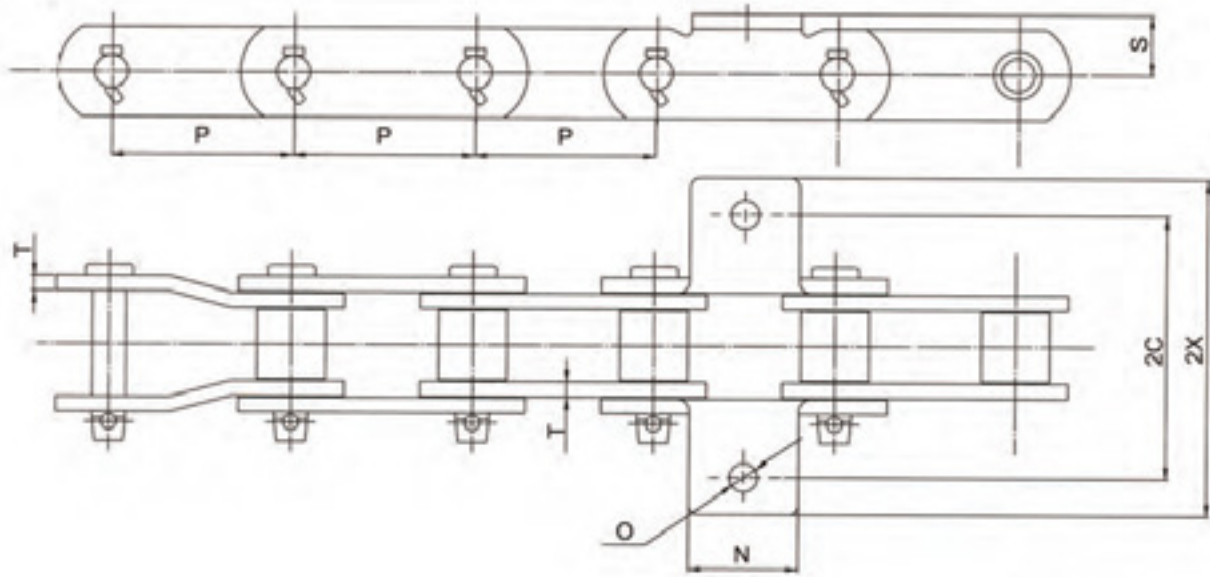

Chain No.	P mm	2C mm	2X mm	N mm	O mm	S mm	T mm
FC9503S	76.7	111.1	143	46.5	12	25.4	6.4

## A2

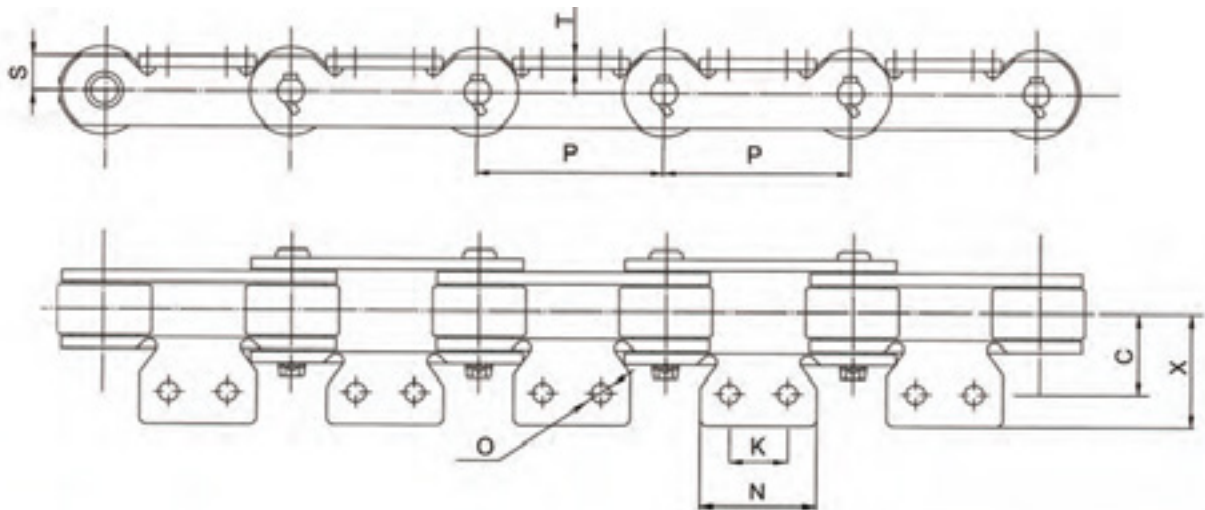

Chain No.	P mm	C mm	X mm	K mm	N mm	O mm	S mm	T mm
FC90R	101.6	44.5	61.5	31.8	63.5	11	16	4.5
FC94R	101.6	44.5	62	31.8	63.5	10.7	19.1	6.4
FC604F	152.4	50.8	50.8	50.8	90	12	19.1	6.4

# Palm Oil Conveyor Chain

## K2

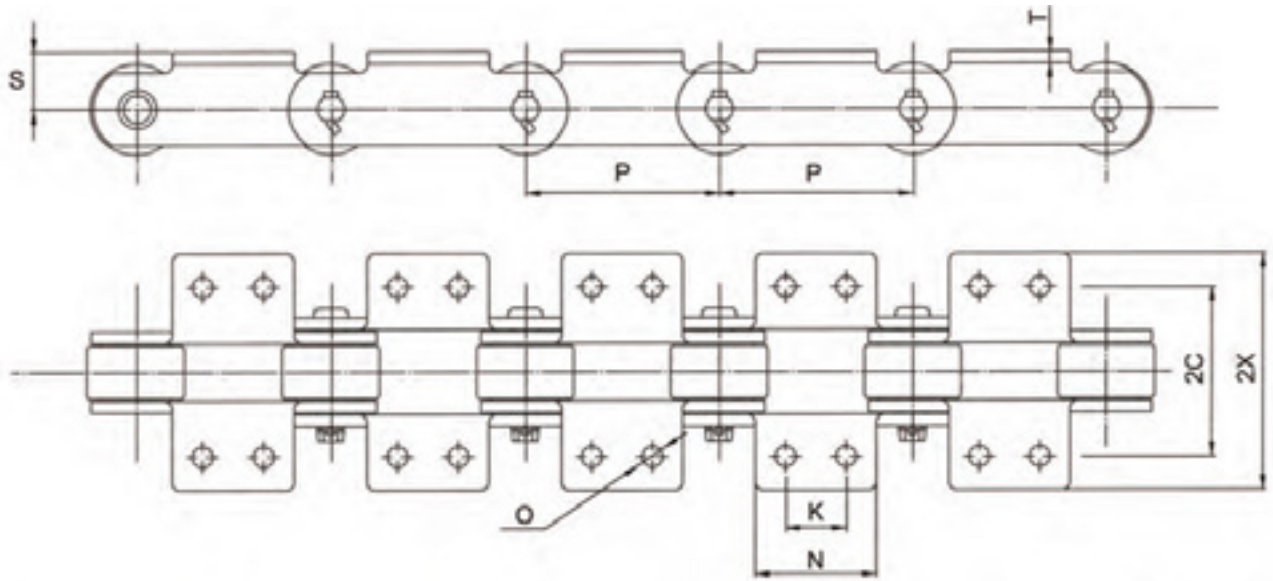

Chain No.	P mm	2C mm	2X mm	K mm	N mm	O mm	S mm	T mm
FC90R	101.6	89	123	31.8	63.5	11	31.8	4.5
FC94R	101.6	89	124	31.8	63.5	10.7	31.8	6.4

## SA2

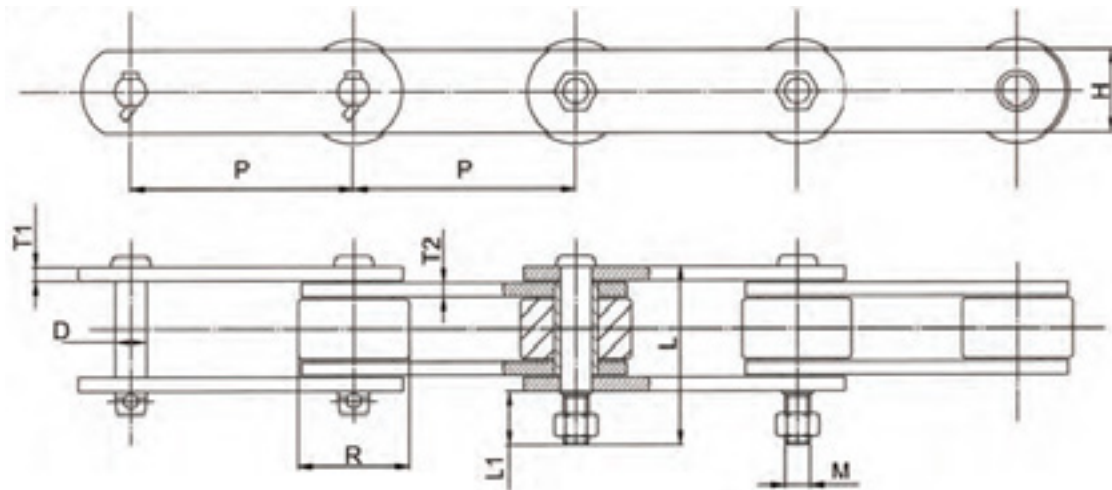

Chain No.	Pitch P mm	Roller R mm	Link Plate		Pin Dia. D mm	Pin End M mm	Extended Pin	
			H mm	T1/T2 mm			L1 mm	L mm
FC5289	152.4	66.8	50.8	6.4/6.4	22.1	M20	40	96.8
6SP60T	152.4	66.7	50.8	8.0/9.0	26.9	M24	45	114.3

## T-type

← Direction of travel

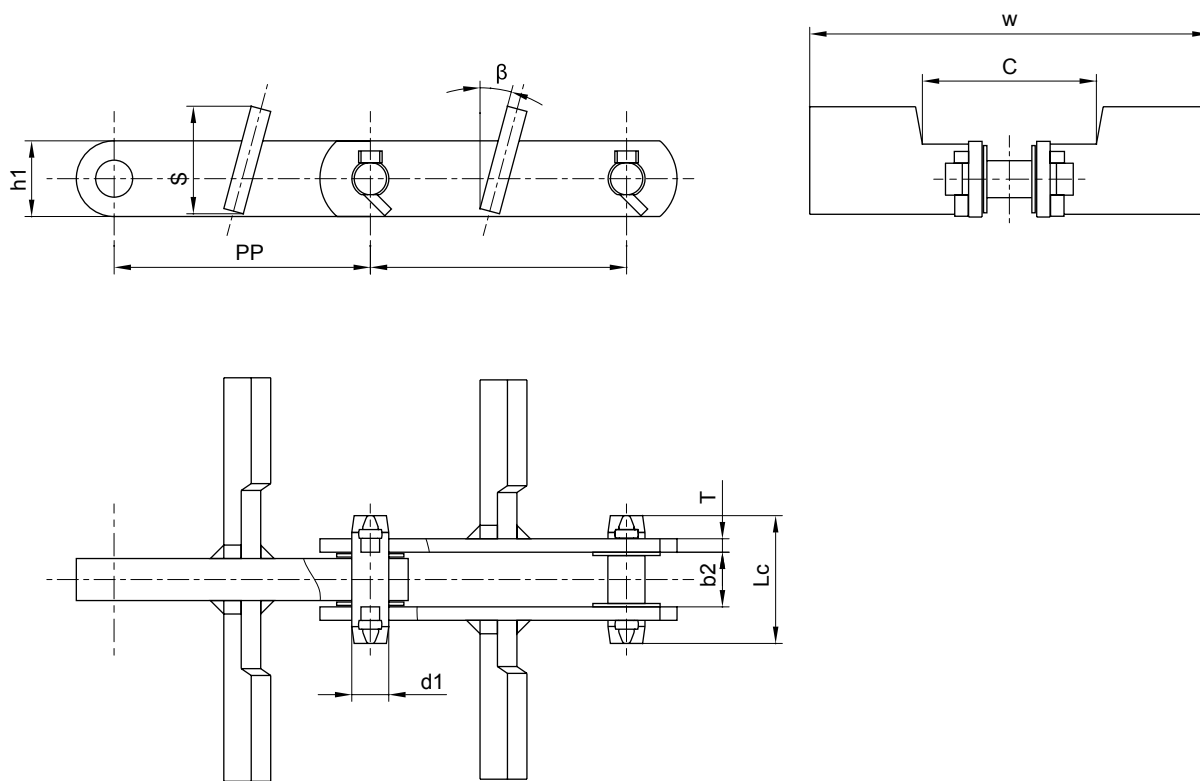

Chain No. Metric	Pitch P mm	Width Between Inner Plates b2 mm	Pin Diameter d1 mm	Pin Length Lc mm	Plate Depth h1 mm	Plate Thickness T mm	Attachment Dimensions				Ultimate Tensile Strength Q kN	Weight Per Metre q kg/m
							S mm	W mm	C mm	β mm		
P152F45	152.4	32.5	22.0	76.0	45.0	8.0	64.0	326	104	15°	260	20.40
P152F42A	152.4	32.5	22.0	76.0	45.0	8.0	83.0	286	106	15°	260	20.80
P152F45B	152.4	32.5	22.0	76.0	45.0	8.0	64.0	276	106	15°	260	18.00
P152F45C	152.4	32.5	22.0	76.0	45.0	8.0	64.0	220	106	15°	260	16.50
P152F47	152.4	34.0	22.0	85.0	45.0	12.0	81.0	400	106	15°	400	30.90
P150F17A	150.0	25.0	18.5	67.3	38.1	10.0	115.0	180	112	15°	150	14.50
P200F29	200.0	40.5	35.0	104.0	80.0	13.0	168.0	420	112	15°	530	50.60
P200F29A	200.0	40.5	35.0	104.0	80.0	13.0	148.0	430	112	15°	530	53.90
P200F35	200.0	33.0	26.5	77.0	50.0	10.0	145.5	430	210	15°	400	28.93

# Sharp Top Chain

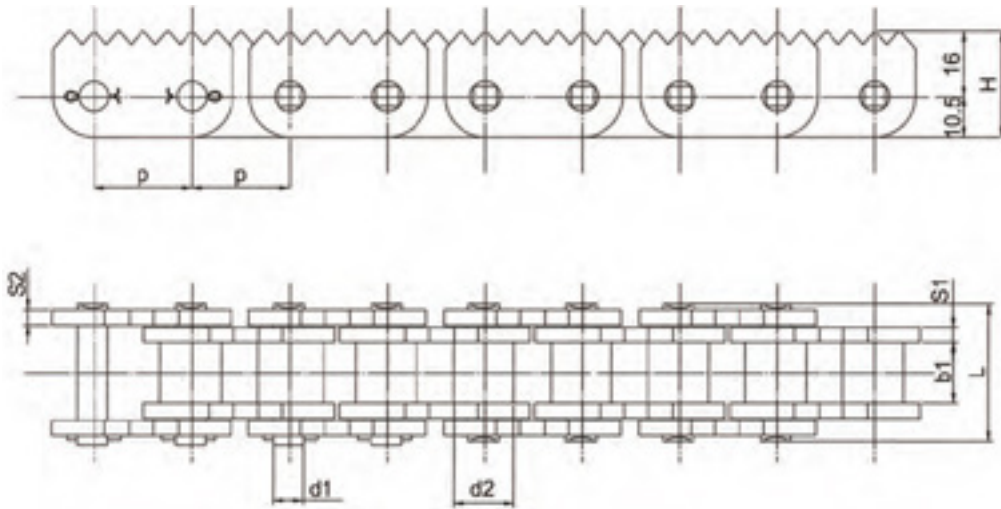

Chain Type	P mm	b1 mm	d2 mm	d1 mm	L mm	S1/S2 mm	H mm	Tensile Strength kN	Weight Per Metre kg/m
16B-1-1185	25.40	17.02	15.88	8.28	36.0	4.2/3.1	26.5	60	3.00
16B-2-1186	25.40	17.02	15.88	8.28	68.0	4.2/3.1	26.5	106	6.00
16B-3-1186	25.40	17.02	15.88	8.28	100.0	4.2/3.1	26.5	160	9.00

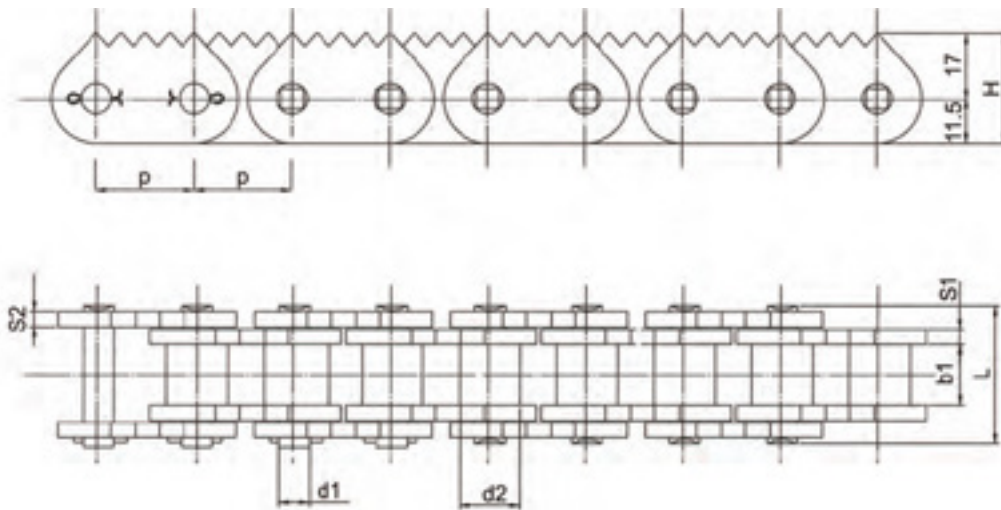

Chain Type	P mm	b1 mm	d2 mm	d1 mm	L mm	S1/S2 mm	H mm	Tensile Strength kN	Weight Per Metre kg/m
8CH-1230	25.40	15.88	15.88	7.93	33.0	32	28.5	60	1.85
80-2-1230	25.40	15.88	15.88	7.93	61.8	32	28.5	100	3.70
80-3-1230	25.40	15.88	15.88	7.93	91.2	32	28.5	160	5.60



# Sharp Top Chain

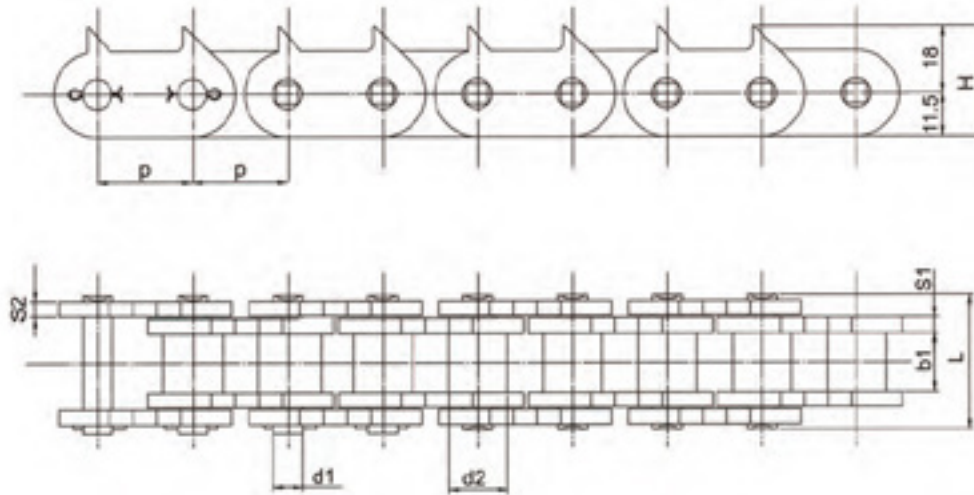

Chain Type	P mm	b1 mm	d2 mm	d1 mm	L mm	S1/S2 mm	H mm	Tensile Strength kN	Weight Per Metre kg/m
80-1-1274	25.40	15.88	15.88	7.93	33.0	3.2	29.5	73.5	2.95
80-2-1274	25.40	15.88	15.88	7.93	61.8	3.2	29.5	147	5.70
80-3-1274	25.40	15.88	15.88	7.93	91.2	3.2	29.5	220.5	8.50

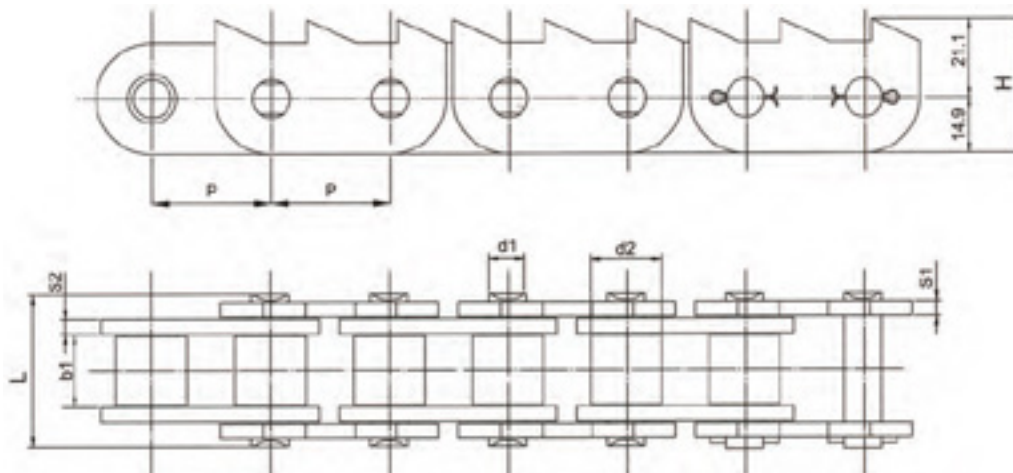

Chain Type	P mm	b1 mm	d2 mm	d1 mm	L mm	S1/S2 mm	H mm	Tensile Strength kN	Weight Per Metre kg/m
100-1-1200	31.75	19.05	19.05	9.53	34.9	4.0	36.0	112700	4.50
100-2-1200	31.75	19.05	19.05	9.53	75.0	4.0	36.0	225400	9.50
100-3-1200	31.75	19.05	19.05	9.53	111.0	4.0	36.0	338100	14.00

# Sharp Top Chain

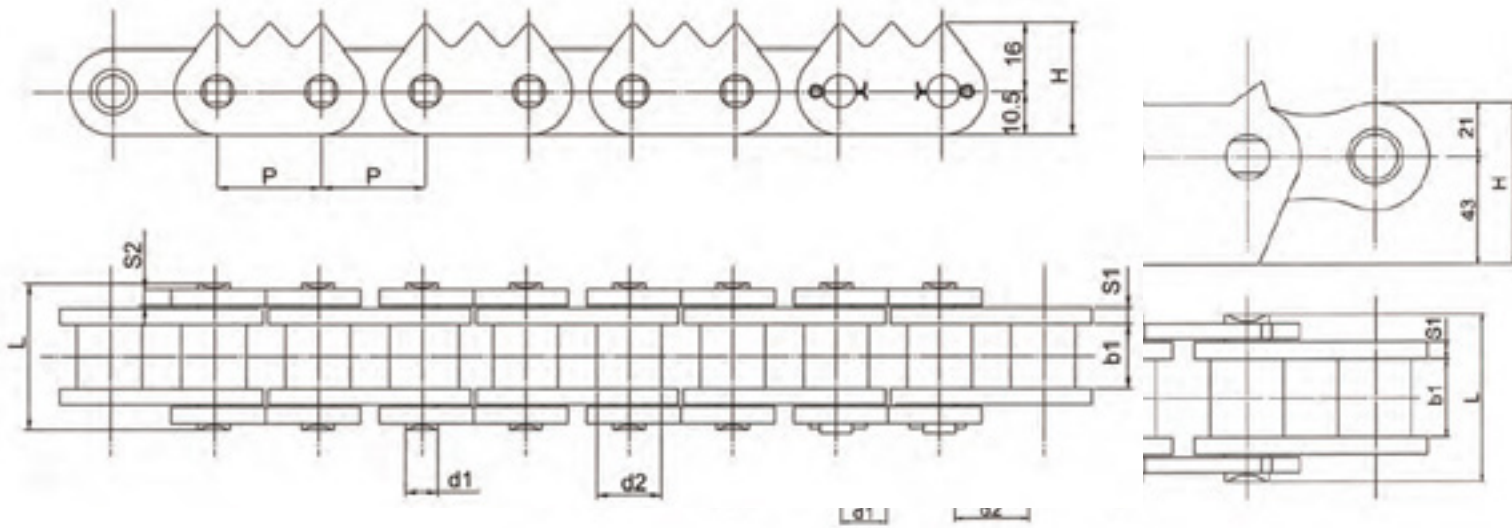

Chain Type	P mm	b1 mm	d2 mm	d1 mm	L mm	S1/S2 mm	H mm	Tensile Strength kN	Weight Per Metre kg/m
16B-1-1170	25.40	17.02	15.88	8.28	36.0	4.2/3.1	26.5	60	2.90
16B-2-1170	25.40	17.02	15.88	8.28	68.0	4.2/3.1	26.5	106	5.80
16B-3-1170	25.40	17.02	15.88	8.28	100.0	4.2/3.1	26.5	166	8.40

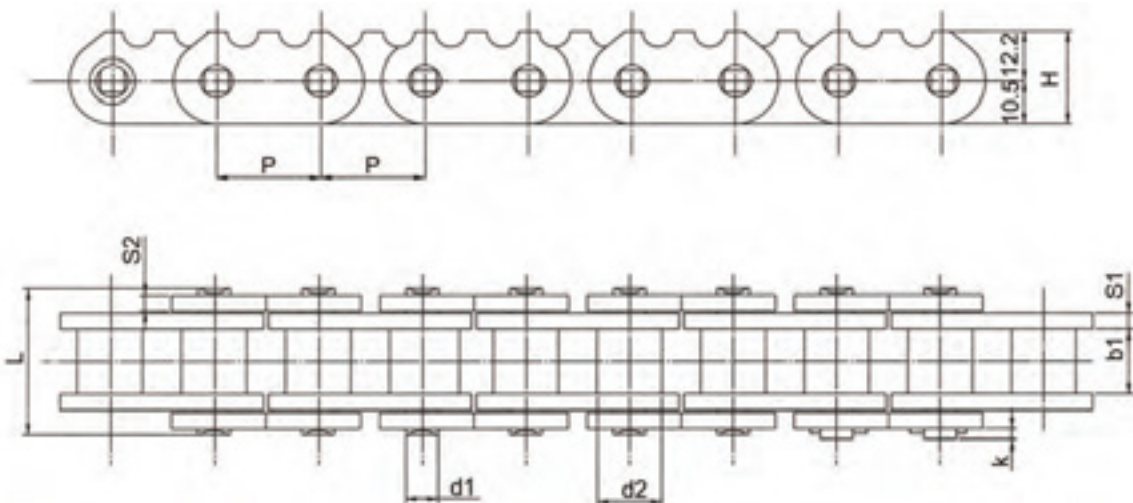

Chain Type	P mm	b1 mm	d2 mm	d1 mm	L mm	K mm	S1/S2 mm	H mm	Tensile Strength kN	Weight Per Metre kg/m
16B-1-1180	25.40	17.02	15.88	8.28	36.0	3.6	4.2/3.1	22.5	60	2.90
16B-2-1180	25.40	17.02	15.88	8.28	68.0	3.6	4.2/3.1	22.5	106	5.80
16B-3-1180	25.40	17.02	15.88	8.28	100.0	3.6	4.2/3.1	22.5	166	8.40

# Sharp Top Chain BS

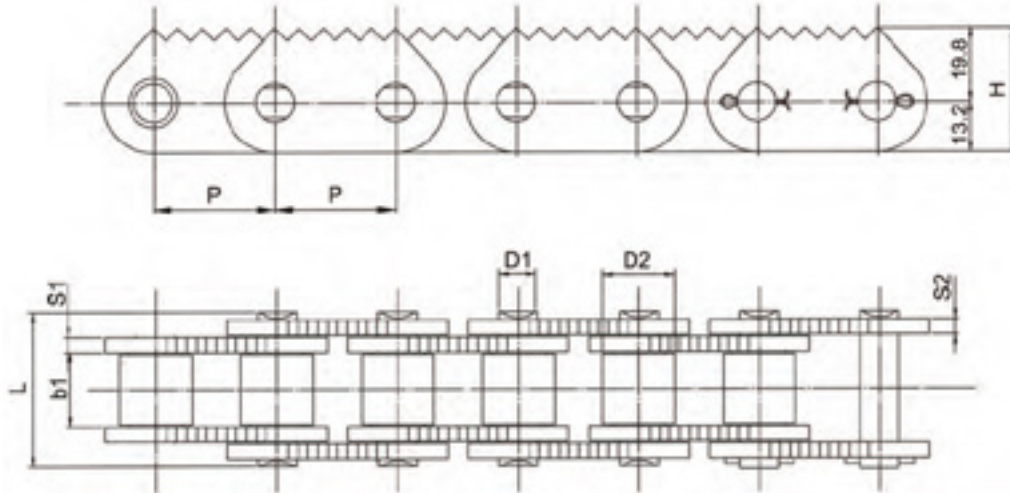

Chain Type	P mm	b1 mm	d2 mm	d1 mm	L mm	S1/S2 mm	H mm	Tensile Strength kN	Weight Per Metre kg/m
20B-1-1310	31.75	19.56	19.05	10.19	41.0	4.5/3.5	33.0	95	5.0

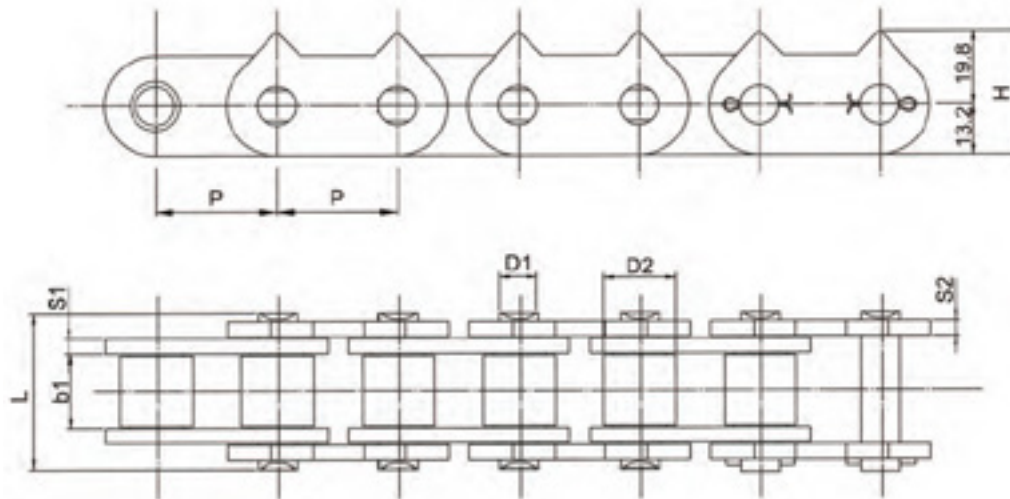

Chain Type	P mm	b1 mm	d2 mm	d1 mm	L mm	S1/S2 mm	H mm	Tensile Strength kN	Weight Per Metre kg/m
20B-1-1350	31.75	19.56	19.05	10.19	41.0	4.5/3.5	33.0	95	4.6
20B-2-1350	31.75	19.56	19.05	10.19	77.2	4.5/3.5	33.0	170	9.1



# Sharp Top Chain BS

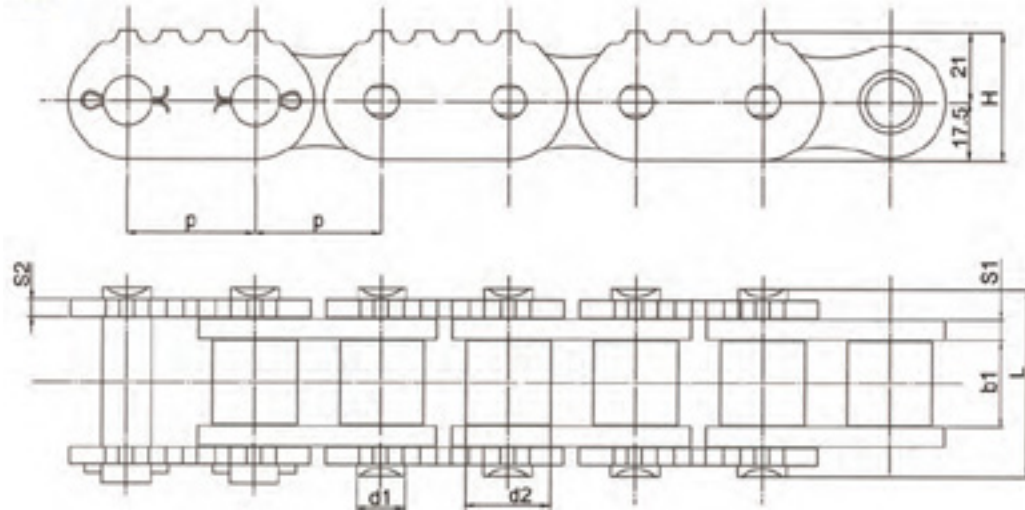

Chain Type	P mm	b1 mm	d2 mm	d1 mm	L mm	S1/S2 mm	H mm	Tensile Strength kN	Weight Per Metre kg/m
24B-1-1794	38.10	25.40	25.40	14.63	54.0	6.0/4.8	38.5	160	8.6
24B-2-1794	38.10	25.40	25.40	14.63	101.0	6.0/4.8	38.5	280	17.2

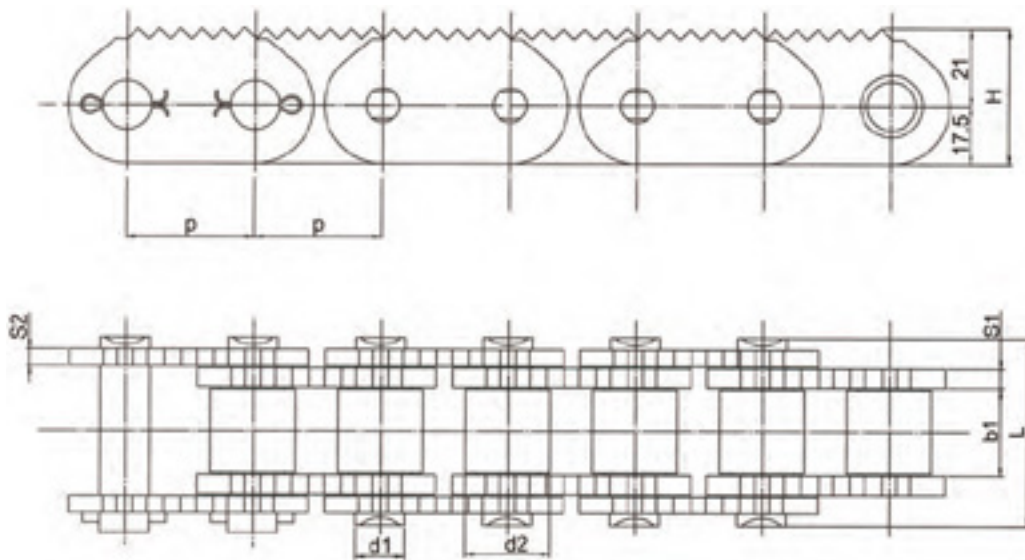

Chain Type	P mm	b1 mm	d2 mm	d1 mm	L mm	S1/S2 mm	H mm	Tensile Strength kN	Weight Per Metre kg/m
24B-1-1820	38.10	25.40	25.40	14.63	54.0	6.0/4.8	38.5	160	9.1
24B-2-1820	38.10	25.40	25.40	14.63	101.0	6.0/4.8	38.5	280	18.0

# Sharp Top Chain BS

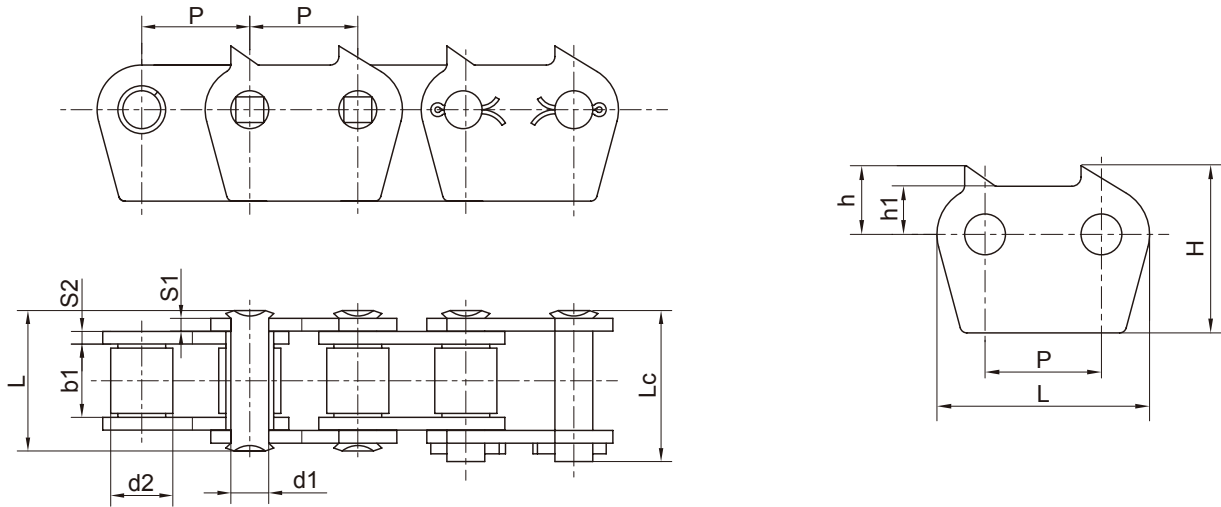

Chain Type	P mm	b1 mm	d2 mm	d1 mm	L mm	Lc mm	S1 mm	S2 mm	Tensile Strength kN	Weight Per Metre kg/m	Sharp Top Chain Profile	P mm	L mm	h1 mm	h mm	H mm
32B-1-1874	50.8	31.0	29.21	17.81	66	71	7.0	6.0	250	12.0	-	50.8	92.8	21	30	73

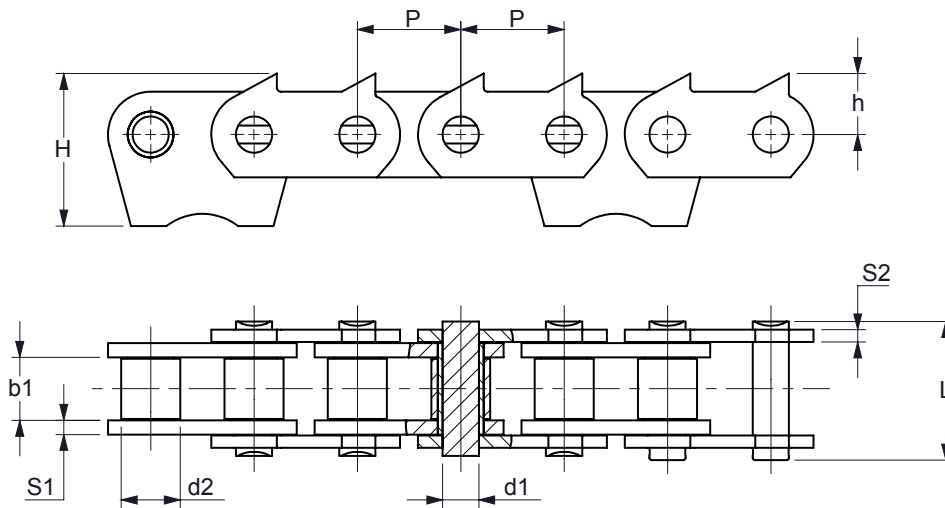

Chain Type	P mm	b1 mm	d2 mm	d1 mm	L mm	S1 mm	S2 mm	H mm	h mm	Tensile Strength kN	Weight Per Metre kg/m
32B-1-1890	50.8	31.0	29.21	17.81	66	7.0	6.0	75.0	30.0	250	12.5

### Cane Carrier

TransDrive Sugar Mill Chains are engineered for superior performance and reliability in sugar production. Designed to withstand the toughest conditions, our chains ensure efficient transport of raw materials, maximising productivity.

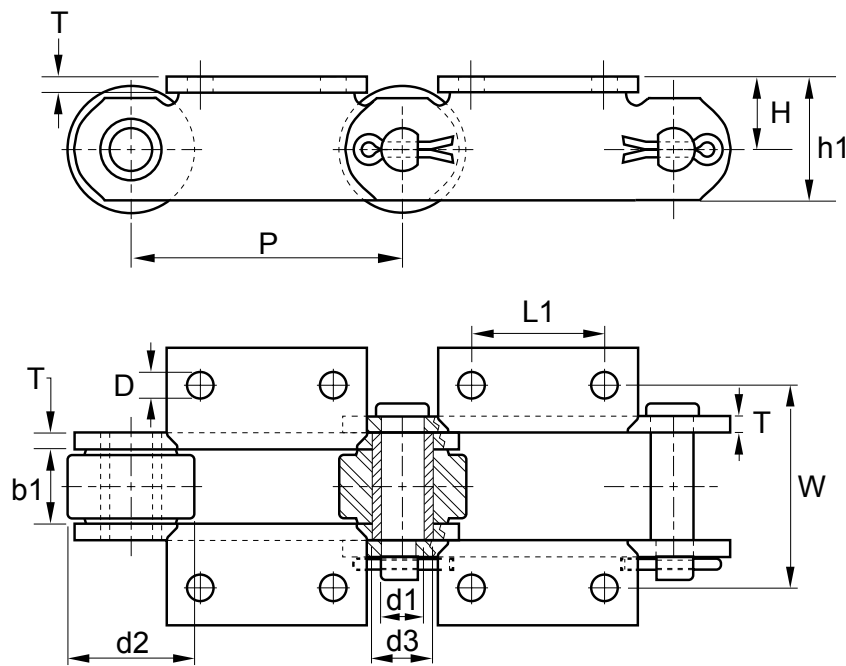

Chain No.	Pitch P mm	Allowable Chain Pull lb	Breaking Load		Width Between Inner Plates b1 min mm	Roller Diameter d2 max mm	Bush Diameter d1 max mm	Connecting Pin Diameter L1 max mm	Plate Thickness T1/T2 max mm	Attachment Hole Diameter D max mm	Hole Centres Q min kN	Hole Transverse Centres Q min kN	Platform Height H kN
			lb	kgf									
9060	152.4	6,350	60,000	27,200	38.1	69.85	12.7	19.05	9.53	13.87	76.2	111.13	41.4
SS996	152.4	6,350	70,000	31,750	38.1	69.85	12.7	19.05	9.53	13.87	76.2	111.13	41.4
9061	152.4	6,350	85,000	38,600	38.1	69.85	12.7	19.05	9.53	13.87	76.2	111.13	41.4
1796	152.4	7,500	100,000	45,400	38.1	69.85	12.7	22.23	9.53	13.87	76.2	111.13	41.4
SS2198	152.4	7,500	100,000	45,400	38.1	69.85	12.7	22.23	12.7	13.87	76.2	111.13	41.4
9063	152.4	8,300	140,000	63,500	38.1	76.20	12.7	23.83	10.31	13.87	76.2	111.13	41.4

### Intermediate carrier and Bagasse

TransDrive Sugar Mill Chains are engineered for superior performance and reliability in sugar production. All are manufactured from high-quality steel and heat treated to obtain optimum characteristics of strength and wear resistance. The K2 / AS2 swivel attachments allows for self-alignment of the strands during operation compensating for any mismatch.

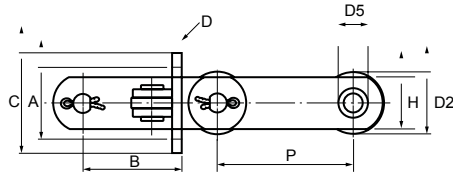

**Style A**

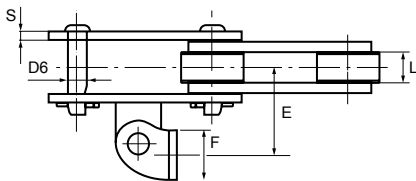

**Style B**

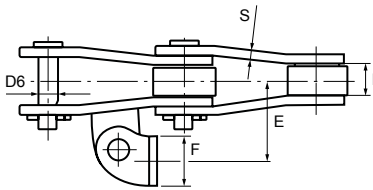

**Style C**

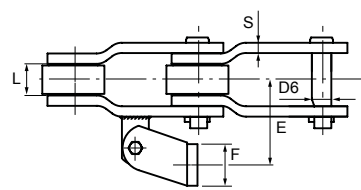

Chain Number	Style	Units	Pitch	Rollers		Bushing	Pins	Between Side-bars	Sidebar		AS2 Attachment Dimensions					Bolt Diameter	Working Load	Breaking Load	Weight
				Diameter	Diameter	Thickness			Height	A	B	C	E	F	D				
			P	D2	D5	D6	L	S	H	A	B	C	E	F	D				
0904	A/B	mm	101.6	50.8	25.4	17.53	31	7.87	44.5	82.3	79.5	107.95	77.72	45.5	9.65	2,200 kg	18,200 kg	12.10 kg/m	
		in	4	2	1	0.69	1.22	0.31	1.75	3.24	3.13	4.25	3.06	1.75	0.38	4,850 lb	40,000 lb	8.11 lb/ft	
09060	A/B	mm	152.40	69.85	28.70	19.05	38.10	9.65	50.80	82.55	111.25	114.30	88.90	50.80	12.70	2,900 kg	27,200 kg	16.70 kg/m	
		in	6.00	2.75	1.13	0.75	1.50	0.38	2.00	3.25	4.38	4.50	3.50	2.00	0.50	6,350 lb	60,000 lb	11.20 lb/ft	
2184	B	mm	152.40	76.20	31.75	22.35	35.05	9.65	50.80	88.90	142.75	127.00	91.95	50.80	12.70	3,000 kg	36,600 kg	18.50 kg/m	
		in	6.00	3.00	1.25	0.88	1.38	0.38	2.00	3.50	5.62	5.00	3.62	2.00	0.50	6,500 lb	85,000 lb	12.41 lb/ft	
09061	A/B	mm	152.40	69.85	28.70	19.10	38.10	9.65	57.50	82.55	111.25	114.30	88.90	50.80	12.70	2,900 kg	38,600 kg	18.50 kg/m	
		in	6.00	2.75	1.13	0.75	1.50	0.38	2.25	3.25	4.38	4.50	3.50	2.00	0.50	6,350 lb	85,000 lb	12.41 lb/ft	
9184	C	mm	152.40	76.20	31.80	23.90	38.90	12.70	63.50	88.90	142.75	127.00	104.60	50.80	12.70	3,800 kg	45,400 kg	26.20 kg/m	
		in	6.00	3.00	1.25	0.94	1.53	0.50	2.50	3.50	5.62	5.00	4.12	2.00	0.50	8,300 lb	100,000 lb	17.57 lb/ft	
9185	C	mm	152.40	88.90	31.80	23.90	38.90	12.70	63.50	88.90	142.75	127.00	104.60	50.80	12.70	3,800 kg	45,400 kg	30.70 kg/m	
		in	6.00	3.50	1.25	0.94	1.53	0.50	2.50	3.50	5.62	5.00	4.12	2.00	0.50	8,300 lb	100,000 lb	20.59 lb/ft	
1796	A/B	mm	152.40	69.85	31.80	22.35	38.10	9.65	57.15	82.55	111.25	114.30	88.90	50.80	12.70	3,800 kg	45,400 kg	25.18 kg/m	
		in	6.00	2.75	1.25	0.88	1.50	0.38	2.25	3.25	4.38	4.50	3.50	2.00	0.50	8,300 lb	100,000 lb	16.88 lb/ft	
09063	A/B	mm	152.40	76.20	31.80	23.89	38.10	10.40	60.45	88.90	142.75	127.00	104.65	50.80	12.70	3,800 kg	63,500 kg	28.95 kg/m	
		in	6.00	3.00	1.25	0.94	1.50	0.41	2.38	3.50	5.62	5.00	4.12	2.00	0.50	8,300 lb	140,000 lb	19.42 lb/ft	
2198	A/B	mm	152.40	69.85	31.80	22.35	38.10	12.70	57.15	88.90	142.75	127.00	98.55	50.80	12.70	3,800 kg	45,400 kg	26.50 kg/m	
		in	6.00	2.75	1.25	0.88	1.50	0.50	2.25	3.50	5.62	5.00	3.88	2.00	0.50	8,300 lb	100,000 lb	17.77 lb/ft	
2113	B	mm	102.62	50.80	25.40	17.53	33.27	7.87	50.80	69.85	141.22	120.65	85.85	50.80	12.70	2,100 kg	11,800 kg	12.70 kg/m	
		in	4.04	2.00	1.00	0.69	1.31	0.31	2.00	2.75	5.56	4.75	3.38	2.00	0.50	4,685 lb	26,000 lb	8.52 lb/ft	
9065	A	mm	152.40	76.20	38.10	26.92	38.10	12.70	60.45	84.07	111.25	114.30	91.69	50.80	12.70	4,200 kg	72,700 kg	29.00 kg/m	
		in	6.00	3.00	1.50	1.06	1.50	0.50	2.38	3.31	4.38	4.50	3.61	2.00	0.50	9,275 lb	160,000 lb	19.45 lb/ft	
2178A	B	mm	152.40	69.85	31.80	22.23	38.10	9.65	57.15	88.90	142.75	127.00	104.65	50.80	12.70	3,800 kg	45,400 kg	19.20 kg/m	
		in	6.00	2.75	1.25	0.88	1.50	0.38	2.25	3.50	5.62	5.00	4.12	2.00	0.50	8,300 lb	100,000 lb	12.88 lb/ft	

## Diffuser Chain

Our diffuser chains are specifically treated to withstand the rigorous washing and straining processes involved in the sugar industry, ensuring maximum corrosion resistance.

Designed to run in matched pairs, our chains feature a multi-level slat system that efficiently moves and separates juice in the diffuser. The use of solid inner plate links and stainless steel pins minimises corrosion and enhances durability.



Available in various sizes to meet your mill's specific requirements, we also offer Roller Type Diffuser Chains.

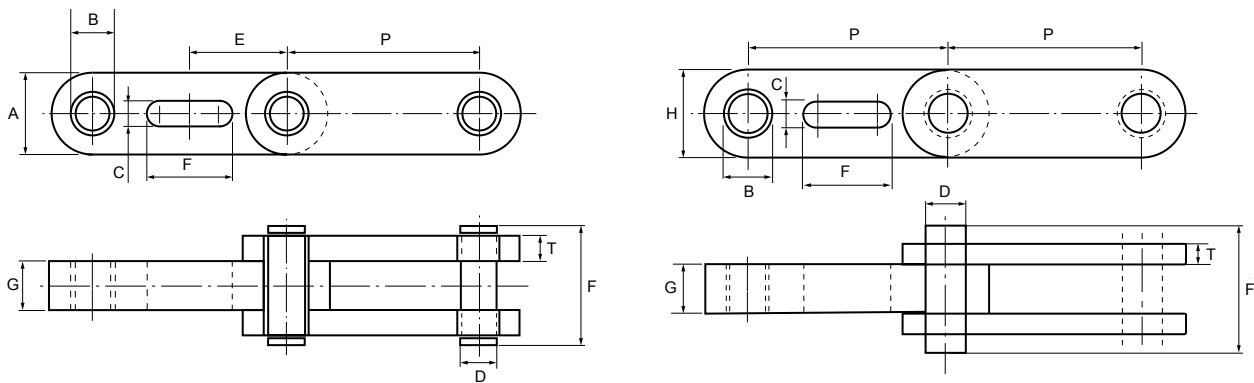

Chain Number	Units	Pitch P	Bushing Diameter D5	Pin Diameter D6	Oven Pin F	Between Sidebars L	Sidebars Thickness S	Sidebars Height A	F	B	C	Breaking Strength
BL4039/T1	mm	250	56	47	150	62	20	80	111	60	35	175,000kg
	inches	9.84	2.2	1.85	5.9	2.44	0.75	3.15	4.37	2.36	1.38	385,000lb
BL4039/T2	mm	250	51	42	100	43	12	80	111	40	35	64,240kg
	inches	9.84	2	1.65	3.94	1.69	0.5	3.15	4.37	1.57	1.38	141,323lb
BL4600	mm	250	58	49	30	66	47	110	111	60	35	224,300kg
	inches	9.84	2.28	1.93	1.18	2.6	1.85	4.33	4.37	2.36	1.38	493,460lb
BL4961	mm	300	71.9	60	157.5	68	31	130	125	60	25	345,000kg
	inches	11.8	2.83	2.36	6.2	2.68	1.22	5.12	4.92	2.36	1	759,000lb
BL5036	mm	443.6	127.8	50.8	181	74.6	37.3	127.8	101.6	123.8	31.8	338,000kg
	inches	17.5	5	2	7.13	2.94	1.47	5	4	4.87	1.25	743,600lb

Chain Number	Pitch P	Allowable Load	U.T.S.	Pin Diameter D	Sidebar Depth	Max Gearing G	Bush Diameter B	C	E	F	Bolt Diameter H	T	W	X
E30200	200mm	2,850	90,000	0.75	1.75	1	1.12	15mm	100mm	65mm	20mm	0.31	2	2.88

Chain Number	Pitch P	Allowable Load	U.T.S.	Pin Diameter D	Sidebar Depth	Max Gearing G	Bush Diameter B	C	F	T
BL09060	6	4,400	60,000	0.75	2	40mm	1.12	28mm	75mm	0.38
BL09063	6	7,200	140,000	0.94	2.38	55mm	1.25	29mm	73.5mm	0.41

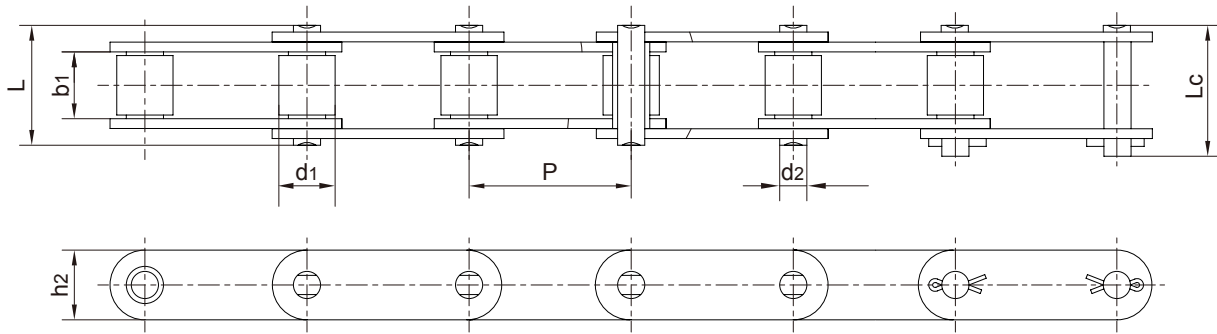

Chain No.	Pitch P mm	Roller Diameter d2 max mm	Width Between Inner Plates b1 min mm	Pin Diameter d1 max mm	Pin Length		Inner Plate Depth H max mm	Plate Thickness T1/T2 max mm	Ultimate Tensile Strength Q min kN	Average Tensile Strength Q0 kN	Ultimate Tensile Strength q kg/m
					L max mm	Lc max mm					
81X	66.27	23.00	27.00	11.10	49.0	53.5	28.50	4.00	106.7	128.9	3.78
81XH	66.27	23.00	27.78	11.10	60.7	65.1	31.35	7.94/5.55	151.9	175.7	5.88
81XHE	66.27	22.20	27.00	11.10	59.5	63.0	28.50	6.30	83.3	89.1	5.09
81XF14	66.27	23.00	27.00	11.10	50.8	53.8	28.70	4.00	85.5	91.4	3.78
81XHH	66.27	23.00	27.78	11.10	65.6	70.0	31.35	7.94	191.1	212.6	6.70
81XHS	66.27	23.00	27.00	11.10	63.6	68.0	31.80	7.60	152.0	177.2	6.55

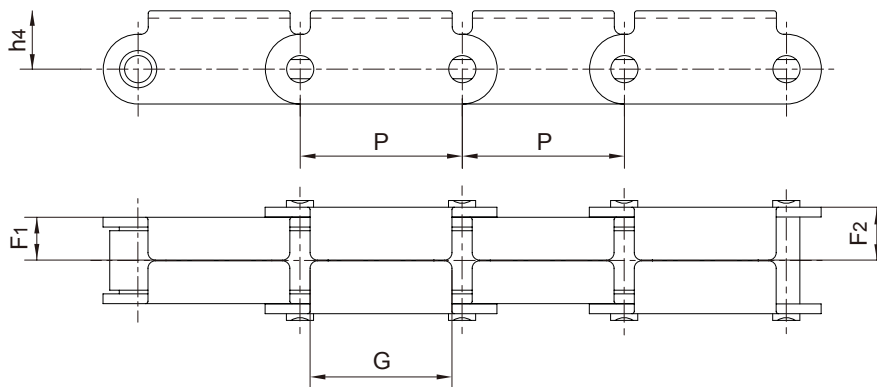

Chain No.	P mm	F1 mm	F2 mm	G mm	h4 mm
81XF1(RT)	66.27	17.5	21.8	58.0	23.85

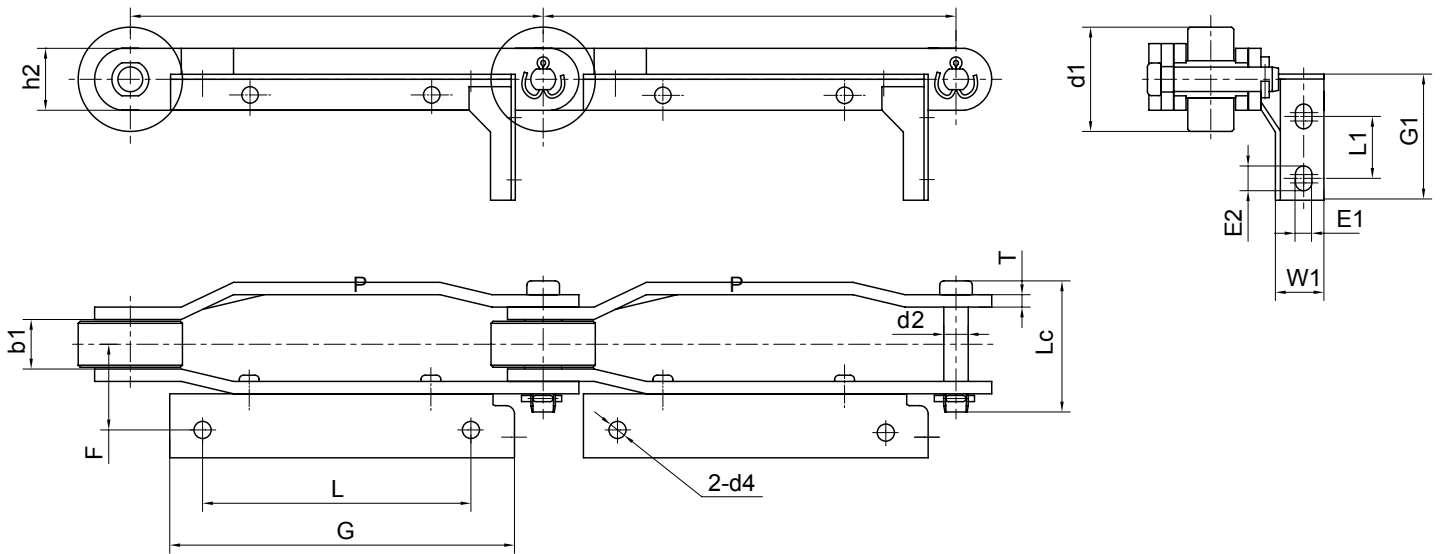

Chain No.	Pitch P mm	Roller Diameter d1 max mm	Width Between Inner Plates b1 min mm	Pin Diameter d2 max mm	Plate Thickness T max mm	Inner Plate Depth h2 max mm	Pin Length Lc max mm	Attachment Dimensions								Ultimate Tensile Strength min kN	
								G mm	L mm	F mm	G1 mm	L1 mm	W1 mm	E1 mm	E2 mm		d4 mm
P200A2	200	50.0	23	11.9	6.3	32.0	62.0	167.0	130.0	41.2	60.0	30.0	23.0	8.0	12	8.0	110.0

# Trencher Chains

## 2L

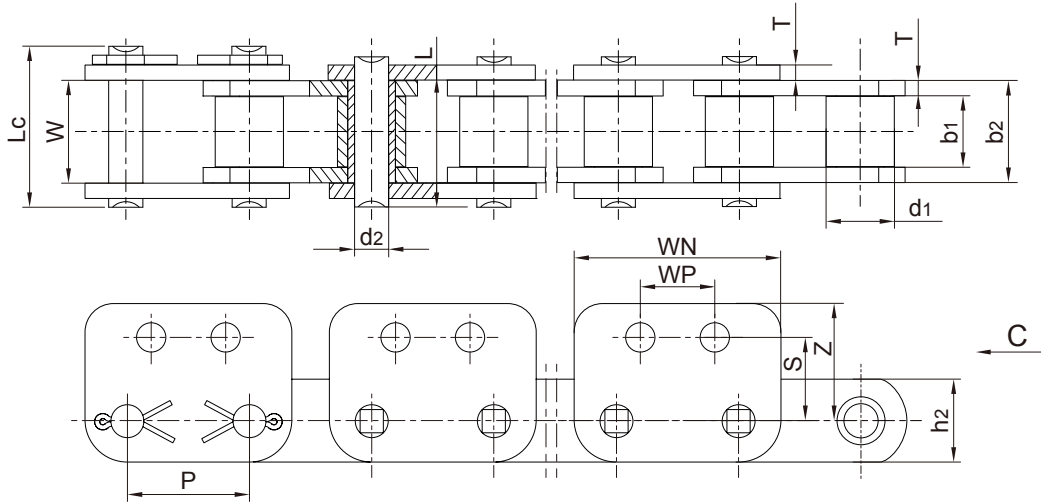

## 4L

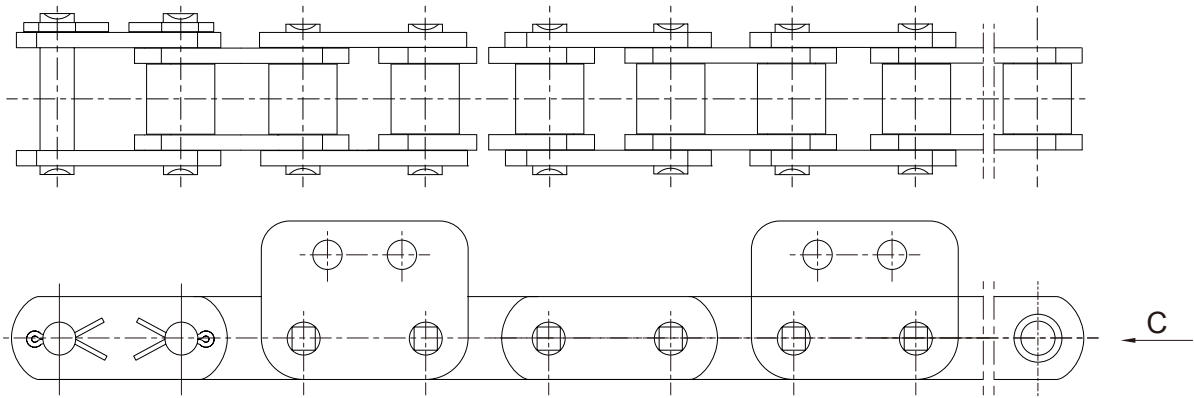

Chain No.	Pitch P	Dimensions Chart														Ultimate Tensile Strength Q0 kN	Weight Per Metre q kg/m
		d1 max	d2 min	b1 max	b2 max	W max	h2 max	L max	Lc max	T	O	WN	WP	S	Z		
4210-2L	42.01	22.23	11.1	25.5	35.3	35.4	28.6	50.25	52.85	4.8	10	70.6	46.04	28.6	39.7	102.3	6.8
4210-4L																	6.09
4210H-2L	42.01	22.23	11.1	25.5	35.3	35.4	31.6	53.4	57.5	4.8	10	70.6	46.04	30.0	41.0	102.3	6.8
4210H-4L																	6.09
5019-2L	50.8	28.58	14.27	32.05	45.15	45.25	38.1	64.8	69.5	6.45	13.5	93	50.8	38.1	56.65	134.4	13.21
5019-4L																	11.47



**T-type**

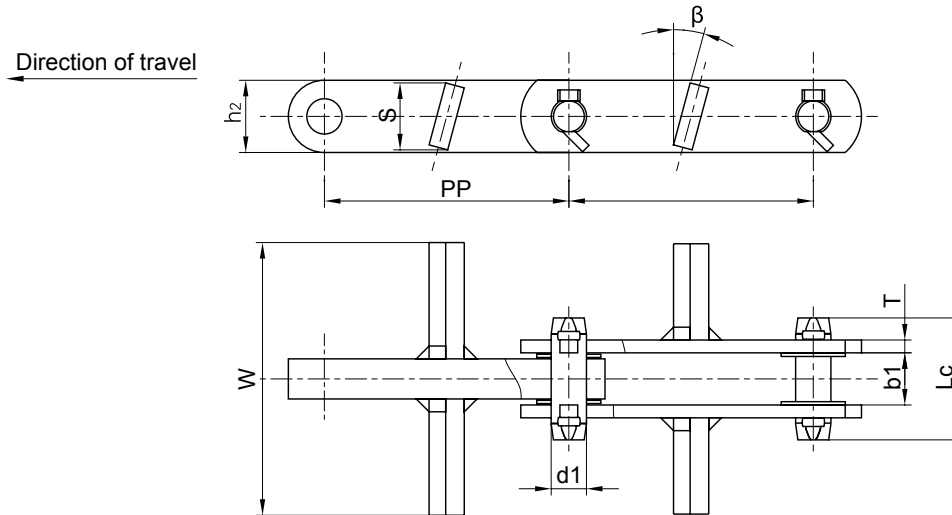

Chain No. Metric	Pitch P mm	Width Between Inner Plates b1 mm	Pin Diameter d1 mm	Pin Length Lc mm	Plate Depth h1 mm	Plate Thickness T mm	Attachment Dimensions			Ultimate Tensile Strength Q kN	Weight Per Metre q kg/m
							S mm	W mm	β mm		
P101.6F20	101.6	16.5	17.46	53.7	38.0	6.0	34.0	210.0	45°	100	7.26
P152F2	152.4	33.3	22.00	76.0	45.0	8.0	38.0	180.0	20°	260	12.10
P152F45O	152.4	32.5	22.00	76.0	45.0	8.0	42.0	170.0	15°	260	13.50
P152F45E	152.4	32.5	22.00	76.0	45.0	8.0	42.0	280.0	15°	260	16.20
P152F45F	152.4	32.5	22.00	76.0	45.0	8.0	42.0	227.0	15°	260	14.90
P152F46	152.4	40.8	25.00	86.0	50.0	9.0	49.0	290.0	15°	300	20.80
P150F17C	150.0	25.0	18.50	67.3	38.1	10.0	36.0	168.0	15°	150	10.60

**U-type**

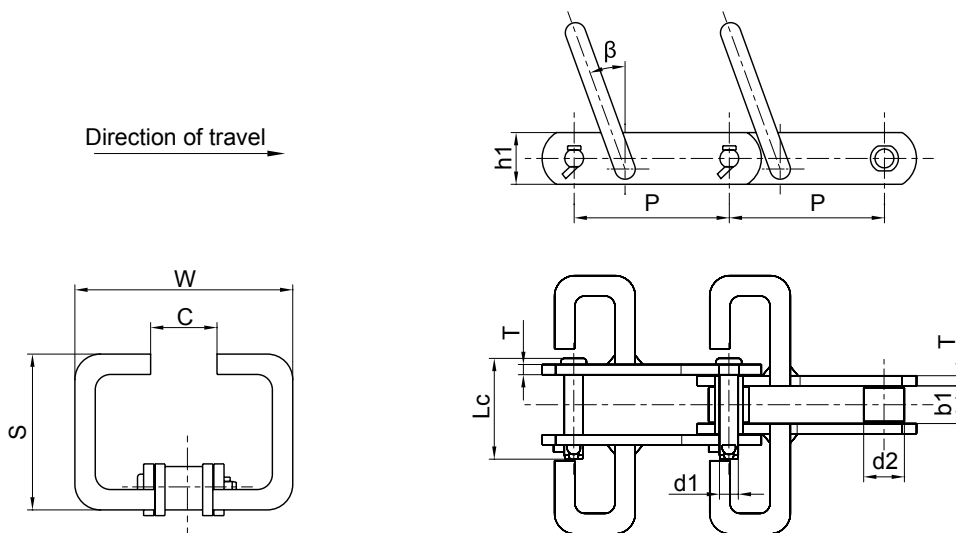

Chain No.	Pitch P mm	Roller Diameter d1 max mm	Width Between Inner Plates b1 mm	Pin Diameter d1 mm	Pin Length Lc mm	Plate Depth h1 mm	Plate Thickness T mm	Attachment Dimensions				Ultimate Tensile Strength Q kN	Weight Per Metre q kg/m
								h2 mm	W mm	C mm	β mm		
P152F51	152.4	40.0	36.0	18.5	95.5	50.8	10.0	175.0	310.0	110.0	20°	170	24.9

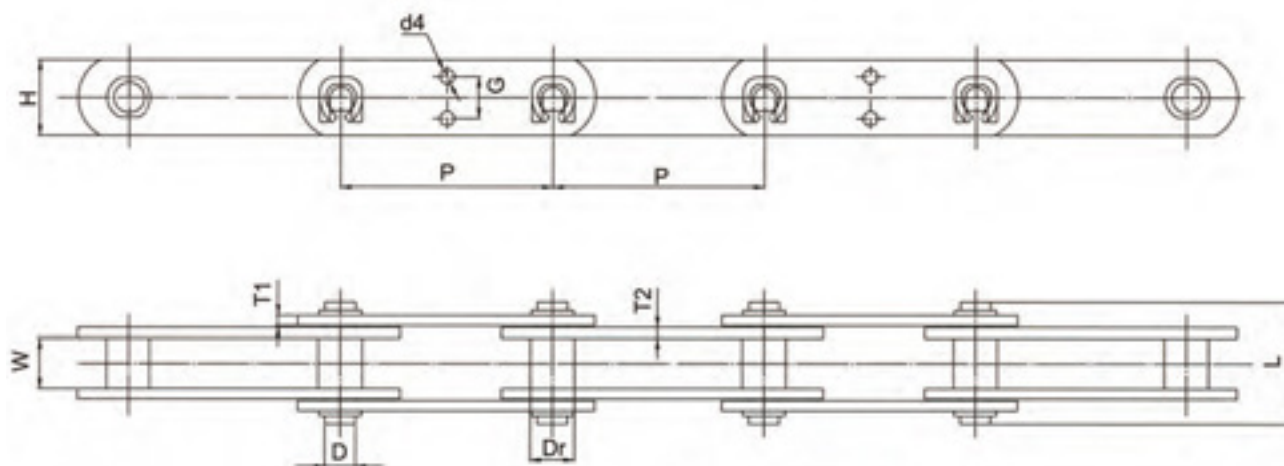

Chain No.	Pitch P mm	Bush Diameter Dr max mm	Width Between Inner Plates W min mm	Pin Diameter D max mm	Pin Length L mm	Plate Dimensions					Ultimate Tensile Strength min kN
						H max mm	T1 max mm	T2 max mm	G mm	d4 mm	
P803022	80	22.0	30.0	16.0	69.5	40.0	6.0	6.0	—	—	155.0
P803530	80	30.0	35.0	20.0	85.5	50.0	8.0	8.0	—	—	225.0
P1002520	100	20.0	25.0	14.0	63.0	35.0	5.0	5.0	—	—	140.0
P1252520	125	20.0	25.0	14.0	63.0	35.0	5.0	5.0	20.0	6.5	140.0
P1253026	125	26.0	30.0	18.0	72.2	45.0	6.0	6.0	25.0	8.5	160.0
P1253030	125	30.0	30.0	20.0	80.5	50.0	8.0	8.0	30.0	8.5	190.0
P1253022	125	22.0	30.0	16.0	69.5	40.0	6.0	6.0	25.0	8.5	155.0
P1253526	125	26.0	35.0	18.0	77.5	45.0	6.0	6.0	25.0	8.5	160.0
P1254530	125	30.0	45.0	20.0	96.0	50.0	8.0	8.0	30.0	8.5	230.0
P1503022	150	22.0	30.0	16.0	72.0	50.0	6.0	6.0	30.0	8.5	230.0
P1504530	150	30.0	45.0	20.0	96.0	50.0	8.0	8.0	—	—	230.0
P1604530	160	30.0	45.0	20.0	96.0	50.0	8.0	8.0	30.0	8.5	230.0

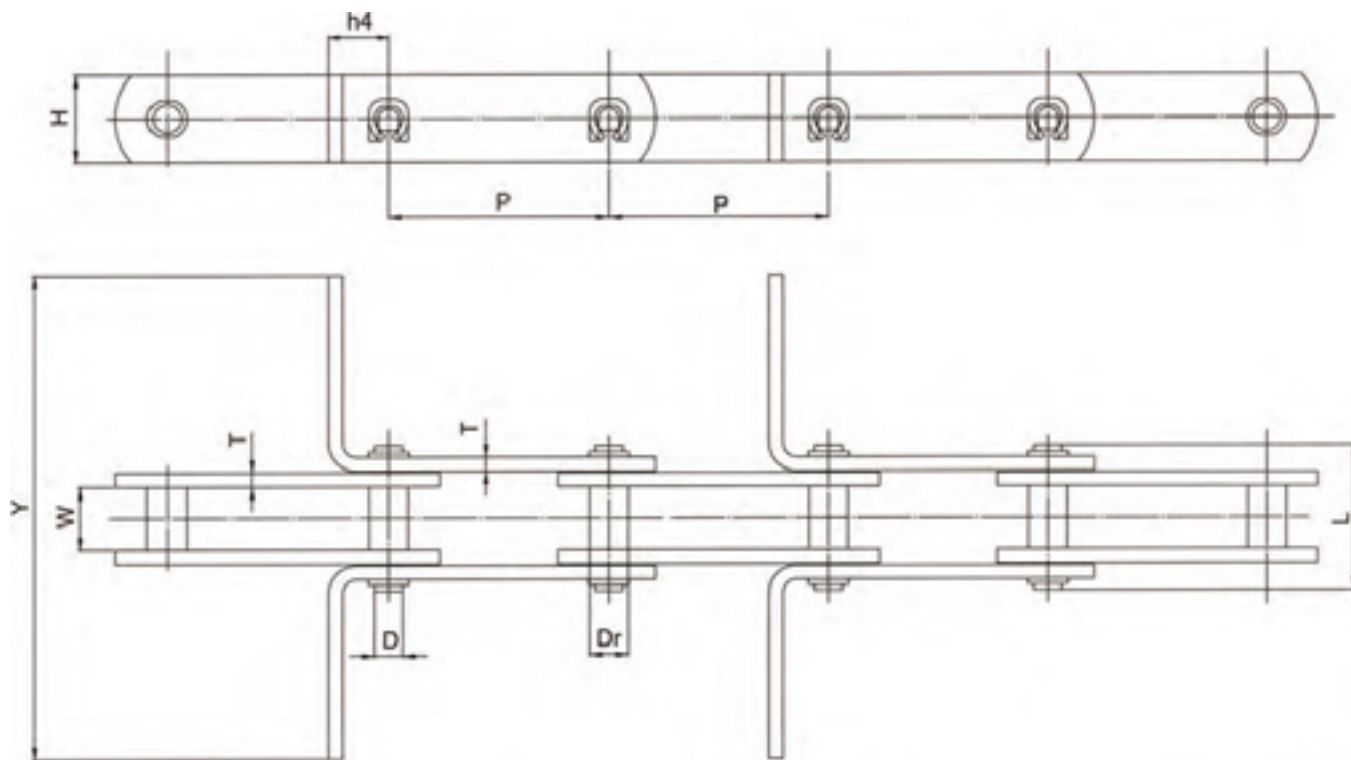

Chain No.	Pitch P mm	Bush Diameter Dr max mm	Width Between Inner Plates W min mm	Pin Diameter D max mm	Pin Length L mm	Scraper Plate Dimensions			
						H max mm	T max mm	Y max mm	h2 max mm
P802218L180	80	18.0	22.0	12.0	49.0	40.0	4.0	180	32.0
P1002520L150	100	20.0	25.0	14.0	63.0	35.0	5.0	150	26.5
P1252520L140	125	20.0	25.0	14.0	63.0	35.0	5.0	140	25.0
P1252520L180	125	20.0	25.0	14.0	63.0	35.0	5.0	180	25.0
P1253026L274	125	26.0	30.0	18.0	72.2	45.0	6.0	274	30.0
P1253026L380	125	26.0	30.0	18.0	77.5	45.0	6.0	380	30.0
P1254530L380	125	30.0	45.0	20.0	96.0	50.0	8.0	380	32.0
P1503022L290	150	22.0	30.0	16.0	69.5	50.0	6.0	290	36.0
P1503022L380	150	22.0	30.0	16.0	69.5	50.0	6.0	380	36.0
P1504530L380	150	30.0	45.0	20.0	96.0	50.0	8.0	380	36.0
P1504530L480	150	30.0	45.0	20.0	96.0	50.0	8.0	480	36.0
P1604530L290	160	30.0	45.0	20.0	96.0	50.0	8.0	290	32.0

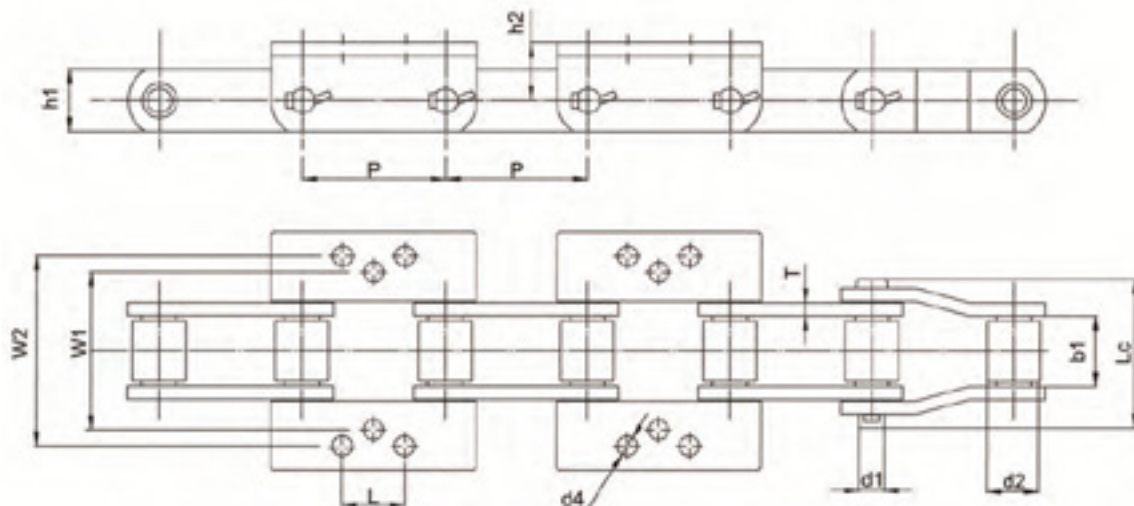

Chain No.	Pitch P mm	Width Between Inner Plates b1 mm	Roller Diameter d2 mm	Pin Diameter d1 mm	Pin Length Lc mm	Plate Depth h1 mm	Plate Thickness T mm	Attachment Dimensions				Ultimate Tensile Strength Q kN	
								h2 mm	W1 mm	W2 mm	L mm		d4 mm
P15125	101.6	50.8	41.25	19	101.8	44.5	8	38.1	119.1	134.9	44.5	11.9	195.6
US3945	101.6	50.8	31.75	15.88	99.5	38.0	7.9	34.9	120.6	134.9	44.5	11.1	167

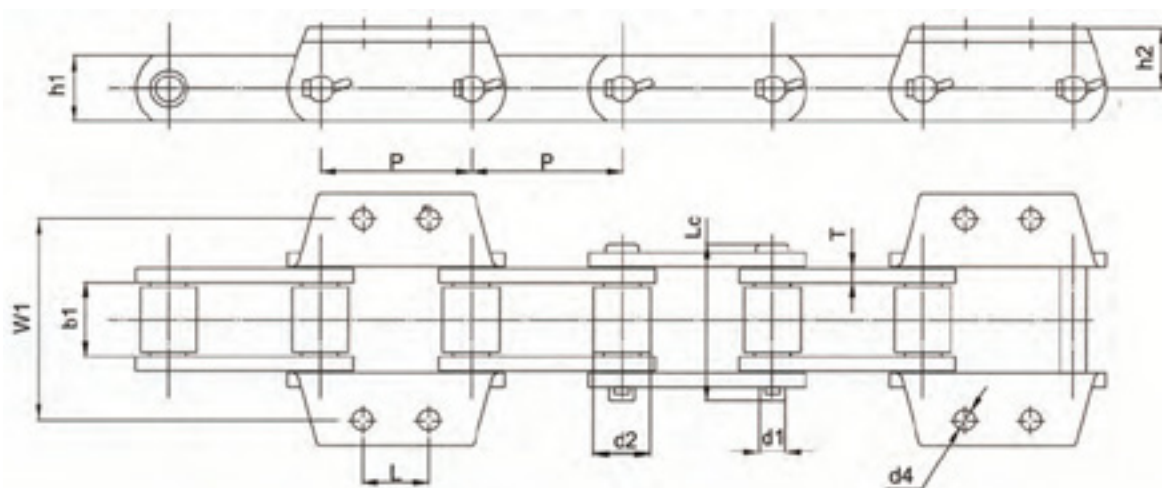

Chain No.	Pitch P mm	Width Between Inner Plates b1 mm	Roller Diameter d2 mm	Pin Diameter d1 mm	Pin Length Lc mm	Plate Depth h1 mm	Plate Thickness T mm	Attachment Dimensions				Ultimate Tensile Strength Q kN
								h2 mm	L mm	W1 mm	d4 mm	
C9856K44	152.4	76.2	69.85	25.4	152	63.5	12.7	47.7	63.5	184.2	20.6	622.3
M8R4539	78.11	38.1	31.75	15.88	87	38.1	7.9	31.8	31.8	104.6	14.3	175
MSR3433	101.6	54	37.1	15.88	110	38.1	9.5	28.5	44.5	134.8	14.3	200
US3952	101.6	50.8	36.5	19.05	109	44.5	9.5	41.3	44.5	139.7	13.5	240

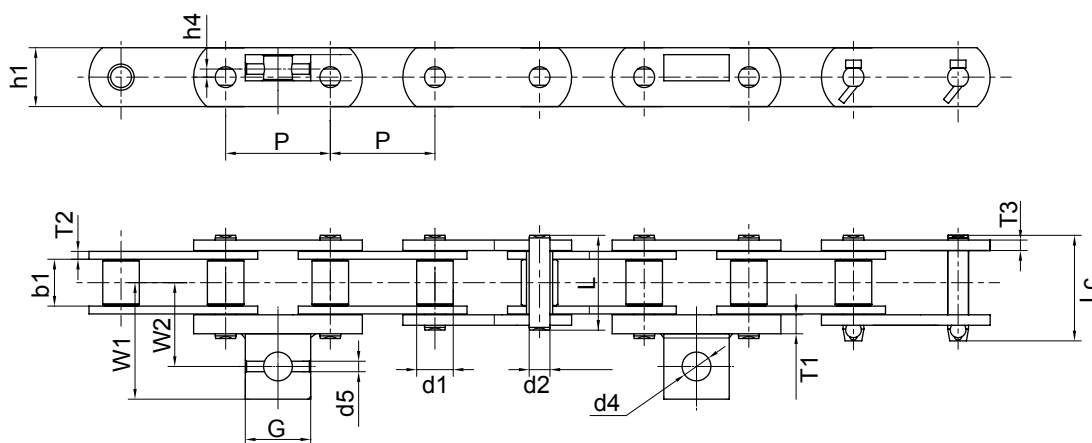

Chain No.	P mm	W2 mm	W1 mm	G mm	h4 mm	d4 mm	d5 mm	T1 kN
P80F7	80.0	56.4	81.4	50.5	5.0	21.0	8.2	6.2
P80F8	80.0	63.0	88.0	50.0	2.0	22.0	10.2	14.2
P80F17	80.0	66.3	91.3	50.0	7.5	24.0	—	15.0
P80F19	80.0	56.5	81.5	50.0	2.8	22.0	8.0	20.0
P80F21	80.0	57.0	82.0	50.0	7.0	21.5	—	15.0

Chain No.	Pitch P mm	Roller Diameter d2 max mm	Width Between Inner Plates b1 min mm	Pin Diameter d1 max mm	Pin Length		Plate Depth h1 max mm	Plate Thickness T2/T3 max mm	Ultimate Tensile Strength Q max mm	Weight Per Metre q max kN
					L max mm	Lc max mm				
P80F7	80.0	35.76	35.3	18.0	72.0	76.7	46.00	7.0/6.2	95.0	11.91
P80F8	80.0	27.94	33.8	15.9	68.4	76.0	44.45	6.0/8.0	190.0	10.80
P80F17	80.0	36.00	35.3	18.0	81.0	81.5	45.00	12.7	195.0	12.90
P80F19	80.0	27.94	33.8	15.90	68.4	75.8	45.00	6.0/8.0	190.0	11.20
P80F21	80.0	27.94	34.0	15.90	78.4	—	45.00	6.0/8.0	190.0	10.70

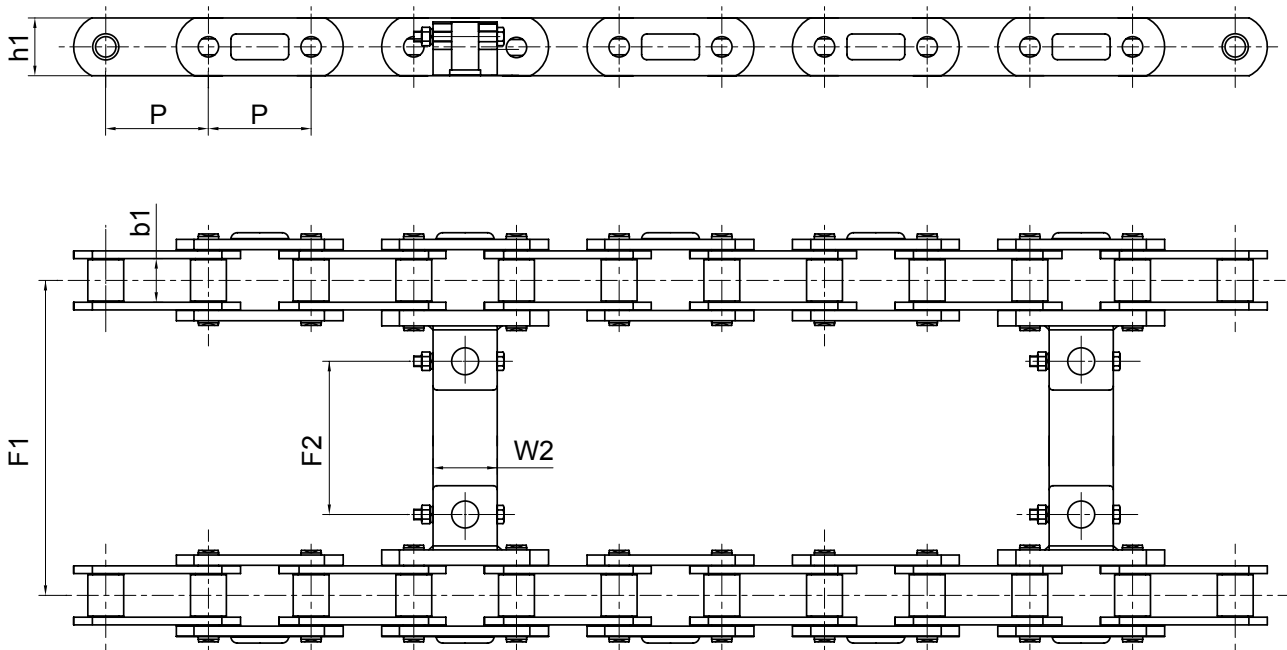

Chain No.	P mm	b1 mm	h1 mm	F1 mm	F2 mm	W2 mm
P80F8	80.0	33.8	45.0	575.0	449.0	50.0
P80F17	80.0	35.3	45.0	575.0	442.4	50.0

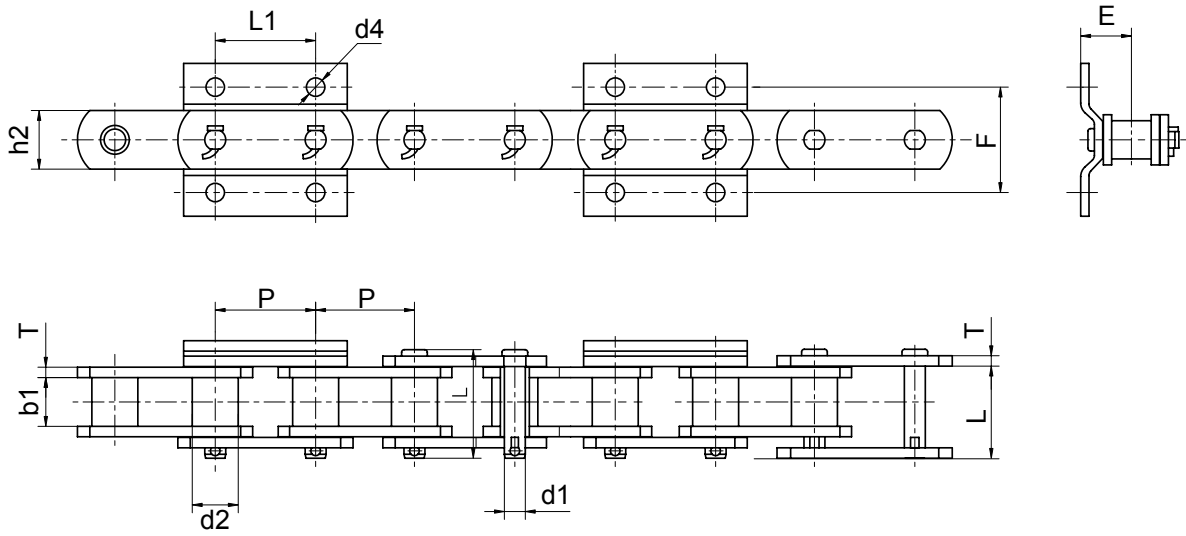

Chain No.	Pitch P mm	Roller Diameter d2 max mm	Width Between Inner Plates b1 min mm	Pin Diameter d1 mm	Pin Length L mm	Plate Depth H1 mm	Plate Thickness T mm	Attachment Dimension				Ultimate Tensile Strength Q min kN
								F mm	L1 mm	d4 mm	E mm	
P76.2F31	76.2	34.9	37.1	15.9	86.5	44.5	7.9	80	75	14	46.5	253.6
P75F18	75.0	29.0	30.0	14.5	69.0	38.1	6.3	80	75	14	38.5	204.9
P75F22	75.0	32.0	37.1	15.9	86.5	44.5	7.9	75	75	14	46.5	253.6
P75F24	75.0	29.0	30.0	14.5	69.0	38.1	6.3	80	75	14	38.5	204.9
P100F97	100.0	40.0	51.4	19.1	109.5	50.8	9.5	100	100	16	58.0	351.0
P100F127-G4	100.0	50.0	57.5	24.0	117.0	63.5	9.5	100	100	75	62.5	470.0

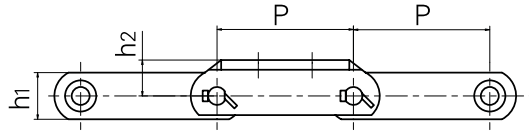

**K24**

**K3**

**K35**

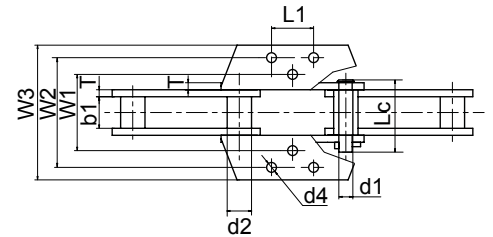
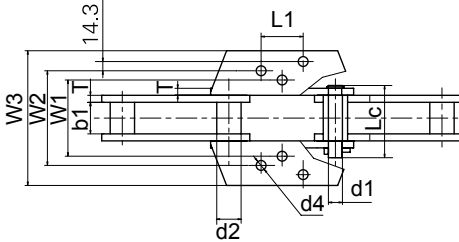
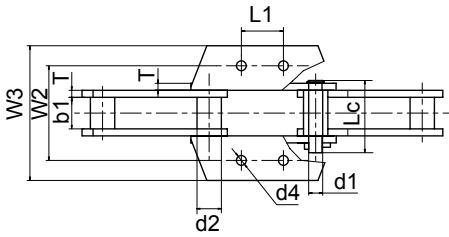

**K44**

**K443**

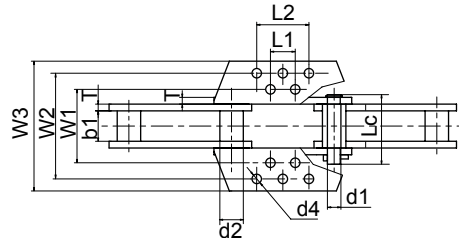
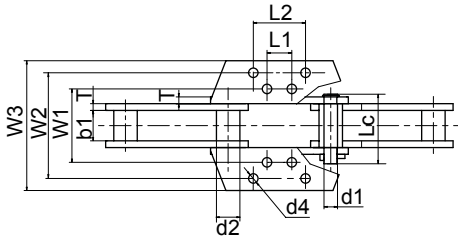

Chain No.	Pitch P mm	Roller Diameter d2 mm	Width Between Inner Plates b1 mm	Pin Diameter d1 mm	Pin Length Lc mm	Plate Depth H1 mm	Plate Thickness T mm	Average Tensile Strength Q kN	Weight Per Metre q kg/m
856	152.4	44.5	76.2	25.40	155.5	63.5	12.7	539	24.5
857	152.4	44.5	76.2	25.40	155.5	82.6	12.7	755	30.0
859	152.4	60.3	95.3	31.75	190.0	101.6	16.0	1180	51.0
864	177.8	60.3	95.3	31.75	190.0	101.6	16.0	1230	51.0

Chain No.	Attachment Dimension	Attachment Dimension								Weight Per Metre q kg/alt.	
		P mm	h2 mm	W1 mm	W2 mm	W3 mm	L1 mm	L2 mm	T mm		d4 mm
856	K24	152.4	47.6		184.2	241	63.5	—	12.7	18.0	1.5
856	K3	152.4	47.6	166.7	277.8	344	70.0	—	12.7	15.0	2.8
856	K35	152.4	47.6	184.2	298.5	344	63.5	—	12.7	18.0	2.8
859	K44	152.4	76.2	228.6	330.2	381	70.0	114.5	16.0	17.5	5.0
864	K443	177.8	76.2	228.6	330.2	381	95.3	140.0	16.0	17.5	7.5



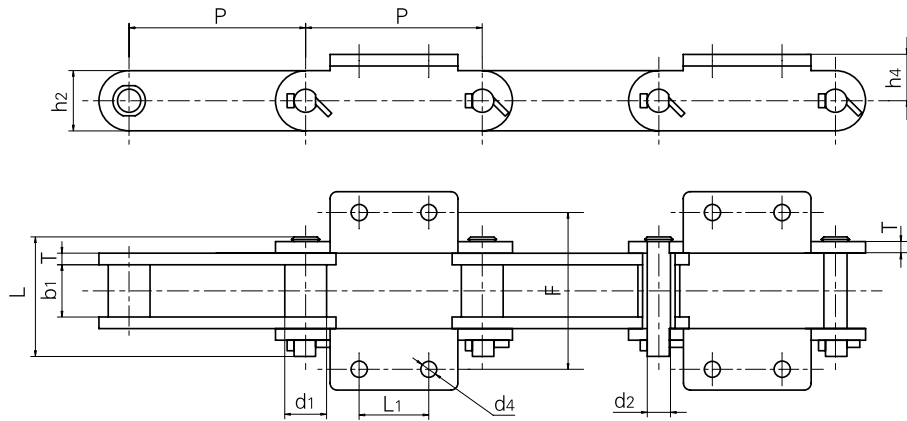

Conveyor Type	Chain No.	Pitch P mm	Roller Diameter d2 mm	Width Between Inner Plates b1 mm	Pin Diameter d1 mm	Pin Length L mm	Plate Depth h2 mm	Plate Thickness T mm	Attachment Dimension				Weight Per Metre Q min kN
									L1 mm	F mm	h4 mm	d4 mm	
DS400	P152F123	152.4	36.0	36.5	15.5	90.0	50.0	8.0	60	120	38	8.0	275
DS640	P250F44	250.0	48.5	57.6	22.2	120.0	75.0	10.0	125	160	60	10.0	560

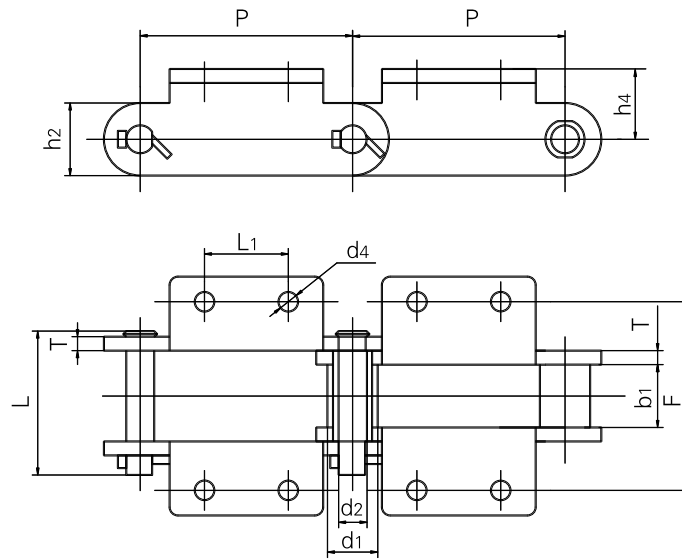

Conveyor Type	Chain No.	Pitch P mm	Roller Diameter d2 mm	Width Between Inner Plates b1 mm	Pin Diameter d1 mm	Pin Length L mm	Plate Depth h2 mm	Plate Thickness T mm	Attachment Dimension				Weight Per Metre Q min kN
									L1 mm	F mm	h4 mm	d4 mm	
SDB400	P250F45	250.0	36.0	40.0	20.0	89.0	65.0	8.0	85	130	55	14.0	450
SDB500 (540)	P250F46	250.0	36.0	44.0	21.0	94.0	85.0	8.0	85	132	55	18.5	500
SDB630 (600)	P250F47	250.0	45.0	52.0	30.0	128.0	115.0	10.0	85	162	75	18.5	1000

# Chain Handling Tools

Chain handling tools are essential for working with chains, allowing for efficient installation, maintenance, and repair.

Chain tools play a vital role in chain assembly, maintenance, and repair processes. They enable proper tensioning, customisation, and cutting of chains, ensuring their optimal performance and longevity.

It is important to use the appropriate chain tools for the specific chain type and size to ensure safe and accurate handling.



## Chain Puller

The chain puller provides a swift and efficient solution for endless chain assembly. The two hooked jaws securely grip the chain ends, whilst the user-friendly hand screw, effortlessly guides the connecting link into position for a quick and hassle-free operation.

Engineered for durability, this tool guarantees precise and controlled chain handling across a variety of industrial applications.

Model	Chain Size	kg/set
TD-CP1	35 - 60	0.23
TD-CP2	60 - 100	0.7
TD-CP3	80 - 240	1.12



## Chain Breaker

The chain breaker is a lightweight hand tool that quickly disassembles roller chains without the need for a hammer, punch or vice. In short, "one tool does all the work".

Model	Chain Size	kg/set
TD-CB1	35 - 60	0.36
TD-CB2	60 - 100	1
TD-CB3	100-140	6



## Straight Punch Type Chain Cutter

Straight punch type Chain Cutter has much higher efficiency in quick disassembling for chains compared with the conventional chain cutter.

Model	Chain Size	kg/set
No. 25	25	0.85
No. 35 - 40	35 - 40	0.85
No. 50	50	1.15
No. 60	60	1.15
No. 80	80	1.9
No. 100	100	2.5



## Roller Chain Riveting Punch

An essential tool in the assembly and maintenance of roller chains, the riveting punch secures the pins by deforming their ends, creating a rivet that holds the chain links together. The design includes a knurled handle, ensuring a secure grip for precise and effective use.

Model	Chain Size
RP-40	40
RP-50	50
RP-60	60
RP-80	80
RP-100	100
RP-100HE	100HE
RP-120HE	120HE
RP140HE	140HE
RP160HE	160HE





## Western Australia

### Chain & Drives, Wangara

Unit 1, 45 Inspiration Drive,  
Wangara, WA 6065 Australia

**P** +61 8 9303 4966

**E** [support@chainanddrives.com.au](mailto:support@chainanddrives.com.au)

### Chain & Drives, Welshpool

Unit 16, 51-53 Kewdale Road,  
Welshpool, WA 6106 Australia

**P** +61 8 6314 1155

**E** [support@chainanddrives.com.au](mailto:support@chainanddrives.com.au)

## New South Wales

### Chain & Drives, Arndell Park

Unit 7/70 Holbeche Road,  
Arndell Park, NSW 2148 Australia

**P** +61 2 9674 8611

**E** [salesnsw@chainanddrives.com.au](mailto:salesnsw@chainanddrives.com.au)

## Become a TransDrive Dealer

### Interested in becoming a TransDrive Dealer?

Get in touch:

**E** [info@transdrive.com.au](mailto:info@transdrive.com.au)

# TRANSDRIVE®

## DRIVE PERFORMANCE

Need more information about  
TransDrive products, customised  
products and services, get in touch.

[info@transdrive.com.au](mailto:info@transdrive.com.au)  
[transdrive.com.au](http://transdrive.com.au)

Supplier

