

TRANSDRIVE[®]

DRIVE PERFORMANCE



Taper Lock Bushes

transdrive.com.au

TRANSDRIVE®

DRIVE PERFORMANCE

TransDrive was established to bring together our passion and experience in power transmission by being able to offer affordable, high-quality products to the power transmission and bearing market. Built on the philosophy of improving performance and quality of all of our TransDrive products.

Transdrive products have been manufactured and tested to meet ISO standards and the tough, working conditions of heavy industries.

Our team have experience in power transmission and bearings. Every product we design and manufacture is backed by years of industry knowledge and an understanding of what our customers and the market need.

At TransDrive, our goal is simple: to provide accessible, high-quality products at affordable pricing. With an unwavering commitment to excellence, TransDrive operates with a focus on providing innovative industry solutions.

Whether it is through our custom products, the standard range of pulleys, slew drives, chains and sprockets, TransDrive is dedicated to delivering effective solutions for the trades that offer increased productivity and reliability.

Taper Lock Bushes facilitate a quick method of securing a sprocket, pulley or coupling.

We have a wide range of Taper lock bushes, used for the mechanical joining of a shaft to a sprocket or a pulley. Taper lock bushes are fastened securely to a shaft via the tapered surface. This provides flexibility between the main component to be suitable with many shaft sizes. Our range of Taper Lock Bushes complements our coupling, pulley and sprockets stock.

TransDrive range of Taper Lock Bushes come in a variety of bore sizes, in both metric and imperial in sizes from 1008 through to 6050 in both steel and stainless steel.

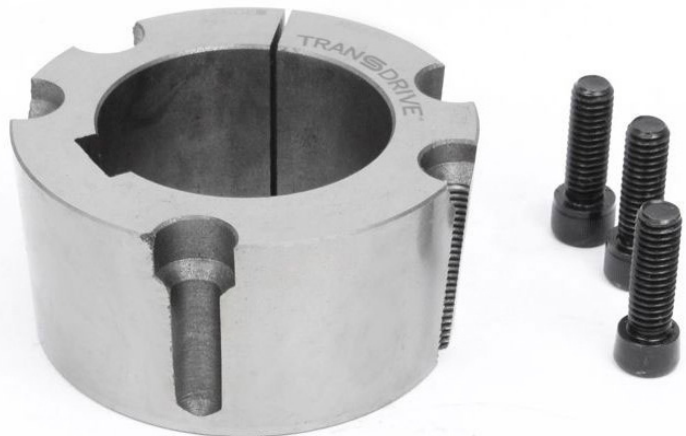

Range and material specifications

The Taper Lock Bushes are manufactured to the highest quality standards using GG22 - 25 cast iron depending on size.

Thin wall bushes are produced from C45 steel. All surfaces are carefully machined to provide maximum contact area and transmission of torque.

Contents

Taper Lock Bushes	04
Specifications	05
Bush Series - Metric	07
Bush Series - Imperial	11
Distributors	15

Taper Lock Bushes

Taper Lock Bushes facilitate a quick method of securing a sprocket, pulley or coupling.

We have a wide range of Taper lock bushes, used for the mechanical joining of a shaft to a sprocket or a pulley. Taper lock bushes are fastened securely to a shaft via the tapered surface. This provides flexibility between the main component to be suitable with many shaft sizes. Our range of Taper Lock Bushes complements our coupling, pulley and sprockets stock.

TransDrive range of Taper Lock Bushes come in a variety of bore sizes, in both metric and imperial in sizes from 1008 through to 6050 in both steel and stainless steel.

Range and material specifications

The Taper Lock Bushes are manufactured to the highest quality standards using GG22 - 25 cast iron depending on size.

Thin wall bushes are produced from C45 steel. All surfaces are carefully machined to provide maximum contact area and transmission of torque.



Specifications

Taper Bush 1008 to 3030

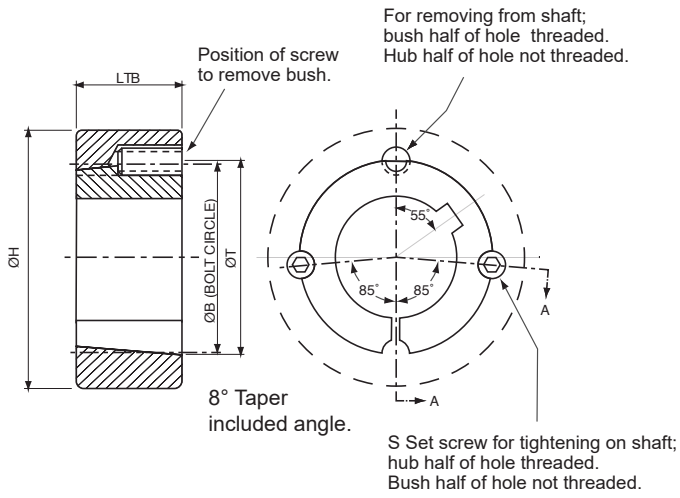

Taper Bush 3525 to 5050

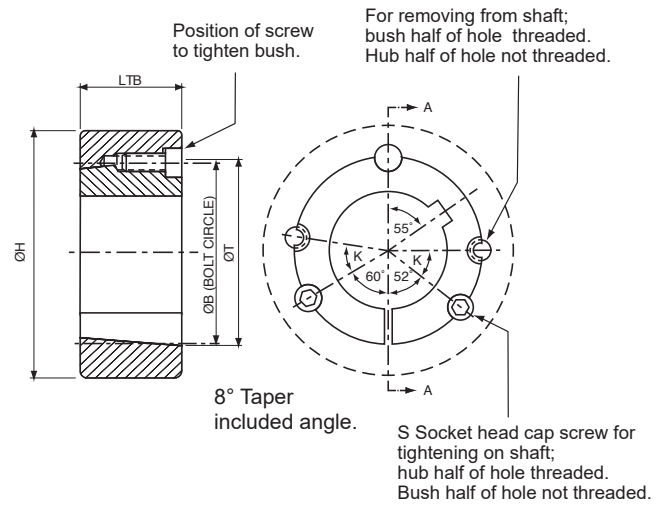

Bush Size	Ø T	LBT	Minimum HUB Dia H			Ø B	S Set Screws		K
			UTS 200 N/mm2 Gray Iron	UTS 250 N/mm2 Gray Iron	UTS 420 N/mm2 Steel		Qty. Screws	Size (Inches)	
1008	35.20	22.3	59	54	51	33.73	2	1/4 x 1/2	-
1108	38.38	22.3	61	57	54	36.92	2	1/4 x 1/2	-
1210	47.62	25.4	99	86	78	44.44	2	3/8 x 5/8	-
1215	47.62	38.1	79	73	68	44.44	2	3/8 x 5/8	-
1310	50.80	25.4	100	88	80	47.63	2	3/8 x 5/8	-
1610	57.15	25.4	102	92	85	53.97	2	3/8 x 5/8	-
1615	57.15	38.1	86	81	77	53.97	2	3/8 x 5/8	-
2012	69.85	31.8	115	106	99	66.68	2	7/16 x 7/8	-
2517	85.73	44.5	125	119	113	82.55	2	1/2 x 1	-
2525	85.73	63.5	115	111	108	82.56	2	1/2 x 1	-
3020	107.96	50.8	154	146	140	101.60	2	5/8 x 1.1/4	-
3030	107.96	76.2	141	136	132	101.60	2	5/8 x 1.1/4	-
3525	127.00	63.5	206	191	178	122.68	3	1/2 x 1.1/2	40°
3535	127.00	89.0	185	176	168	122.68	3	1/2 x 1.1/2	40°
4030	146.05	76.2	220	207	197	140.72	3	5/8 x 1.3/4	40°
4040	146.05	101.5	203	195	188	140.72	3	5/8 x 1.1/4	40°
4535	161.93	89.0	221	212	205	155.70	3	3/4 x 2	40°
4545	161.93	114.3	211	205	200	155.70	3	3/4 x 2	40°
5040	177.80	101.6	236	229	223	170.69	3	7/8 x 2.1/4	37°
5050	177.80	127.0	230	223	219	170.69	3	7/8 x 2.1/4	37°

Specifications

How to install

1. Clean shaft, bore and outside of bush, and bore of hub. Remove any oil, lacquer or dirt. Place bush in hub and match half holes to make complete holes (each complete hole will be threaded on one side only).
2. Lightly oil thread and point of set screws, or thread and under head of cap screws. Place screws loosely in holes that are threaded on hub side.
3. Make sure bush is free in hub. Slip assembly onto shaft and locate in the desired position.
4. Tighten screws alternately and evenly until all are pulled up tightly (See table for torque settings).
5. Hammer against large end of bush using hammer and block or sleeve to avoid damage. Screws can now be turned a little more to the specified torque setting. Repeat this alternate hammering and screw re-tightening until the specified torque is reached.
6. Fill all holes with grease to exclude dirt.

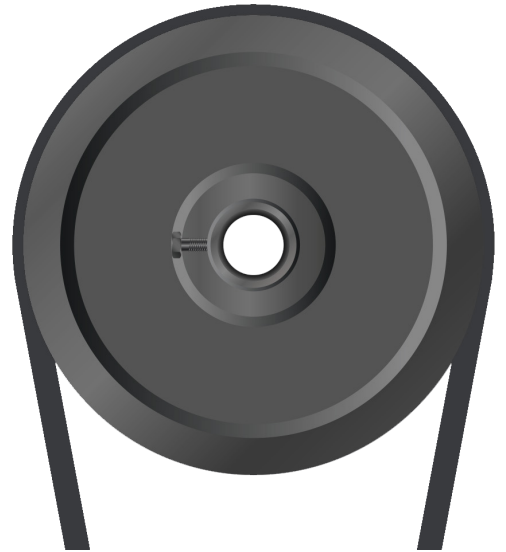

How to remove

1. Remove all screws (●). Lightly oil thread and point of set screws, or thread and under head of cap screws.
2. Insert screws into removal holes that are threaded on the bush side (☺). In sizes where washers are found under screw heads, be sure to use these washers.
3. Tighten screws alternately until bush is loosened in hub and then remove the complete assembly. If bush does not loosen immediately, tap on hub.

1008 to 3030

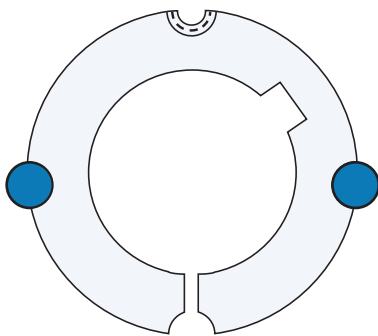

3525 to 5050

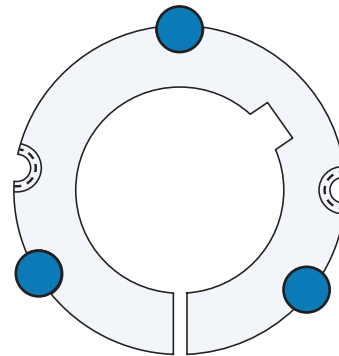

Recommended wrench torque

Bush Size	Screws	Tightening Torque (Nm)	Bush Size	Screws	Tightening Torque (Nm)	Bush Size	Screws	Tightening Torque (Nm)
1008	1/4" Set Screws	6	2012	7/16" Set Screws	30	4030	5/8" Cap Screws	170
1108	1/4" Set Screws	6	2517	1/2" Set Screws	50	4040	5/8" Cap Screws	170
1210	3/8" Set Screws	20	2525	1/2" Set Screws	50	4535	3/4" Cap Screws	190
1215	3/8" Set Screws	20	3020	5/8" Set Screws	90	4545	3/4" Cap Screws	190
1310	3/8" Set Screws	20	3030	5/8" Set Screws	90	5040	7/8" Cap Screws	270
1610	3/8" Set Screws	20	3525	1/2" Cap Screws	113	5050	7/8" Cap Screws	270
1615	3/8" Set Screws	20	3535	1/2" Cap Screws	113			

1008

Bore (mm)	Weight (kg)	Key Steel
9	0.13	3 x 3
10	0.14	
11	0.14	4 x 4
12	0.13	
14	0.13	5 x 5
16	0.12	
18	0.11	6 x 6
19	0.10	
20	0.10	
22	0.09	
24	0.09	8 x 7
25	0.08	

1108

Bore (mm)	Weight (kg)	Key Steel
9	0.16	3"x 3
10	0.15	
11	0.10	4 x 4
12	0.16	
14	0.16	5 x 5
16	0.14	
18	0.14	6 x 6
19	0.13	
20	0.13	
22	0.12	
24	0.11	8 x 7
25	0.10	
28	0.09	

1210

Bore (mm)	Weight (kg)	Key Steel
11	0.20	4 x 4
12	0.28	
14	0.28	5 x 5
16	0.27	
18	0.26	6 x 6
19	0.25	
20	0.25	
22	0.23	
24	0.22	8 x 7
25	0.21	
28	0.19	
30	0.17	10 x 8
32	0.15	

1215

Bore (mm)	Weight (kg)	Key Steel
11	0.41	4 x 4
12	0.40	
14	0.39	5 x 5
16	0.38	
18	0.37	6 x 6
19	0.36	
20	0.35	
22	0.33	
24	0.31	8 x 7
25	0.30	
28	0.27	
30	0.24	10 x 8
32	0.22	

1610

Bore (mm)	Weight (kg)	Key Steel
14	0.42	5 x 5
16	0.41	
18	0.40	6 x 6
19	0.40	
20	0.39	
22	0.38	
24	0.36	8 x 7
25	0.35	
28	0.33	
30	0.31	
32	0.29	10 x 8
35	0.26	
38	0.24	12 x 8
40	0.22	
42	0.20	

1615

Bore (mm)	Weight (kg)	Key Steel
14	0.60	5 x 5
16	0.58	
18	0.56	6 x 6
19	0.56	
20	0.54	
22	0.52	
24	0.50	8 x 7
25	0.49	
28	0.47	
30	0.44	
32	0.41	10 x 8
35	0.38	
38	0.33	12 x 8
40	0.31	
42	0.28	

2012

Bore (mm)	Weight (kg)	Key Steel
14	0.79	5 x 5
16	0.78	
18	0.77	
19	0.76	6" x 6"
20	0.76	
22	0.74	
24	0.73	
25	0.71	8" x 7"
28	0.68	
30	0.66	
32	0.64	
35	0.61	10 x 8
38	0.57	
40	0.54	12 x 8
42	0.51	
45	0.47	14 x 9
48	0.42	
50	0.37	

2517

Bore (mm)	Weight (kg)	Key Steel
16	1.75	5 x 5
18	1.71	6 x 6
19	1.66	
20	1.62	
22	1.58	
24	1.56	8 x 7
25	1.56	
28	1.50	
30	1.49	
32	1.46	10 x 8
35	1.42	
38	1.35	
40	1.31	12 x 8
42	1.26	
45	1.20	14 x 9
48	1.14	
50	1.10	
55	0.95	16 x 10
60	0.82	18 x 11
65	0.70	

2525

Bore (mm)	Weight (kg)	Key Steel
22	2.20	6 x 6
24	2.17	8 x 7
25	2.15	
28	2.09	
30	2.05	
32	2.01	10 x 8
35	1.94	
38	1.86	
40	1.80	12 x 8
42	1.74	
45	0.64	14 x 9
48	0.61	
50	0.57	
55	0.54	16 x 10
60	0.51	18 x 11

3020

Bore (mm)	Weight (kg)	Key Steel
25	2.93	8 x 7
28	2.88	
30	2.85	
32	2.84	
35	2.77	10 x 8
38	2.71	
40	2.67	
42	2.60	12 x 8
45	2.56	
48	2.47	14 x 9
50	2.20	
55	2.15	
60	2.07	18 x 11
65	1.93	
70	1.70	20 x 12
75	1.50	

3030

Bore (mm)	Weight (kg)	Key Steel
35	3.97	10 x 8
38	3.89	
40	3.80	12 x 8
42	3.65	
45	3.40	14 x 9
48	3.35	
50	3.30	
55	3.25	
60	3.20	16 x 10
65	2.95	18 x 11
70	3.67	
75	2.45	12 x 12
75	2.10	

3525

Bore (mm)	Weight (kg)	Key Steel
35	4.96	10 x 8
38	4.88	
40	4.82	12 x 8
42	4.76	
45	4.67	14 x 9
48	4.57	
50	4.50	16 x 10
55	4.31	
60	4.10	81 x 11
65	3.88	
70	3.64	20 x 12
75	3.38	
80	3.10	22 x 14
85	2.80	
90	2.49	25 x 14
95	2.20	
100	2.00	28"x 16

3535

Bore (mm)	Weight (kg)	Key Steel
35	6.20	10 x 8
38	6.50	
40	6.60	12 x 8
42	6.34	
45	6.25	14 x 9
48	6.10	
50	6.00	
55	5.77	
60	5.45	16 x 10
65	5.15	
70	4.80	18 x 11
75	4.45	
80	4.06	20 x 12
85	3.63	
90	3.50	22 x 14

4030

Bore (mm)	Weight (kg)	Key Steel
40	7.85	12 x 8
42	7.78	
45	7.66	14 x 9
48	7.54	
50	7.46	16 x 10
55	7.23	
60	6.99	18 x 11
65	6.72	
70	6.43	20 x 12
75	6.11	
80	5.78	22 x 14
85	5.42	
90	5.05	25 x 14
95	4.65	
100	4.23	28"x 16
105	4.00	
110	3.80	
115	3.60	32 x 18

4040

Bore (mm)	Weight (kg)	Key Steel
40	10.46	12 x 8
42	10	
45	0.56	14 x 9
48	0.56	
50	0.54	16 x 10
55	0.52	
60	0.50	18 x 11
65	0.49	
70	0.47	20 x 12
75	0.44	
80	0.41	22 x 14
85	0.38	
90	0.33	25 x 14
95	0.31	
100	0.28	28 x 16

4535

Bore (mm)	Weight (kg)	Key Steel
55	10.69	16 x 10
60	10.40	18 x 11
65	10.08	
70	9.74	20 x 12
75	9.38	
80	8.99	22 x 14
85	8.57	
90	8.13	25 x 14
95	7.67	
100	7.17	28 x 16
105	6.66	
110	6.12	
115	6.00	
120	5.80	32 x 18
125	5.60	

4545

Bore (mm)	Weight (kg)	Key Steel
55	13.20	8 x 7
60	12.90	18 x 11
65	12.40	
70	12.00	20 x 12
75	11.50	
80	10.90	22 x 14
85	10.50	
90	9.90	25 x 14
95	9.50	
100	8.90	28 x 16
105	8.20	
110	7.40	

5040

Bore (mm)	Weight (kg)	Key Steel
70	13.93	20 x 12
75	13.52	
80	13.07	22 x 14
85	12.60	
90	12.09	25 x 14
95	11.56	
100	11.00	28 x 16
105	10.41	
110	9.80	
115	9.15	
120	8.48	32 x 18
125	7.77	

5050

Bore (mm)	Weight (kg)	Key Steel
70	13.20	20 x 12
75	12.90	
80	12.40	22 x 14
85	12.00	
90	11.50	25 x 14
95	10.90	
100	10.50	28 x 16
105	9.90	
110	9.50	
115	8.90	
120	8.20	32 x 18
125	7.40	

1008

Bore (in)	Weight (kg)	Key Steel	
		Square	Non-Square
3/8"	0.14	1/8" x 1/8"	—
1/2"	0.13		
5/8"	0.12	3/16" x 3/16"	—
3/4"	0.11		
7/8"	0.09	1/4" x 1/4"	—
1"	0.07		
1 1/8"	0.08	5/16" x 5/16"	5/16" x 1/4"
1 1/4"			
1 3/8"		3/8" x 3/8"	3/8" x 1/4"
1 1/2"			
1 5/8"		7/16" x 7/16"	7/16" x 5/16"

1108

Bore (in)	Weight (kg)	Key Steel	
		Square	Non-Square
3/8"	0.17	1/8" x 1/8"	—
1/2"	0.16		
5/8"	0.15	3/16" x 3/16"	—
3/4"	0.14		
7/8"	0.12	1/4" x 1/4"	—
1"	0.10		
1 1/8"	0.08	5/16" x 5/16"	5/16" x 1/4"
1 1/4"			
1 3/8"		3/8" x 3/8"	3/8" x 1/4"
1 1/2"			
1 5/8"		7/16" x 7/16"	7/16" x 5/16"

1210

Bore (in)	Weight (kg)	Key Steel	
		Square	Non-Square
1/2"	0.20	1/8" x 1/8"	—
5/8"	0.28	3/16" x 3/16"	—
3/4"	0.26		
7/8"	0.24	1/4" x 1/4"	—
1"	0.21		
1 1/8"	0.10	5/16" x 5/16"	5/16" x 1/4"
1 1/4"	0.15		

1215

Bore (in)	Weight (kg)	Key Steel	
		Square	Non-Square
5/8"	0.42	3/16" x 3/16"	—
3/4"	0.30		
7/8"	0.36	1/4" x 1/4"	—
1"	0.32		
1 1/8"	0.28	5/16" x 5/16"	5/16" x 1/4"
1 1/4"	0.24		

1610

Bore (in)	Weight (kg)	Key Steel	
		Square	Non-Square
1/2"	0.46	1/8" x 1/8"	—
5/8"	0.44	3/16" x 3/16"	—
3/4"	0.42		
7/8"	0.40	1/4" x 1/4"	—
1"	0.38		
1 1/8"	0.35	5/16" x 5/16"	5/16" x 1/4"
1 1/4"	0.32		
1 3/8"	0.29	3/8" x 3/8"	3/8" x 1/4"
1 1/2"	0.25		
1 5/8"	0.21	7/16" x 7/16"	7/16" x 5/16"

1615

Bore (in)	Weight (kg)	Key Steel	
		Square	Non-Square
1/2"	0.66	1/8" x 1/8"	—
5/8"	0.64	3/16" x 3/16"	—
3/4"	0.61		
7/8"	0.58	1/4" x 1/4"	—
1"	0.55		
1 1/8"	0.51	5/16" x 5/16"	5/16" x 1/4"
1 1/4"	0.46		
1 3/8"	0.41	3/8" x 3/8"	3/8" x 1/4"
1 1/2"	0.36		
1 5/8"	0.30	7/16" x 7/16"	7/16" x 5/16"

2012

Bore (in)	Weight (kg)	Key Steel	
		Square	Non-Square
5/8"	0.85	3/16" x 3/16"	—
3/4"	0.83		
7/8"	0.80	1/4" x 1/4"	—
1"	0.77		
1 1/8"	0.74	5/16" x 5/16"	5/16" x 1/4"
1 1/4"	0.70		
1 3/8"	0.66	3/8" x 3/8"	3/8" x 1/4"
1 1/2"	0.61		
1 5/8"	0.56	7/16" x 7/16"	7/16" x 5/16"
1 3/4"	0.51		
1 7/8"	0.45	1/2" x 1/2"	1/2" x 5/16"
2"	0.39		

2517

Bore (in)	Weight (kg)	Key Steel	
		Square	Non-Square
3/4"	1.77	3/16" x 3/16"	—
7/8"	1.74	1/4" x 1/4"	—
1"	1.70		
1 1/8"	1.65	5/16" x 5/16"	5/16" x 1/4"
1 1/4"	1.60		
1 3/8"	1.54	3/8" x 3/8"	3/8" x 1/4"
1 1/2"	1.48		
1 5/8"	1.41	7/16" x 7/16"	7/16" x 5/16"
1 3/4"	1.33		
1 7/8"	1.25	1/2" x 1/2"	1/2" x 5/16"
2"	1.17		
2 1/8"	1.07	5/8" x 5/8"	5/8" x 7/16"
2 1/4"	0.98		
2 3/8"	0.88		
2 1/2"	0.77		

2525

Bore (in)	Weight (kg)	Key Steel	
		Square	Non-Square
7/8"	2.38	1/4" x 1/4"	—
1"	2.31		
1 1/8"	2.24	5/16" x 5/16"	5/16" x 1/4"
1 1/4"	2.19		
1 3/8"	1.99	3/8" x 3/8"	3/8" x 1/4"
1 1/2"	1.97		
1 5/8"	1.94	7/16" x 7/16"	7/16" x 5/16"
1 3/4"	1.62		
1 7/8"	1.72	1/2" x 1/2"	1/2" x 5/16"
2"	1.58		
2 1/8"	1.45	5/8" x 5/8"	5/8" x 7/16"
2 1/4"	1.31		
2 3/8"	1.18		
2 1/2"	1.01		

3020

Bore (in)	Weight (kg)	Key Steel	
		Square	Non-Square
1 1/4"	3.07	3/8" x 3/8"	3/8" x 1/4"
1 3/8"	3.00		
1 1/2"	2.93		
1 5/8"	2.85	7/16" x 7/16"	7/16" x 5/16"
1 3/4"	2.76		
1 7/8"	2.67	1/2" x 1/2"	1/2" x 5/16"
2"	2.57		
2 1/8"	2.47	5/8" x 5/8"	5/8" x 7/16"
2 1/4"	2.36		
2 3/8"	2.24		
2 1/2"	2.12		
2 5/8"	1.99		
2 3/4"	1.85	3/4" x 3/4"	3/4" x 1/2"
2 7/8"	1.78		
3"	1.56		

3030

Bore (in)	Weight (kg)	Key Steel	
		Square	Non-Square
1 1/4"	4.44		
1 3/8"	4.34	3/8" x 3/8"	3/8" x 1/4"
1 1/2"	4.23		
1 5/8"	4.12	7/16" x 7/16"	7/16" x 5/16"
1 3/4"	3.99		
1 7/8"	3.85	1/2" x 1/2"	1/2" x 5/16"
2"	3.70		
2 1/8"	3.55	5/8" x 5/8"	5/8" x 7/16"
2 1/4"	3.38		
2 3/8"	3.21		
2 1/2"	3.02		
2 5/8"	2.63	3/4" x 3/4"	3/4" x 1/2"
2 3/4"	2.62		
2 7/8"	2.41		
3"	2.19		

3525

Bore (in)	Weight (kg)	Key Steel	
		Square	Non-Square
1 1/2"	5.28	3/8" x 3/8"	3/8" x 1/4"
1 5/8"	5.18	7/16" x 7/16"	7/16" x 5/16"
1 3/4"	5.08		
1 7/8"	4.96	1/2" x 1/2"	1/2" x 5/16"
2"	4.84		
2 1/8"	4.71	5/8" x 5/8"	5/8" x 7/16"
2 1/4"	4.57		
2 3/8"	4.42		
2 1/2"	4.27	3/4" x 3/4"	3/4" x 1/2"
2 5/8"	4.11		
2 3/4"	3.94		
2 7/8"	3.76		
3"	3.58	7/8" x 7/8"	7/8" x 5/8"
3 1/8"	3.38		
3 1/4"	3.18		
3 3/8"	2.07		
3 1/2"	2.80	1" x 1"	1" x 3/4"
3 3/4"	2.50		
4"	2.20		

3535

Bore (in)	Weight (kg)	Key Steel	
		Square	Non-Square
1 1/2"	7.16	3/8" x 3/8"	3/8" x 1/4"
1 5/8"	7.02	7/16" x 7/16"	7/16" x 5/16"
1 3/4"	0.88		
1 7/8"	6.73	1/2" x 1/2"	1/2" x 5/16"
2"	6.55		
2 1/8"	6.36	5/8" x 5/8"	5/8" x 7/16"
2 1/4"	6.16		
2 3/8"	5.96		
2 1/2"	5.75		
2 5/8"	5.51	3/4" x 3/4"	3/4" x 1/2"
2 3/4"	5.28		
2 7/8"	5.02		
3"	4.77	7/8" x 7/8"	7/8" x 5/8"
3 1/8"	4.50		
3 1/4"	4.21		
3 3/8"	3.92		
3 1/2"	3.62		

4030

Bore (mm)	Weight (kg)	Key Steel	
		Square	Non-Square
1 3/4"	8.33	7/16" x 7/16"	7/16" x 5/16"
2"	8.04	1/2" x 1/2"	1/2" x 5/16"
2 1/8"	7.88	5/8" x 5/8"	5/8" x 7/16"
2 1/4"	7.71		
2 3/8"	7.54		
2 1/2"	7.36	3/4" x 3/4"	3/4" x 1/2"
2 5/8"	7.16		
2 3/4"	6.96		
2 7/8"	6.75	7/8" x 7/8"	7/8" x 5/8"
3"	6.53		
3 1/8"	6.28		
3 1/4"	6.05		
3 3/8"	5.80	1" x 1"	1" x 3/4"
3 1/2"	5.54		
3 3/4"	4.98		
4"	4.40	1 1/4" x 1 1/4"	1 1/4" x 7/8"
4 1/4"	4.00		
4 1/2"	3.70		

Bush Series - Imperial

4040

Bore (mm)	Weight (kg)	Key Steel	
		Square	Non-Square
1 3/4	10.92	7/16" x 7/16"	7/16" x 5/16"
1 7/8	10.61	1/2" x 1/2"	1/2" x 5/16"
2	10.42		
2 1/8	10.21	5/8" x 5/8"	5/8" x 7/16"
2 1/4	9.99		
2 3/8	9.71		
2 1/2	9.51		
2 5/8	9.15	3/4" x 3/4"	3/4" x 1/2"
2 3/4	8.97		
2 7/8	8.09		
3	8.40		
3 1/8	8.09	7/8" x 7/8"	7/8" x 1/2"
3 1/4	7.76		
3 3/8	7.43		
3 1/2	7.08		
3 3/4	6.35		
4	5.56	1" x 1"	1" x 3/4"

4535

Bore (mm)	Weight (kg)	Key Steel	
		Square	Non-Square
2 1/4	8.65	5/8" x 5/8"	5/8" x 7/16"
2 3/8	14.06		
2 1/2	9.99		
2 3/4	9.53	3/4" x 3/4"	3/4" x 1/2"
2 7/8	12.87		
3	9.02	7/8" x 7/8"	7/8" x 1/2"
3 1/8	8.75		
3 1/4	8.46		
3 3/8	8.17		
3 1/2	7.87	1" x 1"	1" x 3/4"
3 3/4	7.22		
4	6.54		
4 1/4	5.81	1 1/4" x 1 1/4"	1 1/4" x 7/8"
4 1/2	5.03		
4 3/4	4.90		

4545

Bore (mm)	Weight (kg)	Key Steel	
		Square	Non-Square
2 1/4	14.30	5/8" x 5/8"	5/8" x 7/16"
2 3/8	14.06		
2 1/2	13.80		
2 3/4	13.20	3/4" x 3/4"	3/4" x 1/2"
2 7/8	12.87		
3	12.54	7/8" x 7/8"	7/8" x 5/8"
3 1/8	8.75		
3 1/4	11.83		
3 3/8	11.46		
3 1/2	11.07	1" x 1"	1" x 3/4"
3 3/4	10.25		
4	9.37		
4 1/4	8.43	1 1/4" x 1 1/4"	1 1/4" x 7/8"
4 1/2	7.43		

5040

Bore (mm)	Weight (kg)	Key Steel	
		Square	Non-Square
2 3/4	15.12	3/4" x 3/4"	3/4" x 1/2"
2 7/8	12.50		
3	14.54		
3 1/8	14.10	7/8" x 7/8"	7/8" x 5/8"
3 1/4	13.90		
3 3/8	13.57		
3 1/2	13.22		
3 3/4	12.49	1" x 1"	1" x 3/4"
4	11.70		
4 1/4	10.87	1 1/4" x 7/8"	1 1/4" x 7/8"
4 1/2	10.40		
4 3/4	10.00		
5	9.90		

5050

Bore (mm)	Weight (kg)	Key Steel	
		Square	Non-Square
2 3/4	15.12	3/4" x 3/4"	3/4" x 1/2"
2 7/8	12.50		
3	17.80		
3 1/8	14.10	7/8" x 7/8"	7/8" x 5/8"
3 1/4	16.93		
3 1/2	15.99		
3 3/4	15.16	1" x 1"	1" x 3/4"
4	14.18		
4 1/4	13.13	1 1/4" x 7/8"	1 1/4" x 7/8"
4 1/2	12.03		
4 3/4	10.86		
5	9.03		



Western Australia

Chain & Drives, Wangara
Unit 1, 45 Inspiration Drive,
Wangara, WA 6065 Australia

P +61 8 9303 4966

E support@chainanddrives.com.au

Chain & Drives, Welshpool
Unit 16, 51-53 Kewdale Road,
Welshpool, WA 6106 Australia

P +61 8 6314 1155

E support@chainanddrives.com.au

New South Wales

Chain & Drives, Arndell Park
Unit 7/70 Holbeche Road,
Arndell Park, NSW 2148 Australia

P +61 2 9674 8611

E salesnsw@chainanddrives.com.au

Become a TransDrive Dealer

Interested in becoming a TransDrive Dealer?

Get in touch:

E info@transdrive.com.au

TRANSDRIVE[®]

DRIVE PERFORMANCE

Need more information about
TransDrive products, customised
products and services, get in touch.

info@transdrive.com.au
transdrive.com.au

Supplier

